

# Lab Jack Horizontal Surface Z-Axis Stages / High Precision Dovetail Slide, Feed Screw

## High Load Capacity

Other Information about Stages  
 Stage Selection Table P.1639, P.1640  
 New Products P.1641  
 About Standard Stages P.1642  
 Overview, Technical Information P.1643, P.1644

Feature: Suitable for Z-axis applications requiring long stroke adjustments.

### Lab Jacks

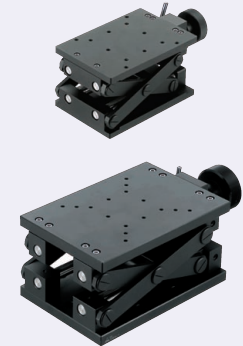

RoHS  
 Part number [ ] not RoHS compliant

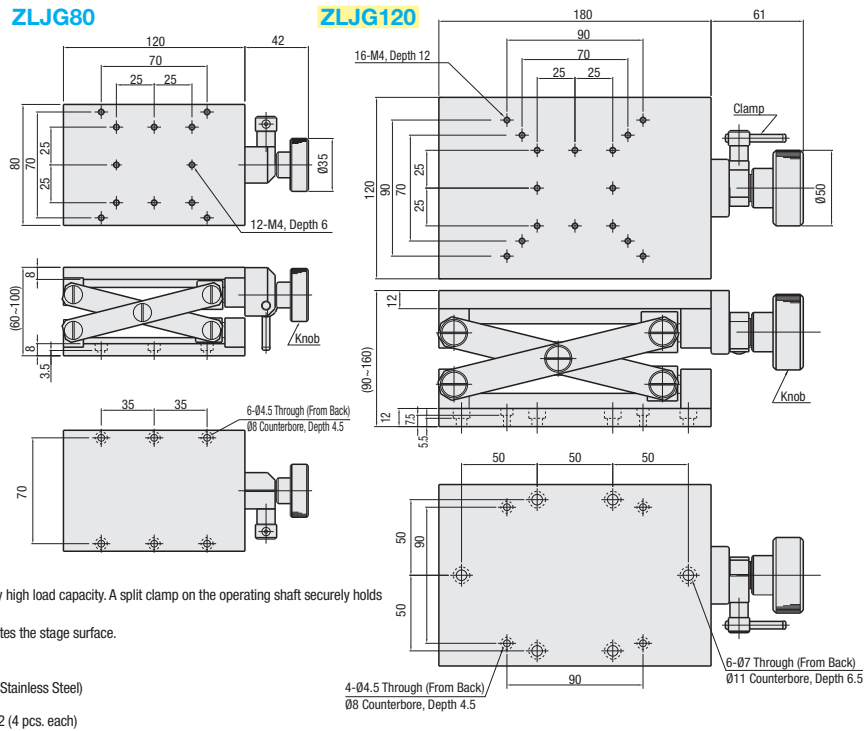

Knob operated elevating table with relatively high load capacity. A split clamp on the operating shaft securely holds the load in position.  
 Counterclockwise rotation of the knob elevates the stage surface.  
 Material: Aluminum Alloy  
 Surface Treatment: Black Anodize  
 Accessories: Hex Socket Head Cap Screw (Stainless Steel)  
 ZLJG80 : SCB4-10 (6 pcs.)  
 ZLJG120: SCB4-12, SCB6-12 (4 pcs. each)

Part Number Type	No.	Stage Surface (mm)	Travel Distance (mm)	Travel per Knob Rotation (mm)	Load Capacity (N)	Parallelism (μm)	Weight (kg)		Unit Price 1~4 pc(s).
ZLJG	80	80x120	40	2	68.6	200μm	1.25		
	120	120x180	70	3	98.0		3.50		

For orders larger than indicated quantity, please request a quotation.

Ordering Example Part Number ZLJG80 Days to Ship [Configure Online](#)

Feature: Economical XZ-Axis dovetail slide stages with 15mm thickness. Shipped orthogonally aligned to ease customer's assembly steps.

### XZ-Axis Feed Screw (Lead 0.5mm)



X-Axis P.1677  
 Z-Axis P.1707

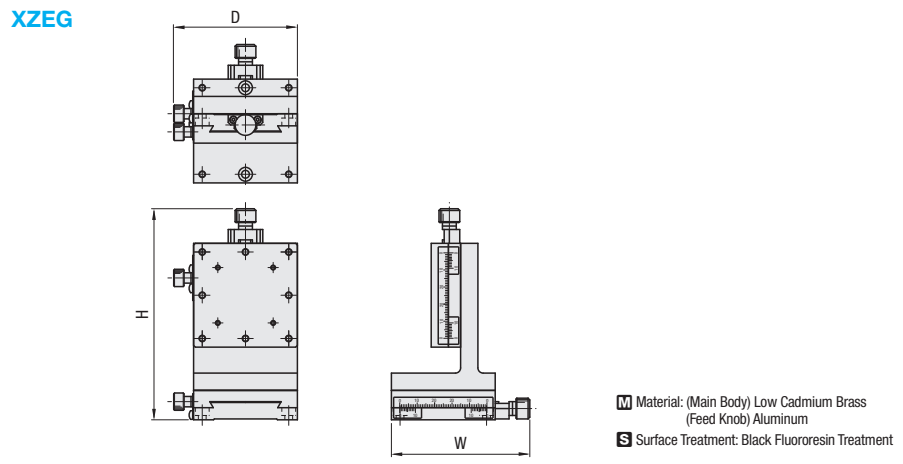

Material: (Main Body) Low Cadmium Brass (Feed Knob) Aluminum  
 Surface Treatment: Black Fluororesin Treatment

Standard Stages with Similar Specifications: Combination of XFES (P.1646) and ZFES (P.1647)

Part Number Type	No.	Stage Configuration Bottom Top	Stage Surface (mm)	External Dimension (mm)			Travel Distance (mm)		Load Capacity (N)	Weight (kg)	Accessories (4 pcs.) Type M-L	Unit Price 1~9 pc(s).
				W	D	H	X	Z				
XZEG	25	XEG25 ZEG25	25x25	45	31.7	72.5	±5	±5	9.8	0.17	SCB2-8	
	40	XEG40 ZEG40	40x40	60	46.7	95.0	±7	±7		0.46	SCB3-6	
	60	XEG60 ZEG60	60x60	80	71.8	122.0	±9	±9		1.35	SCB4-6	

For dimension details, see the CAD data and the catalog page for each stage (XEG: P.1677, ZEG: P.1707).

For orders larger than indicated quantity, please request a quotation.

Ordering Example Part Number XZEG25 Days to Ship [Configure Online](#)

# High Precision Dovetail Slide, Rack & Pinion / X: Feed Screw, Z: Rack & Pinion

Other Information about Stages  
 Stage Selection Table P.1639, P.1640  
 New Products P.1641  
 About Standard Stages P.1642  
 Overview, Technical Information P.1643, P.1644

Feature: Rapid feeding XZ-Axes stages with 18mm travel per knob rotation. Shipped orthogonally aligned to ease customer's assembly steps.

### XZ-Axis, Rack & Pinion

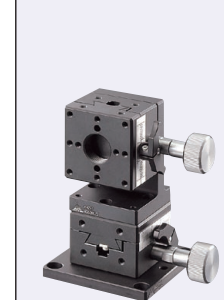

X-Axis P.1667  
 Z-Axis P.1704

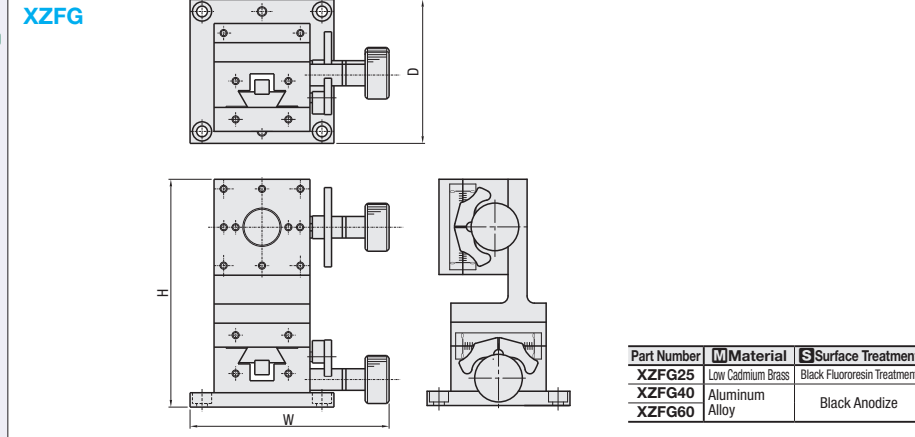

Part Number	Material	Surface Treatment
XZFG25	Low Cadmium Brass	Black Fluororesin Treatment
XZFG40	Aluminum Alloy	Black Anodize
XZFG60	Aluminum Alloy	Black Anodize

Part Number Type	No.	Stage Configuration Bottom Top	Stage Surface (mm)	External Dimension (mm)			Travel Distance (mm)		Load Capacity (N)	Weight (kg)	Accessories (4 pcs.) Type M-L	Unit Price 1~9 pc(s).
				W	D	H	X	Z				
XZFG	25	XFG25 ZFG25	25x25	40	38	55.5	±5	±5	6.9	0.20	SCB2-12	
	40	XFG40 ZFG40	40x40	83	60	95.0	±10	±10	14.7	0.45	SCB4-6	
	60	XFG60 ZFG60	60x60	106	80	105.5	±20	+20	19.6	1.25	SCB4-6	

For dimension details, see the CAD data and the catalog page for each stage (XFG: P.1667, ZFG: P.1704).

For orders larger than indicated quantity, please request a quotation.

Ordering Example Part Number XZFG25 Days to Ship [Configure Online](#)

Feature: Travel per knob rotation for X is 0.5mm, and for Z is 14/20mm. XZ stage with a fine feed X axis and a rapid feed vertical Z axis.

### Moving Horizontal Surface XZ Stages

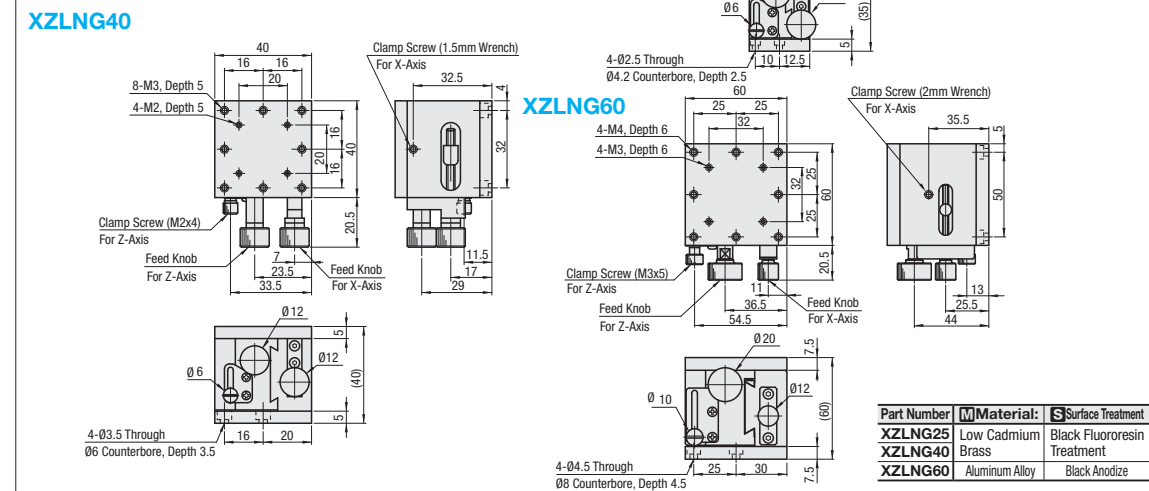
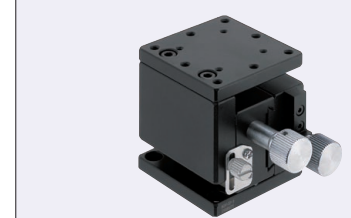

Part Number	Material	Surface Treatment
XZLNG25	Low Cadmium Brass	Black Fluororesin Treatment
XZLNG40	Aluminum Alloy	Black Anodize
XZLNG60	Aluminum Alloy	Black Anodize

Part Number Type	No.	Stage Surface (mm)	Travel Distance (mm)	Travel per Knob Rotation (mm)	Load Capacity (N)	Travel Accuracy Straightness	Weight (kg)	Accessories (4 pcs.) Type M-L	Unit Price 1~9 pc(s).
40	40x40	X:±7, Z:±10	X:0.5 Z:±14			0.51	SCB3-6		
60	60x60	X:±10, Z:±26	X:0.5 Z:±20			0.62	SCB4-8		

No graduated scale on XZLNG.

For orders larger than indicated quantity, please request a quotation.

Ordering Example Part Number XZLNG60 Days to Ship [Configure Online](#)