

Inductive Ring Sensor





F2LP-W

Ring Sensing Head for Detecting Moving Minute Metallic Objects

- Detects moving metallic objects of any shape anywhere in the ring.
- Sensor Heads with 10-mm to 100-mm diameters available.
- Incorporates a 40-ms OFF-delay timer.
- Amplifier Unit with DIN-track mounting hooks available.

Ordering Information

■ Sensor Heads

Sensor Head (non-shielded)	Min. object size	Model
10 dia. 	0.3 dia. x 0.5 mm steel rod	F2LP-W10M
20 dia. 	0.3 dia. x 1.0 mm steel rod	F2LP-W20M
50 dia. 	2.0-dia. steel ball	F2LP-W50M
75 dia. 	2.5-dia. steel ball	F2LP-W75M
100 dia. 	3.0-dia. steel ball	F2LP-W100M

■ Amplifier Unit

Power supply	Output	Model
120/240 VAC, 50/60 Hz	Relay: SPDT, 2 A, 250 VAC or 3 A, 30 VDC DC Solid-state: Photocoupler 100 mA max.	F2LP-WK4-US

Application Examples

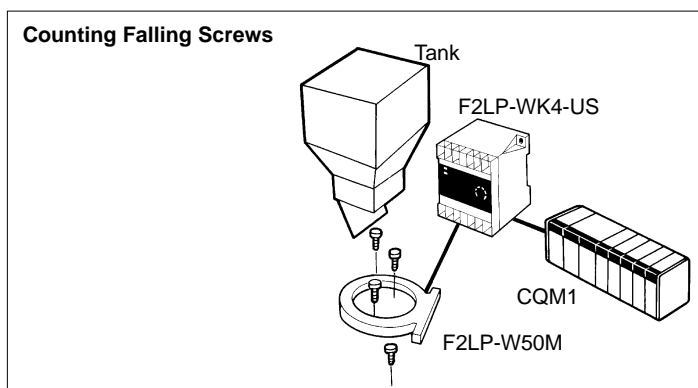

Specifications

■ Ratings/Characteristics

Sensor Units

Model	F2LP-W10M	F2LP-W20M	F2LP-W50M	F2LP-75M	F2LP-W100M
Sensing area	10 dia.	20 dia.	50 dia.	75 dia.	100 dia.
Sensing objects (see note 1)	Ferrous or non-ferrous moving metal object (Sensitivity lowers with non-ferrous metals).				
Min. object size	0.3 dia. x 0.5 mm steel rod	0.3 dia. x 1.0 mm steel rod	2.0-dia. steel ball	2.5-dia. steel ball	3.0-dia. steel ball
Ambient temperature	Operating: -25°C to 70°C (with no icing)				
Ambient humidity	Operating: 35% to 95%				
Insulation resistance	50 MΩ min.	Head case and shield (0 V) are electrically connected.			
Dielectric strength	1,000 VAC for 1 min.	Head case and shield (0 V) are electrically connected.			
Vibration resistance	Durability: 10 to 55 Hz, 1.5 mm double amplitude for 2 hours each in X, Y, Z directions				
Shock resistance	Durability: 500 m/s ² (approx. 50G) for 3 times each in X, Y, Z directions				
Cable (see note 2)	3 m (high-frequency coaxial cable)				
Weight	Approx. 80 g	Approx. 220 g	Approx. 430 g	Approx. 800 g	Approx. 1,200 g
Enclosure rating	IEC IP67				
Material	Case	Heat-resisting ABS resin	Aluminum diecast		
	Sensing surface	Heat-resisting ABS resin			

Note: 1. The moving speed is based on the natural fall of objects from a height 10 cm above the Sensor.

2. The cable can be shortened or connected to another cable, as long as the total length of the cable is from 1.5 to 10 m. Use the following cables for extension: F2LP-W10M, F2LP-W20M: Electrostatic capacity 97 nF/km; characteristic impedance 50±2 Ω
F2LP-W-50M, F2LP-W75M, F2LP-W100M: Electrostatic capacity 100 nF/km; characteristic impedance 50±2 Ω

Amplifier Unit

Supply voltage		120/240 VAC ±15%, 50/60 Hz
Power consumption		3 VA max.
Sensitivity adjustment		Selector and variable resistor
Timer	DC solid-state	Normal or 40-ms OFF delay. (selectable)
	Relay	One-shot, 40 ms (fixed)
Sensing interval	DC solid-state	Normal: 75 ms max.; OFF-delay: 125 ms max. (Minimum sensing objects can be detected at intervals specified. Larger objects need longer intervals.)
	Relay	75 ms max. (See note for DC solid-state sensing interval.)
Control output	DC solid-state	100 mA, 40 VDC max. photocoupler output; residual voltage: 2 V max. (Refer to <i>Engineering Data</i> .)
	Relay	Resistive load of 2 A at 250 VAC or 3 A at 30 VDC
Compatibility with Sensor Heads with different diameters		Can be connected to F2LP-Wj M Sensors with a diameter of 10, 20, 50, 75, or 100 (switchable).
Compensation for cord length		Switch setting
Output form		NO or NC (switchable)
Indicators		Power and operation
Ambient temperature		Operating: -10°C to 55°C (with no icing)
Ambient humidity		Operating: 35% to 85%
Insulation resistance		50 MΩ min. (at 500 VDC) between all live terminals and non-current carrying bare metal parts, and between all primary terminals (for power supply) and all secondary terminals (for non-contact output and Sensor)
Dielectric strength		1,500 VAC, 50/60 Hz for 1 minute between all live terminals and non-current carrying bare metal parts, between all primary terminals (for power supply) and all secondary terminals (for non-contact output and Sensor), and among all contact output terminals
Vibration resistance		Destruction: 10 to 55 Hz, 1.5 mm double amplitude for 2 hours in X, Y, Z directions respectively
Shock resistance		Destruction: 100 m/s ² (approx. 10G) for 3 times in X, Y, Z directions respectively
Enclosure ratings		IEC IP30
Weight		Approx. 300 g

Engineering Data

Object Size vs. Falling Speed of Object (Typ.)

F2LP-W10M

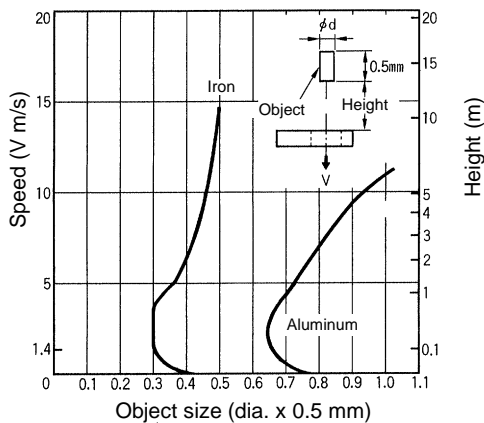

F2LP-W20M

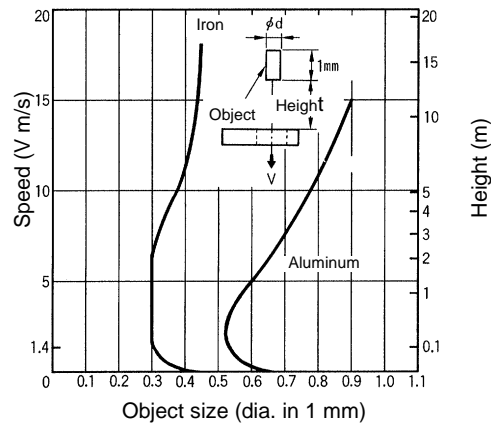

F2LP-W50M

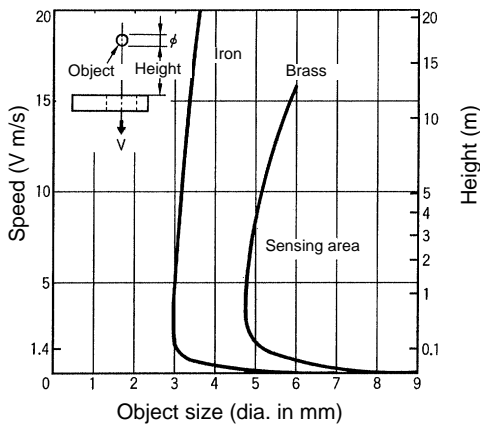

F2LP-W75M

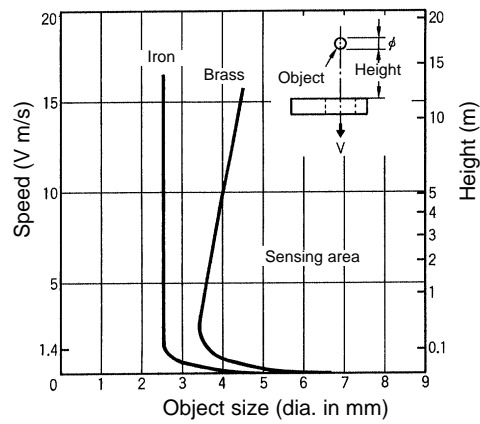

Residual Load Voltage Characteristics (Typ.)

F2LP-W100M

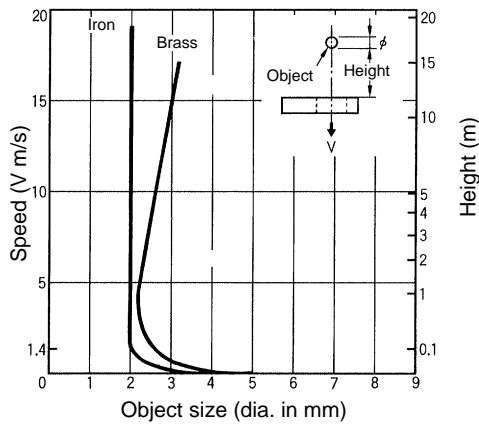

F2LP-WK4-US

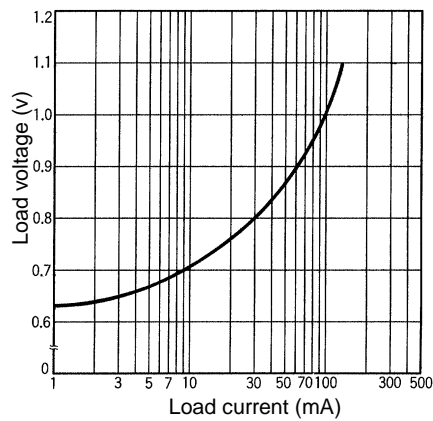

Operation

■ Amplifier Unit

- POWER indicator:**
Lit when power is on.
- OPERATION indicator:**
Lit when sensing objects.
- Sensitivity selector**
- Timer mode selector** (see note 1)
- Output mode selector** (see note 2)
- Frequency selector:**
If induction or other mutual interference is experienced when using more than one Sensor, set the Sensor to different frequencies.

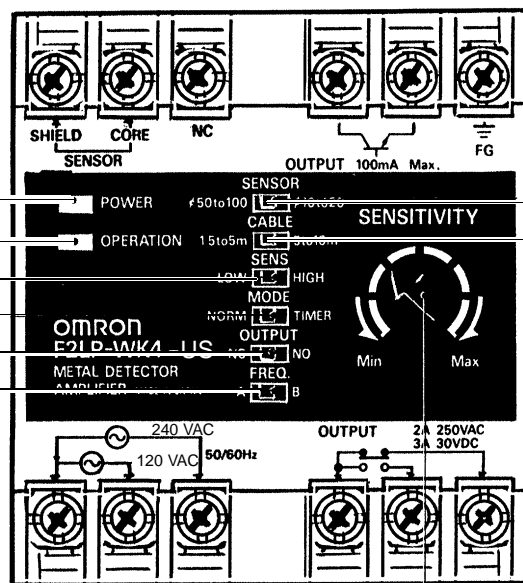

Sensor selector:
F2LP-W100M, F2LP-W20M: Select dia. of 10 to 20
F2LP-W50M, F2LP-W75M, F2LP-W100M: Select dia. of 50 to 100

Compensation selector: Select the position according to the cable length. When cutting or extending the cable, the length should be between 1.5 m and 10 m.

- Note:**
1. Timer mode selector: NORM: No timer; TIMER: OFF-delay transistor output (40 ms)
 2. Output mode selector: NO: Both transistor output and relay output ON when sensing objects; NC: Transistor output OFF and relay output ON when sensing objects

Sensitivity adjustor

■ Timing Chart

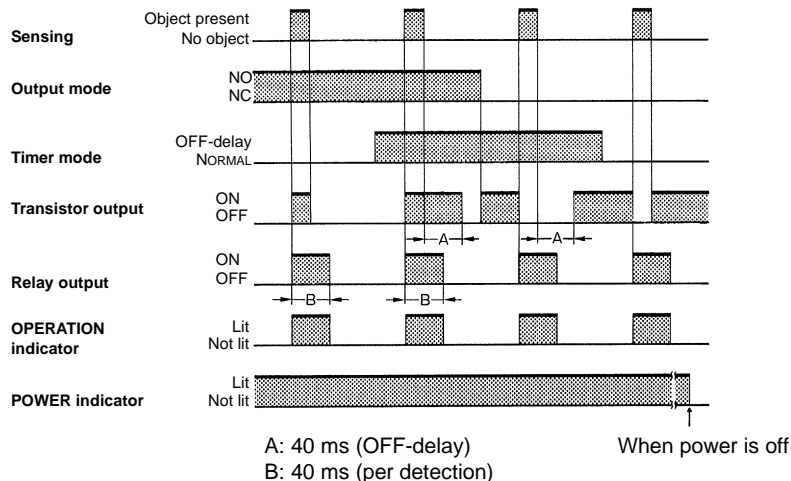

- Note:**
1. Relay outputs are ON when objects are sensed (when objects pass through the Sensor head)
 2. Each relay output is ON for 40 ms minimum regardless of the position of the timer mode selector.

Dimensions

Note: All units are in millimeters unless otherwise indicated.

Sensor Heads

F2LP-W10M

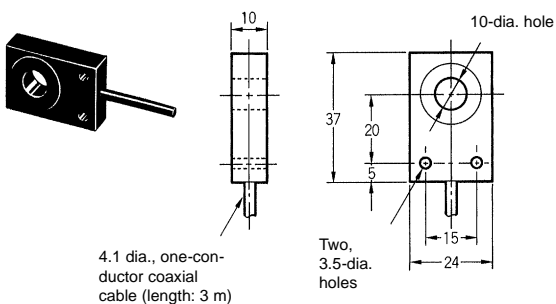

F2LP-W20M

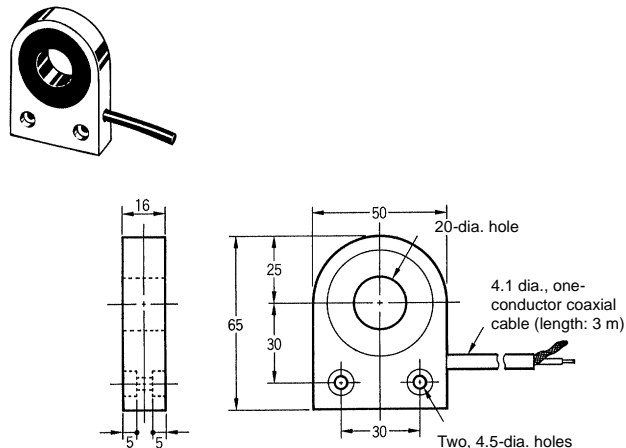

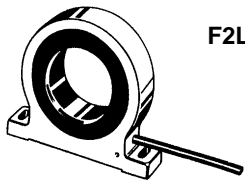

F2LP-W50M

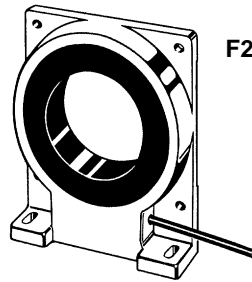
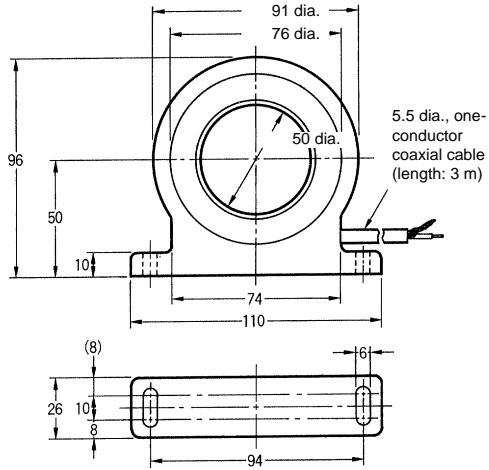

F2LP-W75M

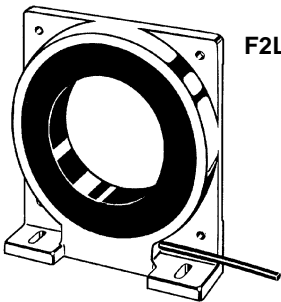
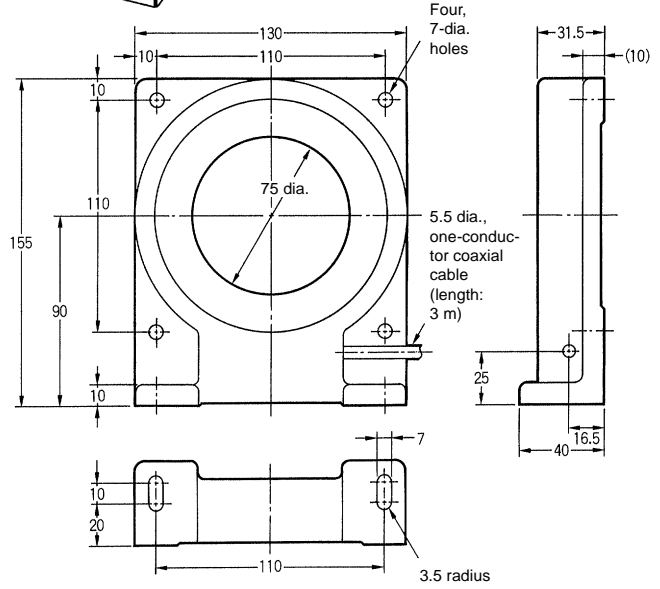

F2LP-W100M

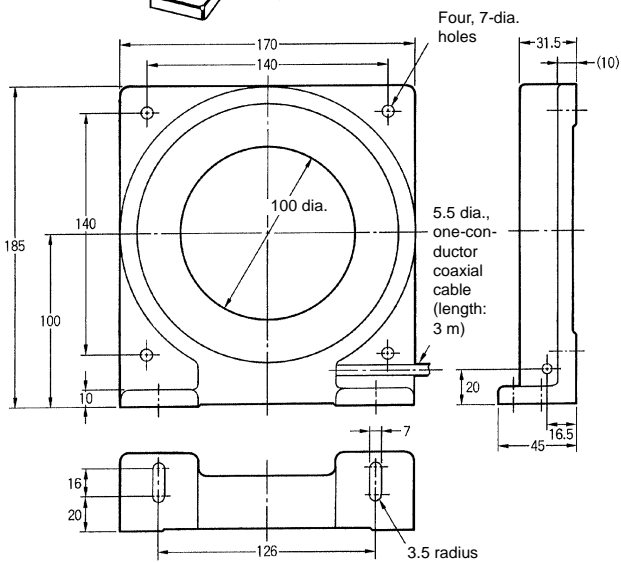

**Amplifier Unit
F2LP-WK4-US**

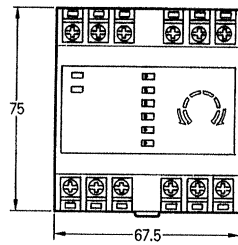
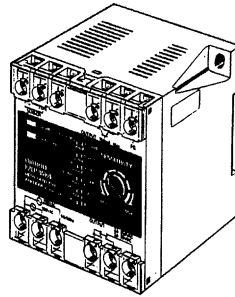

Mounting Holes

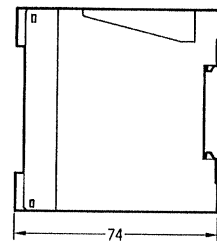
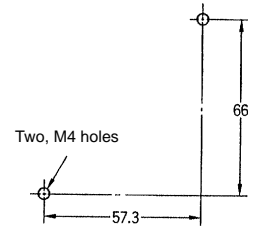

■ DC Solid State Output Stage Circuit Diagram

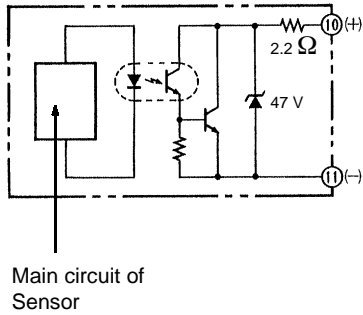

Note: 1. The load can be connected as follows:

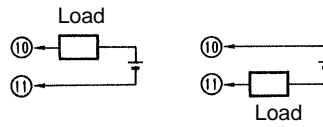

2. The maximum capacity of the load is 100 mA, 40 VDC.

■ Connections

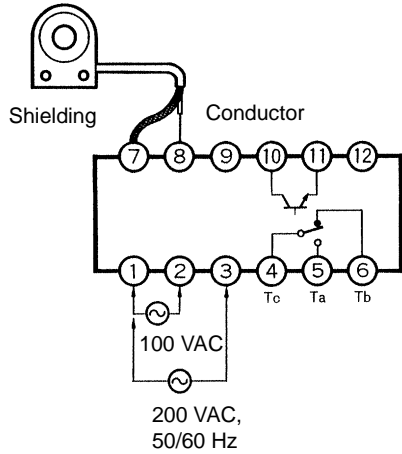

Note: Terminal 7 (internal circuit 0 V) can be grounded by grounding the Sensor, because this terminal is connected to the metal case of the Sensor. Sensor input terminals 7 and 8, transistor output terminals 10 and 11, power supply terminals 1, 2, and 3, and relay connecting terminals 4, 5, and 6 are insulated from one another.

Precautions

Please read the following carefully to ensure effective and proper use of the F2LP-W.

Influence of Metals at Close Range

- The Sensor can malfunction if there is a moving metal object around the Sensor. Keep metal objects away from the Sensor by at least the distances indicated in the following drawing and table.

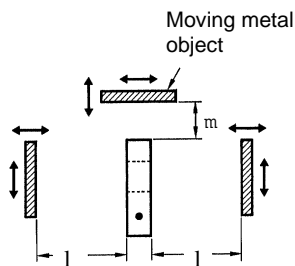

Model	Distance l	Distance m
F2LP-W10M	100	100
F2LP-W20M	100	20
F2LP-W50M	150	30
F2LP-W75M	200	40
F2LP-W100M	300	50

- The Sensor mounted on a metal base can malfunction if there is a metal object close to the coil of the Sensor. Keep metal away from the coil by at least the distances indicated in the following drawings.

F2LP-W10M

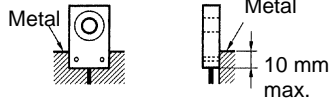

F2LP-W20M

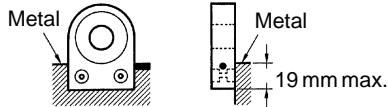

F2LP-W50M

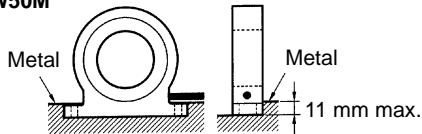

F2LP-W75M

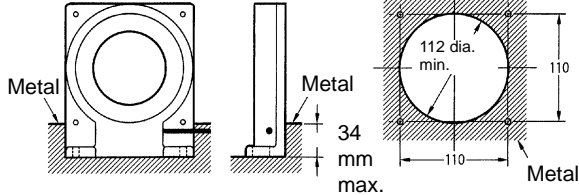

Note: To mount the F2LP-W75M on a flange, open a hole of at least 112 dia. min.

F2LP-W100M

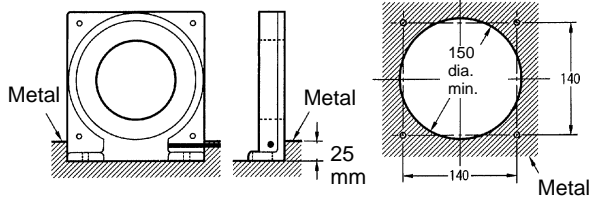

Note: To mount the F2LP-W100M on a flange, open a hole of at least 150 dia.

Mutual Interference

- When using more than one Sensor, ground the ground terminals of the Sensors and then separate the Sensors one another by at least the distances indicated in the following drawings. The distances in parentheses apply when the Sensors are set to different frequencies.

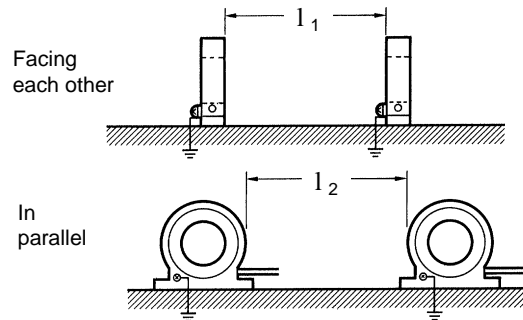

Model	Facing (l_1)	Parallel (l_2)
F2LP-W10M	500 (100)	500 (100)
F2LP-W20M	500 (100)	500 (100)
F2LP-W50M	500 (100)	500 (100)
F2LP-W75M	750 (150)	750 (150)
F2LP-W100M	1,000 (200)	1,000 (200)

Others

- Do not use the Sensor immediately after power is on, since the Sensor needs an interval of 1 to 2 seconds after power is on to function normally and sense objects.
- To maintain noise resistance when connecting a Sensor cable to the Amplifier Unit terminals, always use a cable with a conductor thickness of no more than 10 mm.

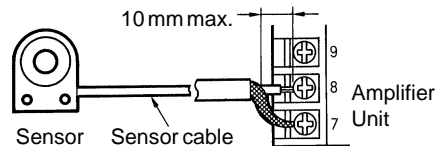

- Only one pulse (40 ms) will be output when the sensing object is stationary or if the sensing object is always present such as the case when line breakage is detected.
- When using the Sensor at a high level of sensitivity, be careful not to touch or come in contact with the Sensor because any contact with the sensing surface will be detected.

ALL DIMENSIONS SHOWN ARE IN MILLIMETERS.
To convert millimeters into inches, multiply by 0.03937. To convert grams into ounces, multiply by 0.03527.

Cat. No. D032-E1-2 In the interest of product improvement, specifications are subject to change without notice.

OMRON Corporation

Systems Components Division H.Q.
28th Fl., Crystal Tower Bldg.
1-2-27, Shiromi, Chuo-ku,
Osaka 540 Japan
Phone: 06-949-6012 Fax: 06-949-6021

Printed in Japan
0997-0.5M (0590) a