



# Operator's Handbook

Pathfinder® 6057  
Printer



Each product and program carries a respective written warranty, the only warranty on which the customer can rely. Avery Dennison Corp. reserves the right to make changes in the product, the programs, and their availability at any time and without notice. Although Avery Dennison Corp. has made every effort to provide complete and accurate information in this manual, Avery Dennison Corp. shall not be liable for any omissions or inaccuracies. Any update will be incorporated in a later edition of this manual.

©2011 Avery Dennison Corp. All rights reserved. No part of this publication may be reproduced, transmitted, stored in a retrieval system, or translated into any language in any form by any means, without the prior written permission of Avery Dennison.

### **Trademarks**

Avery Dennison®, Pathfinder®, 9462, and 9465 are registered trademarks of Avery Dennison Corporation.

Microsoft and Windows are trademarks of Microsoft Corporation.

Avery Dennison  
170 Monarch Lane  
Miamisburg, OH 45342

LITHIUM - ION RECHARGEABLE BATTERY.  
FOR PROPER RECYCLING OR DISPOSAL, CALL  
YOUR LOCAL SERVICE OFFICE.



Li-Ion

Outside the U.S., send batteries to:  
EMEA, 4 Awberry Court  
Croxley Business Park, Hatters

# TABLE OF CONTENTS

<b>INTRODUCTION</b> .....	<b>1-1</b>
Using this Manual.....	1-2
Audience .....	1-2
Getting Started .....	1-2
Helpful Reminders .....	1-2
<b>USING BATTERIES</b> .....	<b>2-1</b>
Using the Main Battery .....	2-1
Charging the Main Battery .....	2-1
Replacing the Main Battery .....	2-1
Checking the Battery Status .....	2-2
Main Battery Safety Information.....	2-3
<b>USING SUPPLIES</b> .....	<b>3-1</b>
Loading Supplies.....	3-1
Loading for Non-Peel Mode.....	3-3
Loading for Peel Mode.....	3-3
Calibrating the Supply .....	3-5
<b>ENTERING &amp; PRINTING DATA</b> .....	<b>4-1</b>
Using the Display .....	4-1
Reading the Task Bar .....	4-1
Power Management .....	4-1
Adjusting the Display Backlight.....	4-2
Printing .....	4-2
Using the Input Panel .....	4-3
Scanning Bar Codes .....	4-4
Certification Note .....	4-4
<b>CONFIGURING THE PRINTER</b> .....	<b>4-1</b>
Selecting the Supply Type.....	4-1
Adjusting the Print Contrast.....	4-2
Adjusting the Print Position .....	4-3
Supply Position.....	4-3
Print Margin .....	4-3
Overfeed Distance .....	4-3
Max Supply Length.....	4-3

**CARE & MAINTENANCE** ..... 5-1

- Cleaning ..... 5-1
  - Cleaning the Display Screen ..... 5-1
  - Cleaning the Printhead ..... 5-1
  - Cleaning the Platen, Liner Drive, and Pinch Rollers ..... 5-2
  - Cleaning the Black Mark Sensor ..... 5-3
  - Cleaning the Scanner Window ..... 5-3
  - Clearing Supply Jams ..... 5-4
- Storing the Printer ..... 5-4

**TROUBLESHOOTING** ..... 6-5

- Checking the Software Version ..... 6-5
- Printing a Test Label ..... 6-6
- Error Codes ..... 6-7
- Technical Support ..... 6-7

**SPECIFICATIONS & ACCESSORIES** ..... A-1

- Specifications ..... A-1
- Accessories ..... A-1

# INTRODUCTION

1

The Pathfinder® 6057 prints, scans bar codes, collects data, and communicates with other devices. The printer operates on a Microsoft® Windows-based CE platform.

The printer features

- ◆ Touch screen display
- ◆ Adjustable supply width capabilities
- ◆ Clock/Calendar
- ◆ USB 2.0 port communications
- ◆ Graphic printing capabilities
- ◆ LED display backlight
- ◆ Low power shutdown to conserve the battery
- ◆ On-Demand (factory-installed option) and continuous printing
- ◆ Laser scanner (factory-installed option)
- ◆ 2D laser scanner (factory-installed option)
- ◆ Wireless 802.11b/g Radio (factory-installed option)
- ◆ Wavelink Avalanche(factory-installed option)



## Using this Manual

---

Following is a summary of the contents of this manual:

	Chapter	Contents
1	Introduction	Information you should know before using the printer.
2	Using Batteries	Charging, changing, and using batteries safely.
3	Using Supplies	Supply loading.
4	Entering and Printing Data	Using the display, keypad, scanner, and printing.
5	Care & Maintenance	Clearing supply jams and cleaning the printer.
6	Troubleshooting	Common problems and solutions.
A	Specifications & Accessories	Printer specifications and accessories/options.

## Audience

---

This manual is for the operator who scans or manually enters data and prints and applies labels.

## Getting Started

---

To start using the printer, you must:

1. Review the safety information in the *Regulatory Compliance* document provided with your printer.
2. Charge the main battery. See “Charging the Main Battery” in Chapter 2 for more information.  
**Note:** You *must* charge the battery before using it.
3. Insert the main battery. See “Changing the Main Battery” in Chapter 2 for more information.
4. Load supplies in the printer. See “Loading the Supplies” in Chapter 3 for more information.
5. Turn on the printer.

**Note:** Your System Administrator must load an application in the printer before you can use it.

## Helpful Reminders

---

- ◆ Always start with a fully charged battery.
- ◆ When you load a new roll of supplies, check the main battery’s printing power, if it is low, switch to a fully charged battery (doing so ensures optimum print quality).
- ◆ Turn off the printer when you are not using it.
- ◆ Do not pound the printer when applying labels printed in peel mode.
- ◆ Operate and store the printer with the recommended temperature and humidity ranges. See Appendix A, “Specifications and Accessories,” for more information.

The printer uses two batteries; a main battery and a backup battery.

Battery	Use
Main	Running the printer. It is rechargeable using one of the chargers listed in Appendix A, "Specifications & Accessories."
Backup	Maintaining the printer's system settings. Charges from the main battery. Not user replaceable.

## Using the Main Battery

The printer's main power source is a 7.4V lithium-ion battery. To order a replacement battery, see Appendix A, "Specifications & Accessories" for more information.

**Note:** The printer uses *only* this battery; **do not** substitute batteries.

You must charge the battery when you receive the printer, even if you do not use it right away.

## Charging the Main Battery

To charge the main battery, use one of the Monarch® chargers listed in Appendix A, "Specifications & Accessories." Refer to the documentation provided with the chargers for more information. Charging time is approximately 1 – 3 hours.

**Warning:** The battery must be charged using *only* the chargers listed in this manual; the battery might explode if placed on a different charger.

## Replacing the Main Battery

To change the main battery:

1. Hold the printer upright with one hand and press the battery release button on the handle with your other hand.



2. The battery compartment door opens slightly. Use your finger to open the door.

3. Remove the battery.

4. Insert a new battery (label side up) into the compartment (connector end last).

5. Close the compartment door until it clicks into place.

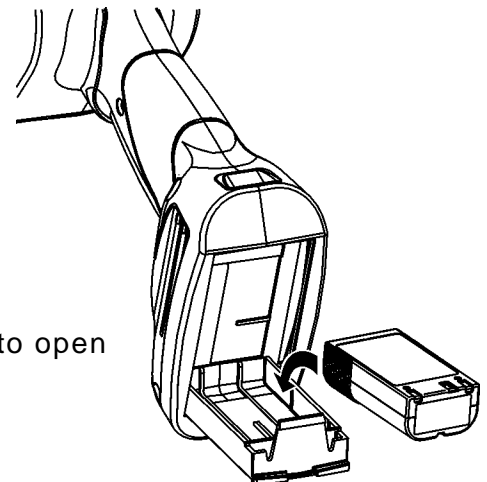

## Checking the Battery Status

The printer easily provides the status of the main and backup batteries.

1. Turn on the printer.

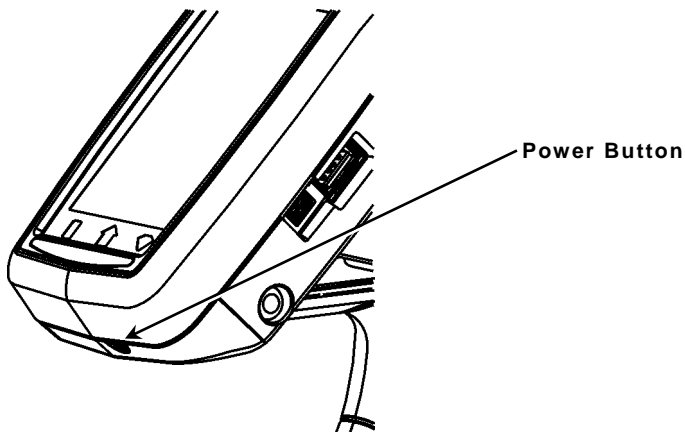

2. Touch the **Home** key.
3. Touch the battery icon (  ).

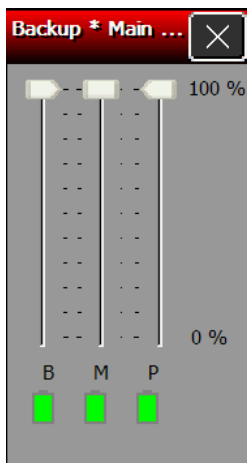

Power Supply	Description
Backup Battery	Shows the status of the backup battery. If you replace the main battery, its charge depletes while charging the backup battery. You cannot replace the backup battery.
Main Battery	Shows the status of the main battery. If the status is low, printing may be interrupted. Replace the main battery in the printer with a fully charged battery.
Printing	Shows the power levels of the main battery for system operations and printing. If the printing power level is low, you may still be able to use Windows functions, but you do not have enough battery power to print. Replace the main battery in the printer with a fully charged battery.

4. Touch the **X** to close the battery status window.



## Main Battery Safety Information

---

To order a replacement battery, see Appendix A, “Specifications & Accessories” for more information.

- ◆ You must charge the battery before using it. For optimal battery life, charge the battery within three months of receipt.

**Warning:** The battery must be charged using *only* the chargers listed in this manual; the battery might explode if placed on a different charger. See Appendix A, “Specifications and Accessories,” for more information.

- ◆ Take the battery out of the printer when storing the printer for a month or longer.
- ◆ The optimal battery storage temperature is 50°F to 73°F (10°C to 23°C), with a maximum of 104°F (40°C). The battery may permanently lose its charge capacity if stored at temperatures less than 32°F (0°C) or greater than 104°F (40°C). For longest life, the battery should be stored in a cool, dry place.
- ◆ The operating temperature for the battery is the same as for the printer. See Appendix A, “Specifications and Accessories,” for more information.
- ◆ The recommended charging temperature is 68°F to 77°F (20°C to 25°C)
- ◆ Recycle Information – Do not throw in the trash. Recycle according to your local regulations. The Rechargeable Battery Recycling Corporation (RBRC®) is a non-profit organization created to promote recycling of rechargeable batteries. For more information about how to recycle batteries in your area, visit [www.rbrc.org](http://www.rbrc.org). Batteries can also be returned postage-paid to:

Avery Dennison ERC  
200 Monarch Lane  
Door #39  
Miamisburg, OH 45342

**Warning:** **Do not** disassemble, short-circuit, heat above 80°C, or incinerate the battery; it may explode.

- ◆ **Do not** let the battery come into contact with metal objects.
- ◆ **Do not** use a battery with a cracked case.
- ◆ **Do not** get the battery wet.
- ◆ It is normal for battery capacity to decrease up to 20% over the first 300 cycles of use.
- ◆ The battery should be charged before long-term storage or after the battery has been exhausted from a printing session. Frequent charging actually prolongs battery life and has no negative effects such as memory loss.
- ◆ The printer uses battery power even when it is not printing. Charge the battery using *only* the chargers listed in this manual; the battery might explode if placed on a different charger. See Appendix A, “Specifications and Accessories,” for more information.
- ◆ Many factors affect your battery’s performance, including the quantity of labels printed, percentage of black per label, and power management.



The printer uses two types of supplies:

- ◆ Labels
- ◆ Tags

There are two print modes. The way you load the supplies depends on the print mode you use.

- ◆ *Peel mode* removes the backing paper from the supplies as it prints the labels. This mode allows you to apply the label immediately. It is only for labels. When using the on-demand sensor, you can press the trigger to print a label or the next label prints automatically when the previous one is removed.
- ◆ *Non-Peel mode* does not remove the backing paper. It is for tags and labels printed in a continuous strip.

## Loading Supplies

---

To load supplies:

1. Turn on the printer.

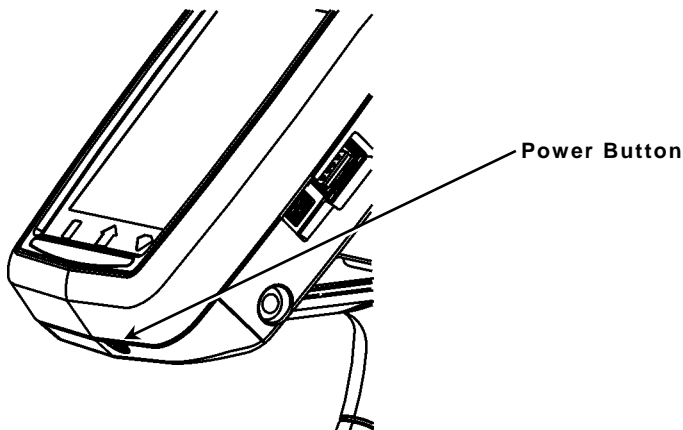

2. Press the latch buttons and open the supply cover.

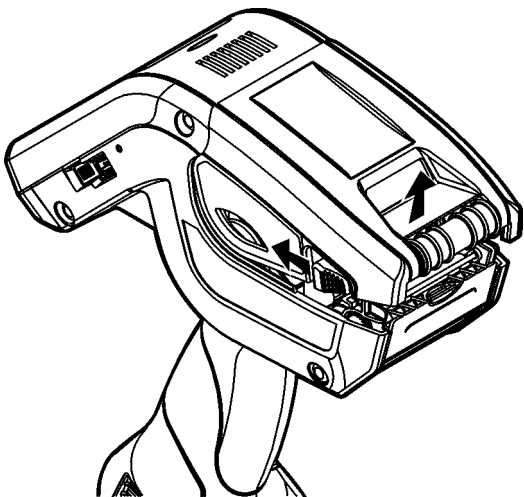

3. Spread the supply holder tabs apart with one hand so it adjusts to the size of your supply roll.
4. Press the supply lock tab all the way down (towards the inside of the printer) to lock the supply holder at 1.2". Adjust it to the middle position to lock the supply holder at 1.5". Adjust it all the way up (towards the opening of the printer) to lock the supply holder at 2.0"

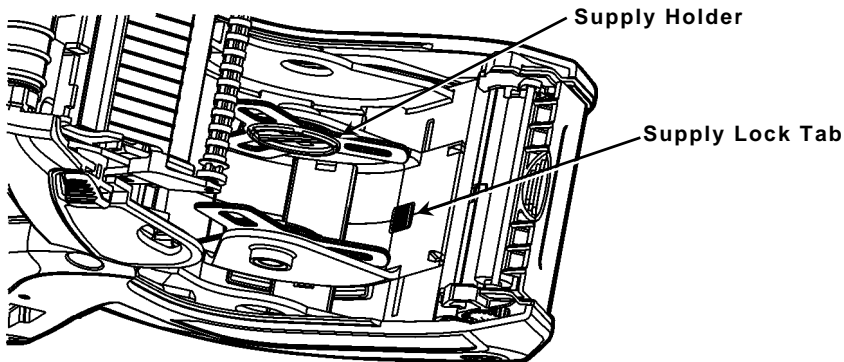

5. Place the supply roll in the supply holder so the supply feeds from the bottom.

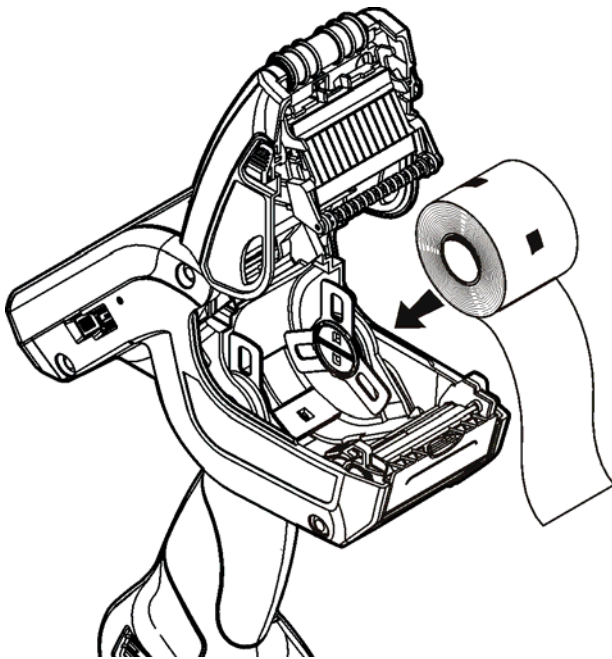

6. Continue loading supply for the printing mode you want (peel or non-peel).

## Loading for Non-Peel Mode

1. Feed the supply **over** the platen roller, peel bar, and label deflector.

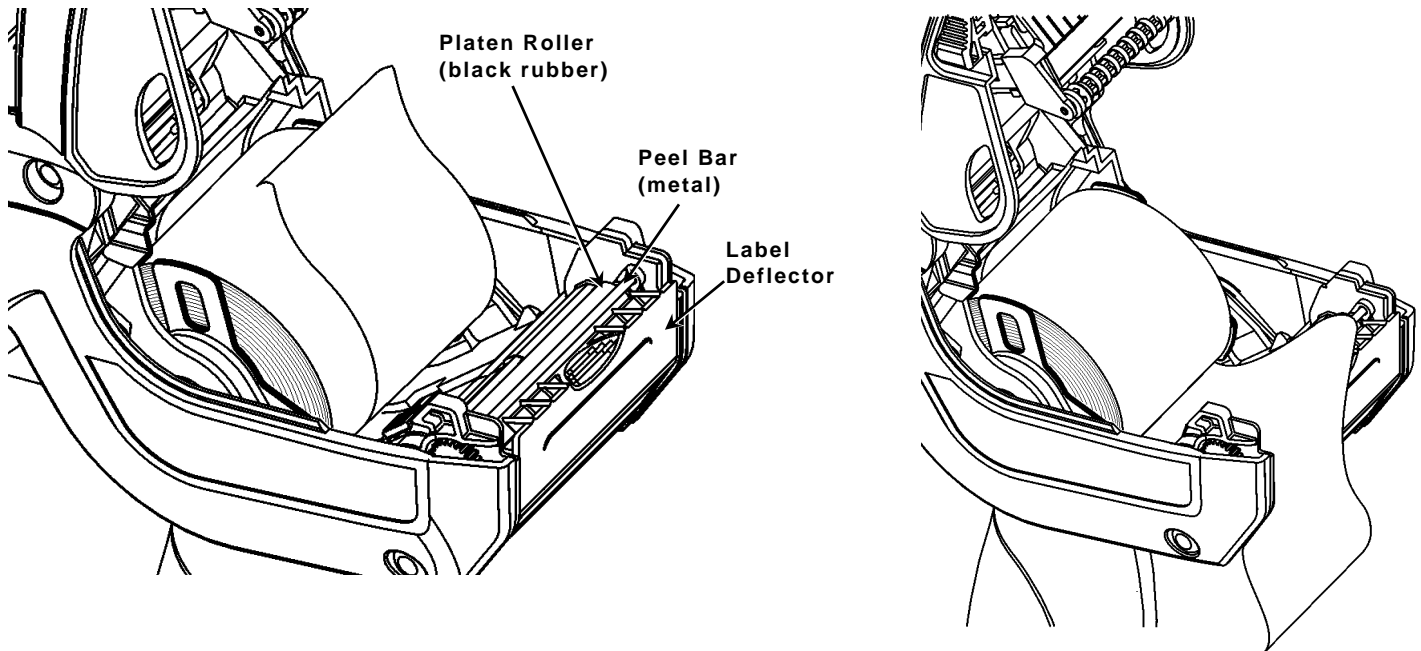

2. Close the supply cover.
3. Calibrate the supply. See "Calibrating the Supply" for more information.

## Loading for Peel Mode

1. Peel and discard the first four inches of labels from the backing paper.
2. Hold the printer upright and gently push down on the label deflector.
3. Feed the backing paper **over** the peel bar and through the slot at the base of the label deflector.

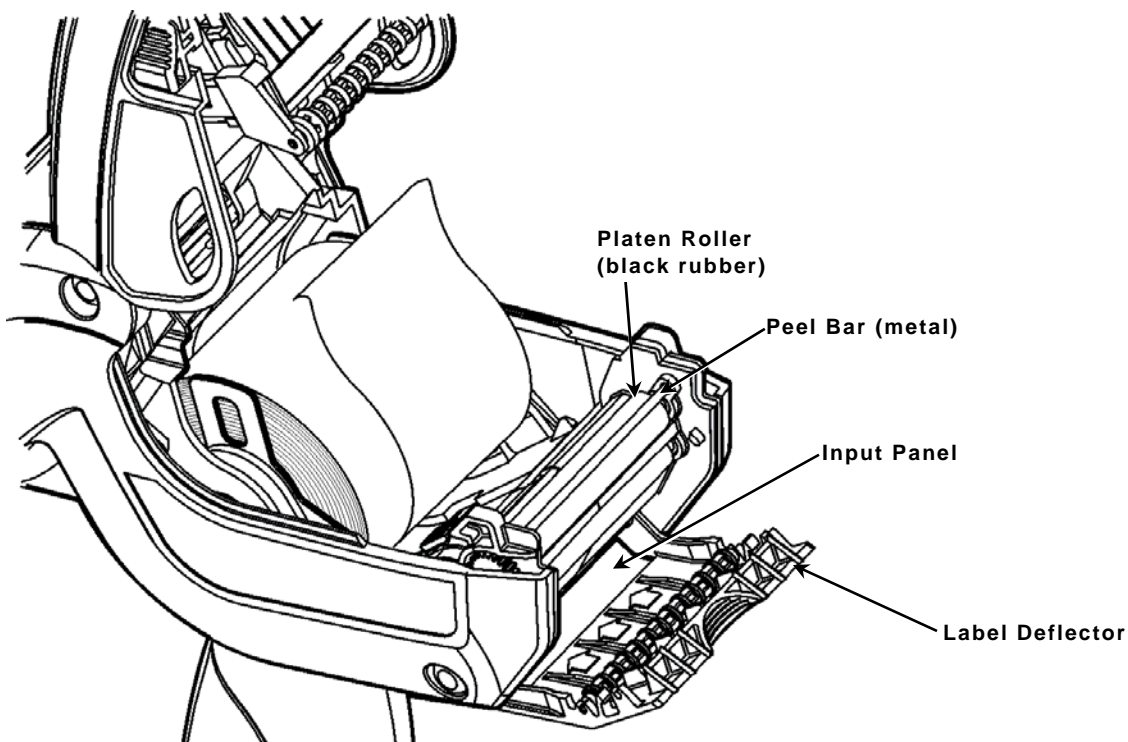

**4.** Close the supply cover.

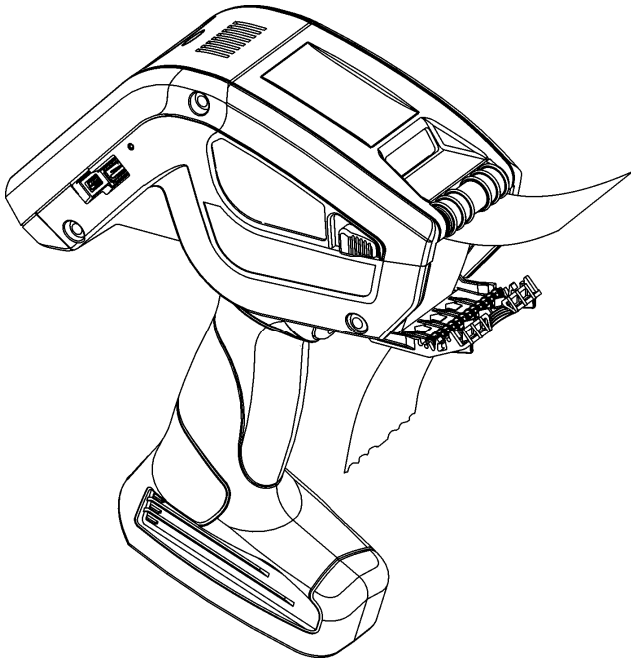

**5.** Hold the backing paper and push up the label deflector until it snaps into place.

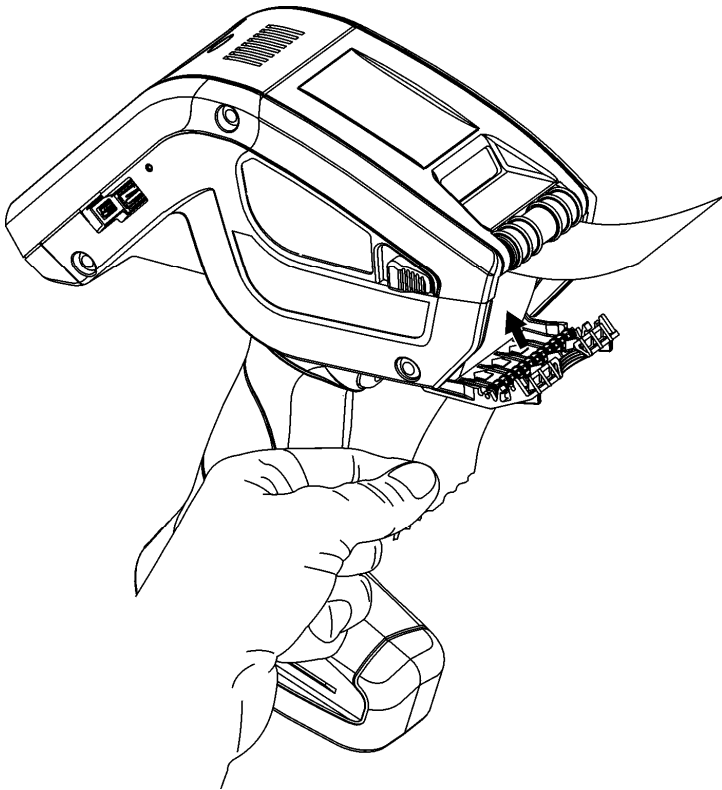

**6.** Calibrate the supply. See “Calibrating the Supply” for more information.

## Calibrating the Supply

To calibrate the supply:

1. Turn on the printer.
2. Touch the **Home** key.

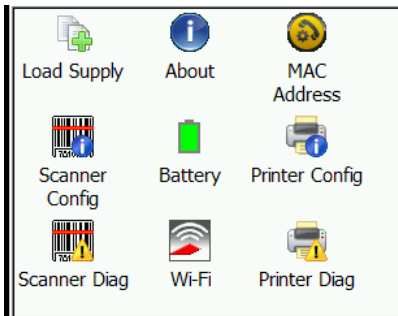

3. Select Load Supply.
4. Select **Calibrate Stock**. A label or two feeds while the supply is calibrated.



Home







This chapter explains the printer's features and how to use them.

## Using the Display



The printer has a touch screen display similar to a hand held computer. Touch the screen to select the option you want.

**Note:** Use **only your finger** on the screen. Pens and other items can cause damage. Use distilled water and a soft cloth to clean the screen; **do not use household cleaners.**

**To Open the Start Menu, touch the Emerald key.**

### Reading the Task Bar

The Task Bar has the following indicators:

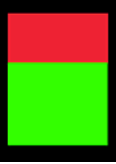
Icon	Description
	Wired/Wireless Connection
	Wireless Signal Strength
	Battery Status

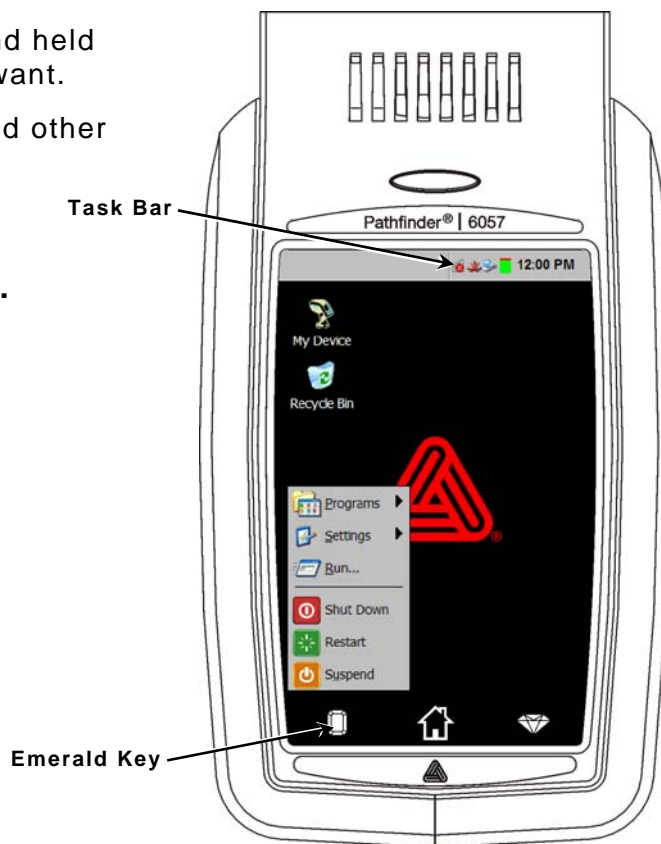

## Power Management

The printer's display automatically dims and shuts off after a specified amount of idle time. The printer "wakes up" when you touch the display or press the trigger. Touching the display only wakes the printer; you must touch it again to perform an action. Pressing the trigger wakes the printer and activates the scanner. Your System Administrator can adjust these settings.

## Adjusting the Display Backlight

---

1. Touch the Emerald key to access the Start Menu, select **Settings**, **Control Panel**, and **Backlight**.
2. Touch the > key to increase the amount of backlight or the < key to decrease the amount of backlight for each of the options

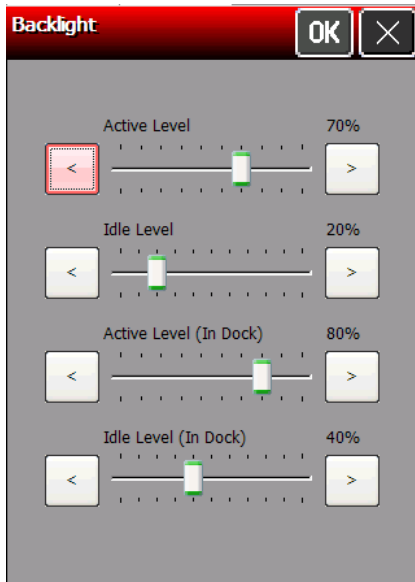

- ◆ Active level is the amount of backlight on the display when it is in use.
- ◆ Idle level is the amount of backlight on the display when the printer is in user idle mode.
- ◆ Active Level (In Dock) is the amount of backlight on the display while the printer is docked in the 6054/6055 before it goes into idle mode.
- ◆ Idle Level (In Dock) is the amount of backlight on the display while the printer is docked in the 6054/6055 when it is idle mode.

## Printing

---







When and how you print depends on your printer's application. It may print

- ◆ only after you press a certain key
- ◆ automatically as soon as you press a key
- ◆ automatically with no input from you
- ◆ one label or a strip of labels.

## Using the Input Panel

To open the printer's input panel, touch the Diamond key.



Key(s)	Description
	Accepts data or menu selection.
	Closes any open windows.
 or 	Displays upper-case or lower-case alphabetic input panel.
	Displays numeric input panel.
	Displays special character and symbol input panel.

## Scanning Bar Codes

---

Your printer may have a built-in scanner.

To scan a bar code:

1. Point the scanner at a slight angle, approximately 4 – 8 inches from the bar code symbol.
2. Press the trigger or other key specified by your System Administrator.

**Caution:** Do not stare into the beam.

The scanner LED is above the display.

Scanner LED	Description
Green	Successful scan.
Yellow	Unsuccessful scan.

If the bar code does not scan:

- ◆ Change the scanner's angle slightly and try again.
- ◆ Clean the scanner window. See "Cleaning" in Chapter 5 for more information.
- ◆ Move the scanner 4 – 8 inches away from the bar code. Adjust this distance as needed to find the correct distance.
- ◆ Try scanning another bar code that you have scanned successfully. If that scan is successful, the scanning problem is with the bar code.
- ◆ Move to a more dimly lit area.
- ◆ Ensure there are no voids (streaks) in the bar code symbol.

If the scan is still unsuccessful, ask your System Administrator to perform a scanner test.

## Certification Note

---

This product is certified to be a Class II laser product with the United States DHHS Center for Devices and Radiological Health and complies with 21CFR1040.10 and 1040.11 except for deviations pursuant to Laser Notice No. 50, dated July 26, 2001, The scanner emits less than a 2.0 milliwatt beam of laser light from the scanning window. Laser light in excess of Class I limits must be inside a protective cover. No maintenance is required to keep this product in compliance with EN 60825, IEC60825, and DHHS Regulation 21, Subchapter J. No controls are provided for operation or maintenance.

**Caution:** Use of controls, adjustments or performance of procedures other than those specified herein may result in hazardous laser light exposure.

Class II laser scanners use a low power, visible light diode. As with any very bright light source, the user should avoid staring directly into the light beam. Momentary exposure to a Class II laser is not known to be harmful.

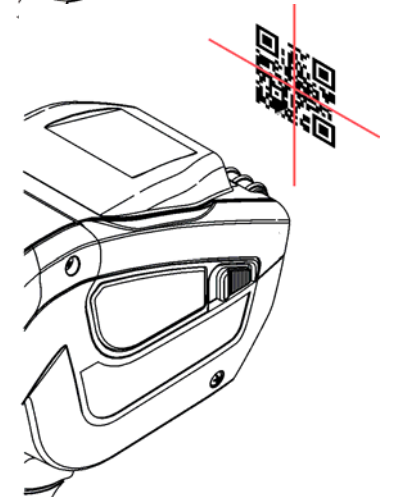
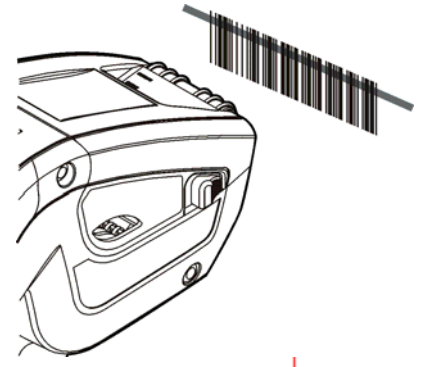

This chapter explains how to configure the printer.

## Selecting the Supply Type

---

1. Turn on the printer.
2. Touch the **Home** key.
3. Select **Printer Config.**
4. Select **General Settings.**

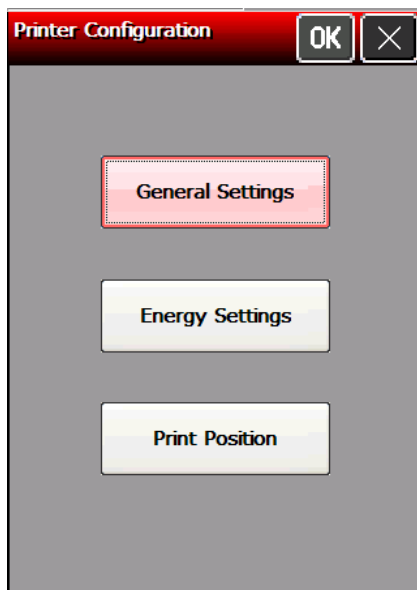

5. If your supplies have black mark, check **Use Black Mark.**



6. If you want the printer to tell you if your print job will print off the edge of the supply, check **Generate Off Tag Warning.**
7. Touch **OK** when finished.

## Adjusting the Print Contrast

---

To adjust the print contrast:

1. Turn on the printer.
2. Touch the **Home** key.
3. Select **Printer Config** and then **Energy Settings**.
4. Touch the left or right arrows to increase or decrease the contrast.

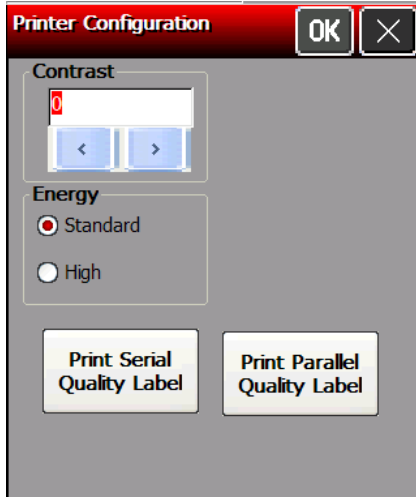

The higher the number, the darker the print; the lower the number, the lighter the print. The print contrast controls the darkness of the printing on your supply. The range is -100 to +100 and the default is 0. You may need to increase or decrease the print contrast depending on your supply type. Having the correct print contrast setting is important because it affects how well your barcodes scan and how long your printhead lasts.

5. Select the printhead energy as **Standard** or **High**. Use Standard for all other supplies; use High for synthetic supplies.
6. Select **Print Serial Quality Label** to print a label with bar codes to scan and check the quality of serial bar codes.



7. Select **Print Parallel Quality Label** to print a label with bar codes to scan and check the quality of parallel bar codes.



8. Touch **OK** when finished.

## Adjusting the Print Position

---

1. Turn on the printer.
2. Touch the **Home** key.
3. Select **Printer Config** and then **Print Position**.
4. Touch the left or right arrows to increase or decrease the Supply Position, Print Margin, Overfeed Distance, and/or Max Supply Length.

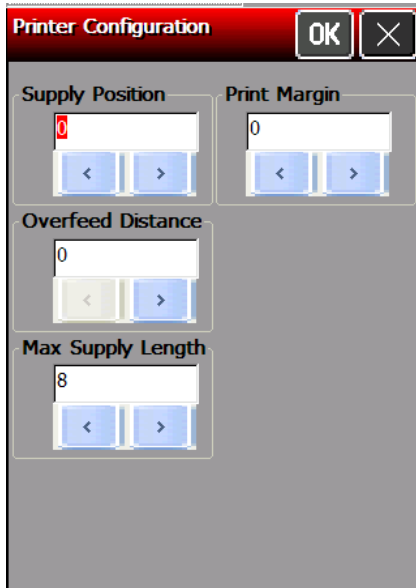

5. Touch **OK** when finished.

### Supply Position

Adjust the supply position to set where data prints vertically on the supply. The adjustments are in steps (0.00333 inch). The default value is 0. Increase the number to move the supply closer to the chute; decrease the number to move the supply away from the chute.

### Print Margin

Adjust the print margin to set where data prints horizontally on the supply. The adjustments are made in dots (0.0049 inch). The range is -99 – 99, the default value is 0. Increase the margin position to move print to the right, decrease to move print to the left.

### Overfeed Distance

Adjust the overfeed distance to set the distance that your supply is fed out of the chute after it prints. The adjustments are in steps (0.00333 inch). The default value is 0. Increase the number to feed more supply out of the chute; decrease the number to feed less supply out of the chute.

### Max Supply Length

Adjust the Max Supply Length if you are using supply that is longer than 8.0". The size of your supply is measured from top to bottom. The default value is 8. If your supply is shorter than 8" you do not need to adjust this setting (the printer automatically detects supply that is 8" or shorter).





Caring for and properly maintaining your printer protects it and keeps it running smoothly.

This chapter explains how to

- ◆ clean the printhead, platen roller, sensors, and scanner window
- ◆ clear supply jams
- ◆ store the printer.

## Cleaning

---

It is important to keep the printer clean. You must clean five main areas:

- ◆ Display Screen
- ◆ Printhead
- ◆ Platen Roller
- ◆ Sensors
- ◆ Scanner Window

**Do not** use sharp objects to clean the printer.

**Do not** use household cleaners to clean the printer.

### Cleaning the Display Screen

Make sure the printer is turned off when cleaning the display. Slightly dampen a soft cloth with distilled water and gently wipe the display.

**Do not** use household cleaners.

### Cleaning the Printhead

Clean the printhead

- ◆ after using 7-10 rolls of supplies
- ◆ in extreme temperatures, humid conditions, or a dirty environment
- ◆ when you see voids in the print
- ◆ after a supply jam.

**CAUTIONS:** The following actions may damage the printhead and void your warranty.

- ◆ **Do not** use silicone to clean or lubricate.
- ◆ **Do not** use sharp objects to remove adhesive or label particles from the printhead area.
- ◆ **Do not** touch the printhead with your fingers.



To clean the printhead:

1. Turn off the printer.
2. Open the supply cover and remove the supplies.
3. Check the supply holder for adhesive buildup and clean it if necessary.
4. Ground yourself by touching a metal object other than the printer. Grounding prevents electrostatic discharge, which may damage your printer.
5. Clean the printhead area of all adhesive and label particles using a Cleaning Pen or a soft cloth moistened with isopropyl alcohol.

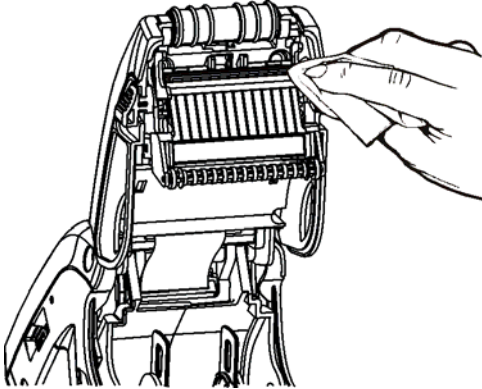

6. Reload the supply roll and close the supply cover.

### **Cleaning the Platen, Liner Drive, and Pinch Rollers**

Clean these rollers when you see significant adhesive build-up or when a label is wrapped around them.

1. Turn off the printer, open the supply cover, and open the label deflector.
2. Remove the supplies.
3. Hold the printer upright and gently push down on the label deflector. It may be stiff.
4. Use a dry, soft-bristle brush, such as a toothbrush, to clean the rollers.

If the brush does not remove all adhesive, moisten a cotton swab with isopropyl alcohol and run the cotton swab across the roller. Wait a few minutes for the printer to dry.

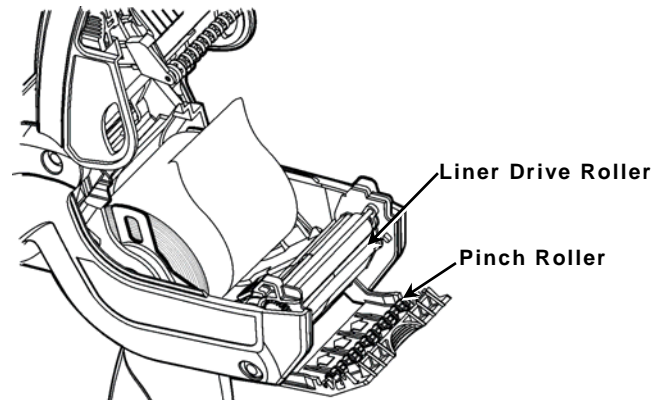
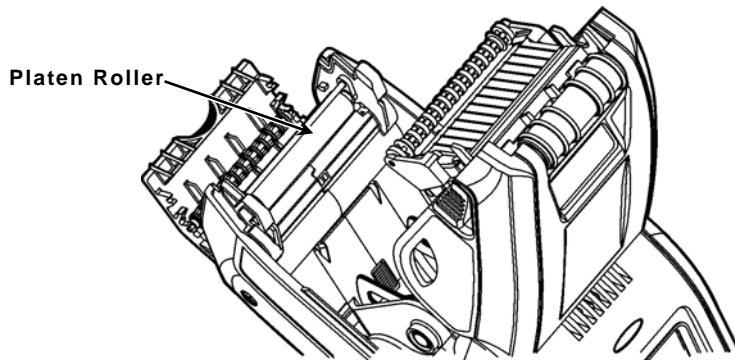

5. Reload the supplies, close the label deflector and supply cover.

## Cleaning the Black Mark Sensor

To clean the black mark sensor:

1. Turn off the printer and open the supply cover.
2. Remove the supplies.
3. Open the label deflector by gently pushing down on the label deflector.

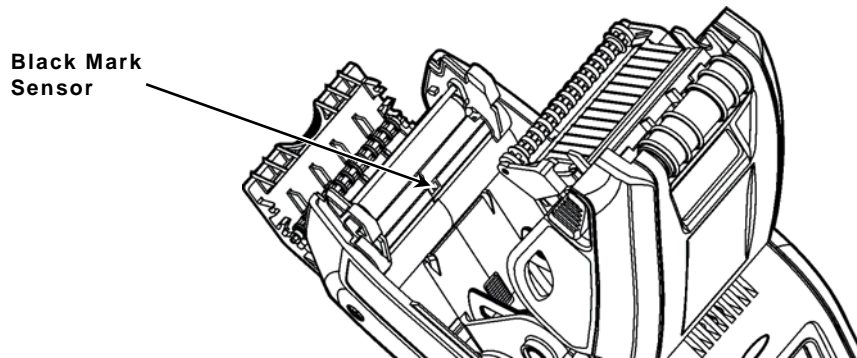

4. Clean the black mark sensor with a dry cotton swab.
5. Reload the supplies, close the supply cover and the label deflector.

## Cleaning the Scanner Window

Clean the scanner window whenever it appears to be dirty or smeared. To clean it:

1. Turn off the printer.
2. Moisten a soft cloth with distilled water. Do not use household cleaners to clean the printer.

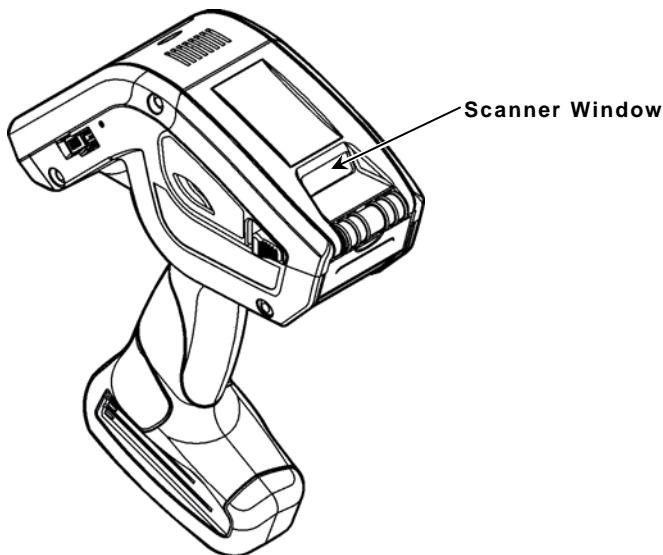

3. Gently wipe the window until it is completely clean.

**Note:** Pressing too hard on the window can crack the window or cause it to dislodge.

## Clearing Supply Jams

To clear a supply jam:

1. Turn off the printer and open the supply cover completely.
2. Open the label deflector by gently pushing down on the label deflector.
3. Remove the supplies.
4. Carefully remove any jammed supply.

**Note:** **Do not** pull the jammed supply out through the front of the label deflector. **Do not** use sharp objects to remove jammed supplies.

5. Clean any adhesive build-up.
6. Reload the supplies, close the supply cover, and close the label deflector.

## Storing the Printer

---

**Do not** store the printer in or near

- ◆ magnetic fields
- ◆ wet or damp areas
- ◆ dirty or dusty areas
- ◆ areas of intense vibration or shock.

# TROUBLESHOOTING

This section lists some common printer problems and their solutions.

Problem	Solution
Printer does not feed.	Switch to a fully charged battery. Close the supply cover completely. Load the supply correctly. See “Loading Supplies” in Chapter 3 for more information. Check the platen roller for jammed labels. Make sure the pinch roller is in place.
Printer does not print.	Switch to a fully charged battery. Load the supply correctly. See “Loading Supplies” in Chapter 3 for more information. Clean the printhead. See “Cleaning the Printhead” in Chapter 5 for more information.
Print has voids or is too light.	Load the supply correctly. See “Loading Supplies” in Chapter 3 for more information. Close the supply cover completely. Switch to a fully charged battery. Clean the printhead. See “Cleaning the Printhead” in Chapter 5 for more information. Check the supply for damage or defects.
Printer partially prints on the supply and fails to respond to the keypad or trigger.	Load the supply correctly or load new supplies, if necessary. See “Loading Supplies” in Chapter 3 for more information. Clear any supply jams. Clean the printhead. See “Cleaning the Printhead” in Chapter 5 for more information. Switch to a fully charged battery.
Scanner does not scan a bar code.	See “Scanning Bar Codes” in Chapter 4 for more information.
The display does not turn on.	Make sure the power is on. Switch to a fully charged battery.

## Checking the Software Version

To check the Software version of the printer, the Ultra Class library, the scanner configuration, printer diagnostics, and the Application version:

1. Turn on the printer.
2. Touch the **Home** key.
3. Select **About**.
4. Scroll to check the versions of the API, print engine, etc.
5. Touch **Done** when finished.

# Printing a Test Label

To print a Test Label:

1. Touch the **Home** key.
2. Select **Printer Diag.**
3. Select **Diagnostic Labels** from the Print Engine Tests window.
4. Select one of the following from the Diagnostic Labels window.

**Select:**

**The following labels print:**

Information Labels

M06057STD	Diagnostics Info
Service Packs	None
PE Version	V1.1 (AK)
Total Inches:	00000490
Hi-Energy Inches:	00000000
Battery:	7.534V (60%)
PH Dot Resist Avg:	358
Bad Dot Count:	0

Settings Diagnostics Info	
Sensor:	Black Mark
Stock Offset:	0
Contrast:	0
Speed:	Best Available
Network Diagnostics Info	
Adapter Name:	SDCCF10G1
IP Address:	0.0.0.0
MAC Address:	00:01:02:0A:40:7E

Prints a label that contains the printer information.

Checkerboard Label

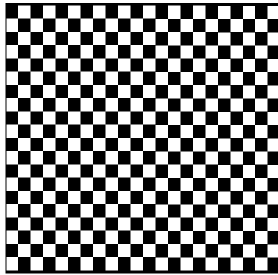

Prints a label to verify that the printhead strobes are working. If your printed sample has fewer lines or no lines, keep the sample and call Service.

Gray Scale Label

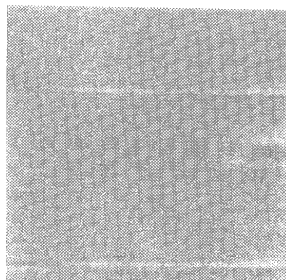

Label with voids

The gray scale test checks the uniformity of the printing. The printed sample should be uniformly gray across the supply. If you see voids, especially on the edges, keep the sample and call Service.

Serial Barcode Label

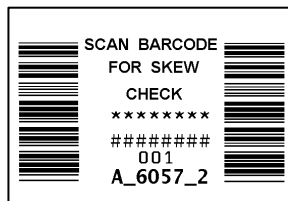

A label prints bar codes for you to scan to check the quality of serial bar codes.

Parallel Barcode Label



A label prints bar codes for you to scan to check the quality of parallel bar codes.

## Error Codes

---

This section lists common error codes and their descriptions.

<b>Code(s)</b>	<b>Description</b>
004 - 005	Supply size is incorrect. Reload the correct supplies.
267 – 271 410 - 413	Communication error. See your System Administrator.
703 - 704	Supply Error. Load supplies or make sure they are loaded correctly. See “Loading Supplies” in Chapter 3 for more information.
706	Remove any jammed supplies. See “Clearing Supply Jams” in Chapter 5 for more information. If the supply is not jammed or you have removed the jam, and the error continues, see your System Administrator.
750	Printhead is overheated. Turn off the printer to let it cool.
751 - 753	The printer sensed a problem with a mark on the supplies. Check the supplies to see if they are loaded correctly.
756	The printer is out of supplies. Load supplies. See “Loading Supplies” in Chapter 3 for more information.
757	The calibrated supply length differs by plus or minus .25 inches from the format. Load supplies.
758	Check supply. Remove any printed labels. Check for a label jam. Clear the supply path or reload supplies.
762	Low battery. Recharge the battery. See “Charging the Main Battery” in Chapter 2 for more information.
763	Waiting to dispense label. Press the trigger.
768	Printhead error. See your System Administrator.
790 - 791	The printer is busy or has an error pending. Turn off the printer, wait two seconds, and then turn it back on.
904 – 911	System error. See your System Administrator.
SYSTEM ERROR VECTOR ##	System error. See your System Administrator.

## Technical Support

---

If these solutions do not work or you have a problem or error code not listed, see your System Administrator or call Service at the number listed on the back of this manual.





# SPECIFICATIONS & ACCESSORIES

A

## Specifications

---

<b>Dimensions:</b>	Width – 3.3" (84 mm) Length – 9.84" (250 mm) Height – 7.9" (201 mm) Weight – 2.0 lbs. (908 g) Shipping Weight – 5.9 lbs. (2.6 kg)
<b>Printhead:</b>	1.89" (48mm/384 dots) (203 dots per inch)
<b>Printing:</b>	Thermal direct (no ink /ribbon)
<b>Print Speed:</b>	Up to 5" (127 mm) per second
<b>Memory:</b>	128 MB DDR RAM; 256 MB NAND Flash
<b>Battery Type:</b>	7.4V Lithium-Ion 3.6V Lithium-Ion (internal)
<b>Battery Recharge Time:</b>	1 – 3 hours, depending on the charger used.
<b>Supply Sizes:</b>	Widths: 1.2", 1.5", and 2.0" (30mm, 38mm, and 51mm) adjustable between 1.2 – 2.0" (30 mm – 51 mm) Lengths .55" – 8.0" (14mm –203mm) Peel mode supports .785" (20 mm) or greater lengths. Non-Peel mode supports .55" (14mm) or greater lengths.
<b>Operating Temperature:</b>	40°F – 110°F (4°C – 43°C)
<b>Humidity (Operating &amp; Storage):</b>	5% – 90% non-condensing

## Accessories

---

This section lists some of the accessories available for your printer and their part numbers. For more accessories, refer to the *Accessories List* available on our Web site.

Part Number	Description
M09462	Single-Station Battery Charger
M09465	Four-Station Battery Charger
114226	Cleaning Pen
M06054	Network Control Module Use one module with up to four 6055 Docking modules
M06055	Docking Module Connects to the Network Control Module. Holds the printer, charges the battery while inside the printer, and allows Ethernet communication with the printer.
125859	USB Cable
12009502	Extra Battery







028028

Avery Dennison  
170 Monarch Lane  
Miamisburg, OH 45342

**1-800-543-6650 (In the U.S.A.)**  
**1-800-387-4740 (In Canada)**  
**[www.monarch.com](http://www.monarch.com)**

