

Référence pièce		D	D ₁	d	H	h	l	t	W	W ₁	L	Masse (g)	Prix unitaire
GRC	8	20	13	12	55	5.5	8	6.5	10	2	11	40	
	10	25	16	15	68		10	8	14		18	100	
	12	30	21	20	85	10	13	9.5	17	2.5	23	180	

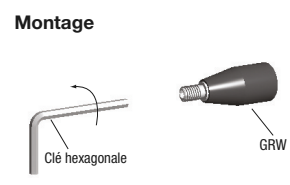

Référence pièce		D	d	d ₁	h	W	L	A	Masse (g)	Prix unitaire
GRW	6-28.5	14	11	8	28		10	0.5	13	
	6-42.5	18	15	10	40	3	12	2.5	29	
	6-52.5	21	17		50		13	2.5	42	
	8-40	20	17	10	39	4	12		24	
	8-55				54				44	
	10-67	23	20	12	66	5	16		74	
	10-75	23	20	12	74	5			77	

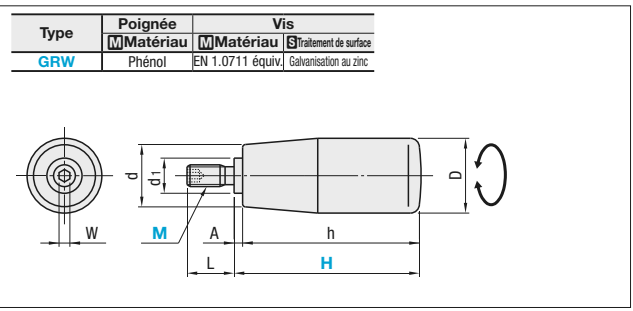
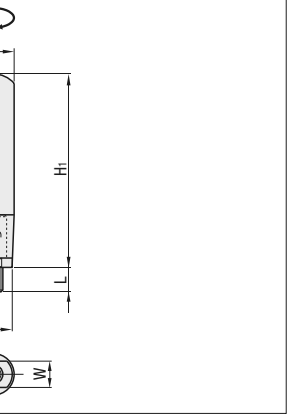
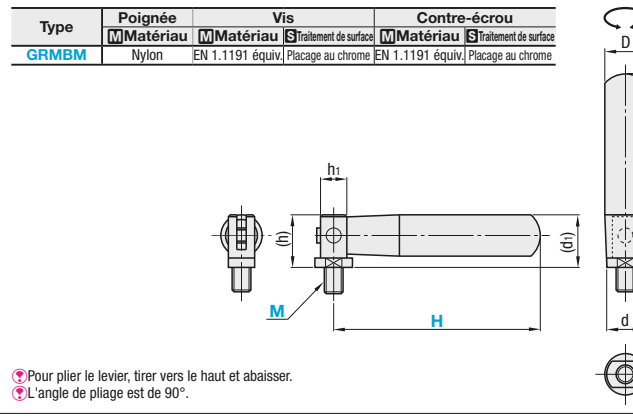

Référence pièce		H	D	d	(h)	L	h ₁	H ₁	(d ₁)	W	Masse (g)	Prix unitaire
GRMBM	8	55	19.6	16	20.9	12.5	9	55.5	23.3	12	42	
	10	81	19.7	16	27.6	12.5	9	80	29.45		80	
	10	104	22.6	19	27.8	16	11	103.5	31.1	14	155	

Ordering Example: GRC8 - 40, GRW8 - 55, GRMBM8 - 55

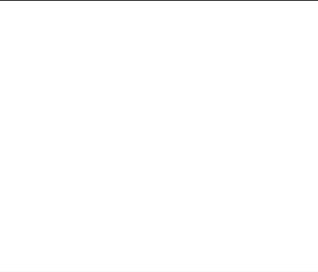
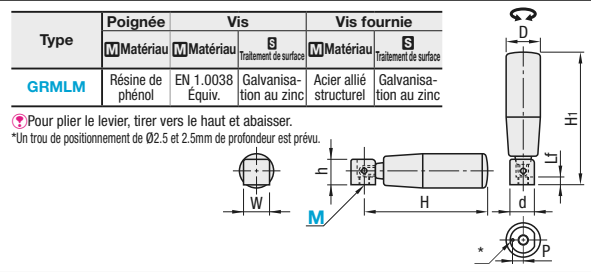

Référence pièce		H	D	d	h	Lf	H ₁	W	P	Vis fournie	Masse (g)	Prix unitaire
GRMLM	5	53	18	15.5	15	5	57	17	5.25	M5x10	55	
	6	80	23	18.5	19.5	6	87	20	6.5	M6x10	115	
	8	95	26	18.5	19.5	6	102	20	7	M8x14	137	

Ordering Example: GRMLM6

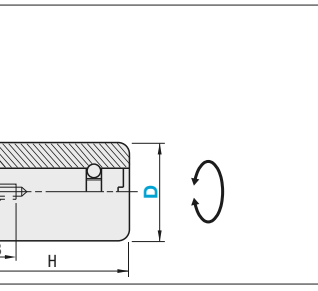
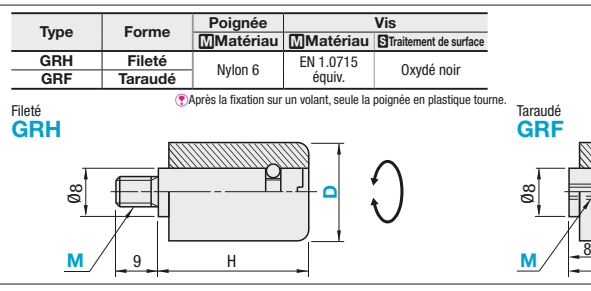

Référence pièce		Couleur de la poignée	H	Masse (g)	Prix unitaire
GRH	6-13	B (noir)	18.8	13	
	6-14	W (blanc)	20.8	14	
	6-16		23.8	16	

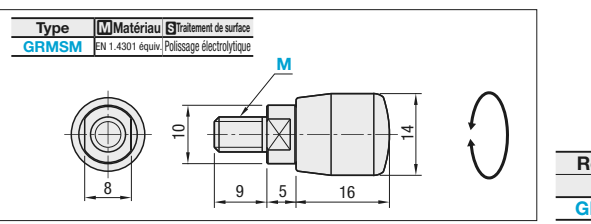
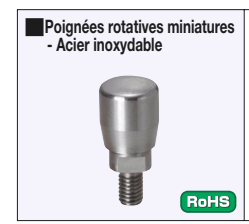

Référence pièce		Masse (g)	Prix unitaire
GRMSM	6	21	

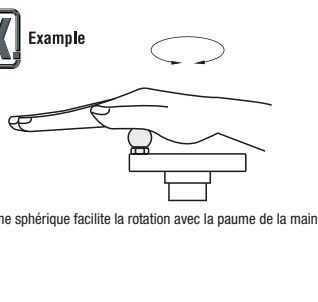
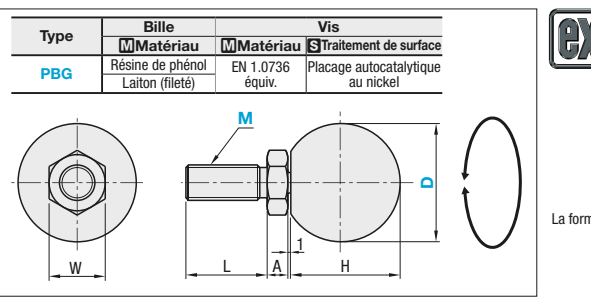

Référence pièce		D	H	L	W	A	Masse (g)	Prix unitaire
PBG	6	20	18				12	
		25	23			3.6	17	
		30	28				25	
		20	18				19	
		25	23			5	25	
		30	28				33	
		10	30			6	49	

Ordering Example: GRMLM5 - 13 - W, GRH6 - 16 - B, GRF5 - 25