

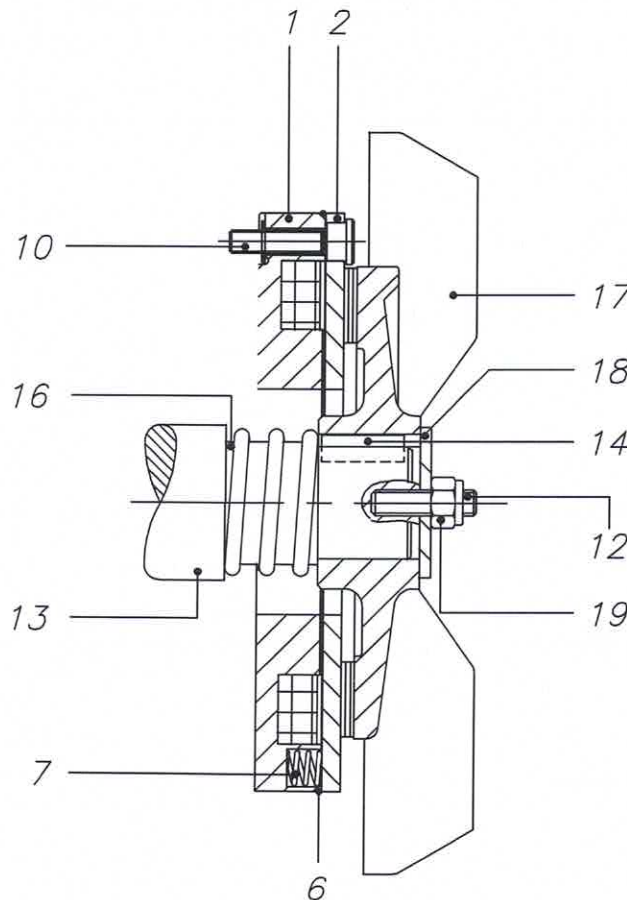

O.E.G. SPRING PRESSURE SAFETY BRAKES IN DIRECT CURRENT
MLCC TYPE

TECHNICAL DATASHEET

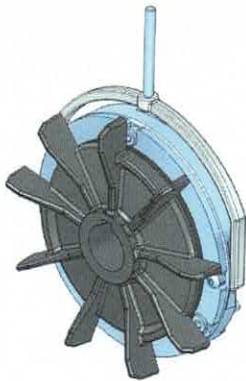

- | | |
|----|------------------------------------|
| 1 | Magnet casing |
| 2 | Mobile anchor |
| 6 | "O" ring |
| 7 | Thrust spring |
| 10 | Fastening screw |
| 12 | Stud bolt |
| 13 | Driving shaft |
| 14 | Key |
| 16 | Contrast spring |
| 17 | Fan |
| 18 | Washer |
| 19 | Air-gap adjusting self-locking nut |

The O.E.G. MLCC brake series are safety brakes, since they act in the absence of power supply through the pressure exerted by springs. When the coil housed in the magnet body (1) is energized, the armature (2) is attracted, against the force of the springs (7), thus leaving it free to rotate the shaft (13), on which is mounted the fan (3) sliding axially on the motor shaft (13). Disconnecting the power supply, the springs (7) push the armature (2) pushing it against the fan (3). In this way the shaft (13) is braked. The softer construction creates a redundancy that makes the equipment safe.

FEATURES

Braking torque from 3 Nm to 50 Nm.
Normal input voltage 103 V DC and 178 V DC from half-wave current rectifier (see "Electric Accessories").
All voltages from 12 V DC to 300 V DC available on request.
S1 Service, Class F insulation, watertight coil.
Asbestos-free noiseless friction packing.
Cast-iron braking fan. Steel flywheel fan molded up to size 100.
Possible assembly of hand release device.
Possible replacement of the single coil.
Minimum axial dimensions, which allow mounting under headset without engine modifications.
Vertical assembly with no added device.
Maximum silence even on single-phased motors.
Air-gap adjustments by means of a single nut.

TYPICAL APPLICATION

Woodworking machine.
Bottling machine.
Packaging machine.

DIMENSIONS

With reference to the drawing, see brake dimensions in the table.

Where present, the letter superscript indicates possible constructive alternatives that have to be considered coupled by apex (i.e. choosing C1 means you have GA1, X1, Y1, Z1).

	63	71	80	90	100	112	132L/160
M_F[Nm]	3	4	7	7/11	13/18	13/18	30/50
C	5	5	6	8	8	10	10
E	92	103	126	126	154	154	200
F	15	17	20	25	30	30	35
GA	17,3	19,3	22,8	28,3	33,3	33,3	38,3
H	21	21	23	23	26	29	38
I	43	93	116	116	139	139	178
J	39	41	42	43	50	60	70
K	3,7	3,7	3,7	3,7	3,7	7	7
L	20	20	22	23	28	28	37
L¹	30	30	40	40	40	40	40
M	30	30	45	45	60	60	80
P	M5	M5	M5	M5	M6	M6	M8
P¹	M6	M6	M8	M8	M10	M10	M10
Q	34	35	37	38	44	48	61
S	6	15	16	20	22	18	15
T	0,2	0,2	0,2	0,2	0,25	0,25	0,3
U	6,7	7,9	8,3	8,3	7,8	7,2	8,2
V¹	109	116	143	155	170	182	213
Y¹	200	200	250	250	300	300	400
PESO[daN]	1,06	1,29	2,08	2,09	3,57	4,51	7,35
P [W]	18	18	25	25	35	35	60

DRAWINGS

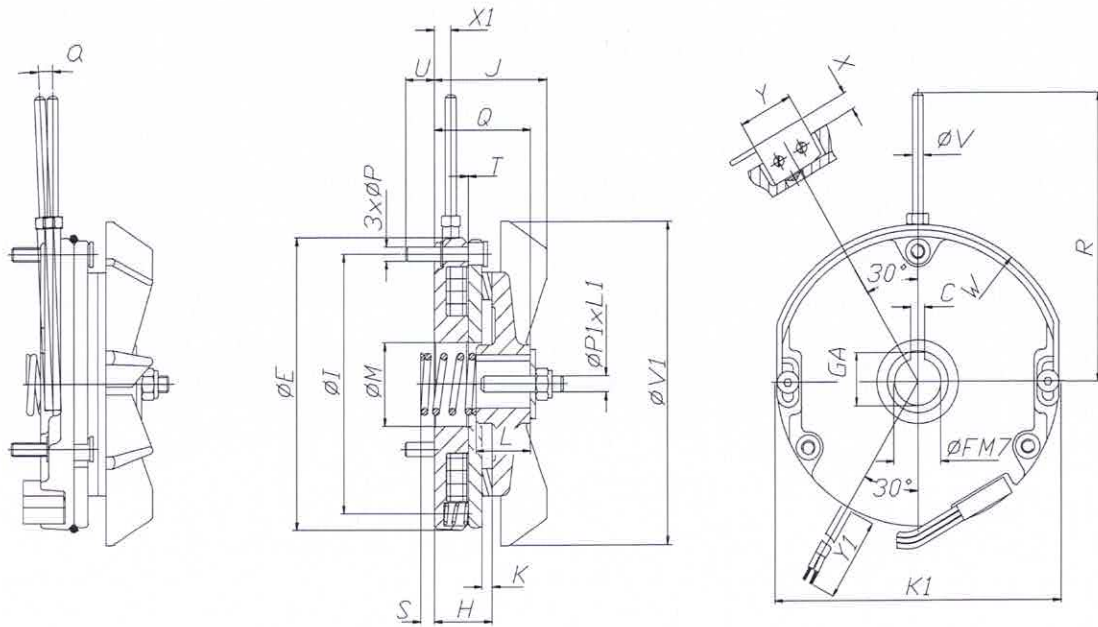

TECHNICAL INFORMATION

The brakes are supplied in the standard three-spring version. The braking torque is preset. Brakes with higher or lower braking torques with respect to the standard version can be supplied on request.

BRAKE SELECTION

The following table shows the characteristic values to be taken into consideration for the check calculation of the correct brake selection.

		63	71	80	90	100	112	132L	160
Braking torque	M_F [Nm]	3	4	7	7/11	13/18	13/18	30/50	30/50
	T_{min} [mm]	0,2	0,2	0,2	0,2	0,25	0,25	0,3	0,3
Air Gap	T_{max} [mm]	0,5	0,6	0,6	0,6	0,65	0,65	0,7	0,7
	n_{max} [min ⁻¹]	6000	6000	3600	3600	3000	3000	3600	3600
Release lever height	X [mm]								
Brake disc moment of	J [kgcm ²]	3	5	10	11	30	34	50	50

inertia	$W_{tot}^{1)}$	250	250	375	375	500	500	1650	1650
	[MJ]								
Brake life	$W_2^{2)}$	30	40	60	60	80	80	132	132
	[MJ]								
t_1	[ms]	30	40	60	60	100	100	150	150
$t_1^{3)}$	[ms]	4	4	6	8	16	16	16	16
$t_2 DC^{4)}$	[ms]	20	40	60	90	120	140	180	200

1. For friction packing wear up to a 1 mm thickness
2. Between two wear adjustments from T_{min} to T_{max}
3. Opening on AC side
4. Opening on DC side

BRAKE WORKING DIAGRAM FOR CALCULATIONS

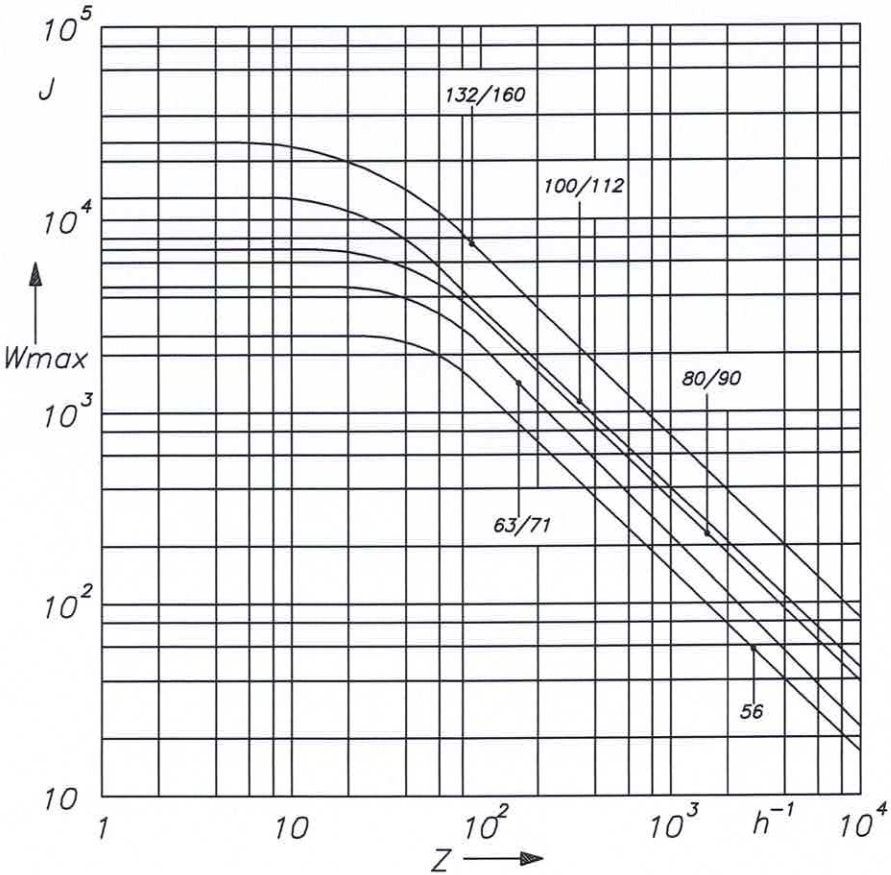

LAVORO MASSIMO PER NUMERO DI INTERVENTI/ORA