

CAD generated and maintained drawing. All printed and electronic copies outside of Griswold's engineering database are "Uncontrolled" and shall be used for reference only.

REV.	DESCRIPTION	BY	APP.	DATE
A	1.5 X 1 - 6AA ANSI PUMP ASSEMBLY	M.H.		

NOTES: UNLESS OTHERWISE SPECIFIED

1. DIMENSIONS AND TOLERANCES PER ANSI Y14.5M-1982.
2. * INDICATES DIMENSIONS AND/OR FEATURES MODIFIED ON CURRENT REVISION LEVEL.

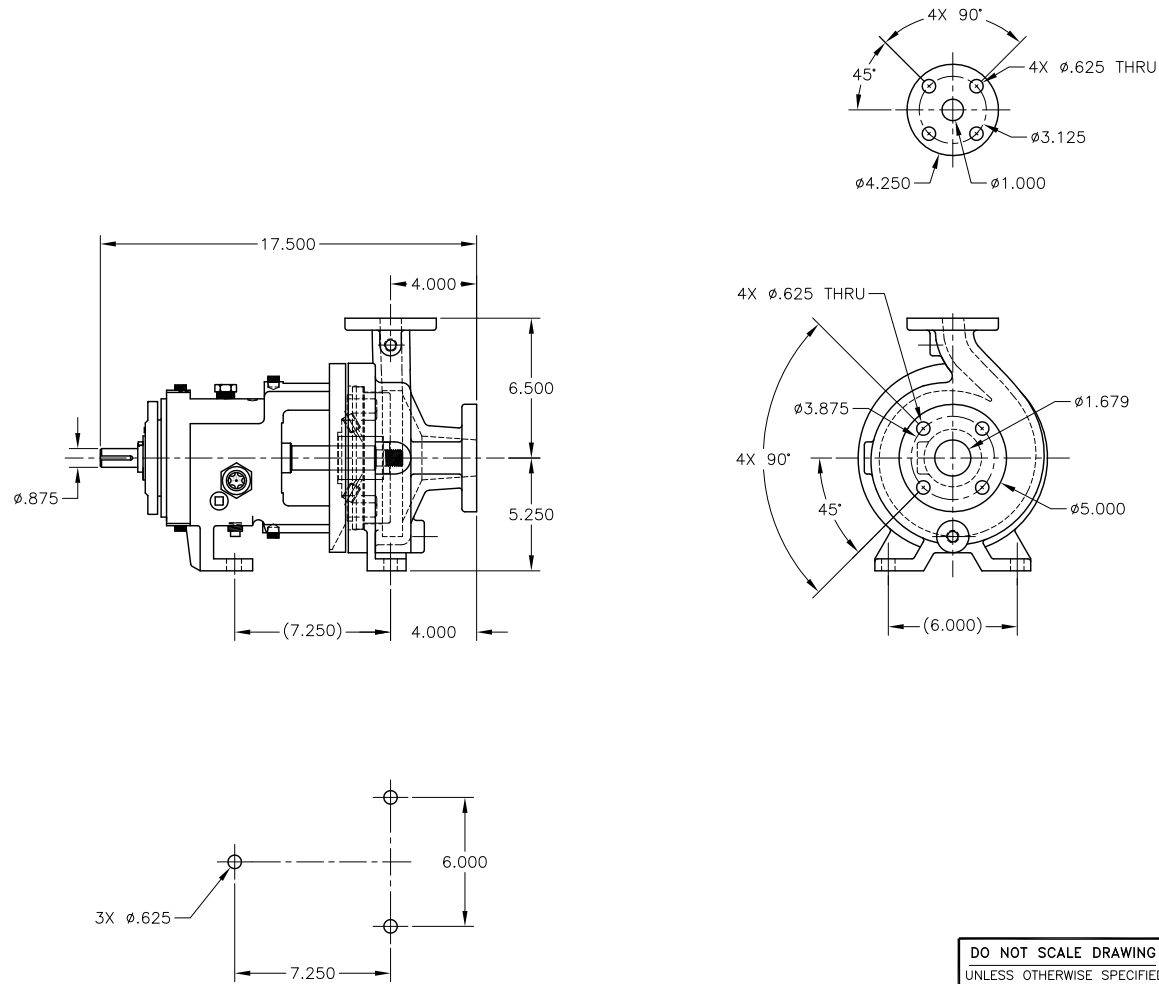

DO NOT SCALE DRAWING UNLESS OTHERWISE SPECIFIED DIMENSIONS ARE IN INCHES TOLERANCES ARE: FRACTIONS ± - DECIMALS .XX ± - .XXX ± - ANGLES ± - SCALE 1/1 SHEET 1 OF 1		GRISWOLD 22080 15th STREET ST. GRAND TERRACE, CA 92313 PHONE: (800) 843-2223, FAX: (800) 752-2929	
TITLE ASSEMBLY, 1.5 X 1 - 6 AA ANSI		DRAWN BY M. HIATT	DATE 04/22/10
CHECKED BY DATE		ASSY. NO. DRAWING NO. 1.516AA	REV. A

THIS DOCUMENT AND ITS CONTENTS ARE PROPRIETARY TO WILSON PUMP AND ENGINEERING CO. ANY REPRODUCTION, DISCLOSURE OR USE OF THIS DOCUMENT IS EXPRESSLY PROHIBITED EXCEPT AS OTHERWISE AGREED TO IN WRITING.