

0.72°/Geared Stepper Motor and Driver Package RKII Series

<Additional Information>

- Technical reference → Page H-1
- Regulations & Standards → Page I-2



● For detailed information about regulations and standards, please see the Oriental Motor website.

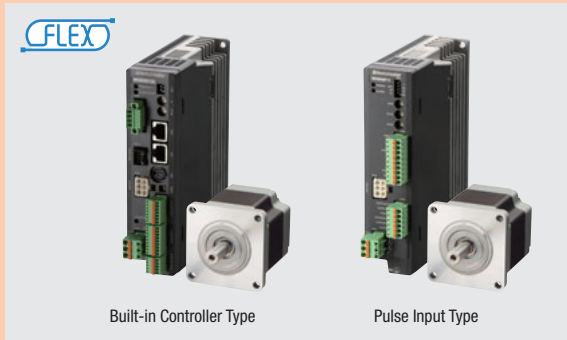

It is a 0.72° stepper motor and driver package with improved basic performance and ease of use, achieved by combining the newly developed high efficiency 0.72° stepper motor with a full digital control microstep driver to maximize motor performance.

- Starting from €357.00
- Increased Accuracy, Decreased Vibration, Increased Torque
- High Efficiency Allows for Reduced Power Consumption and Lower Heat Generation
- A Variety of Geared Types are Available to Suit the Application.
- 2 Driver Types to Choose from Built-in Controller Type **FLEX** / Pulse Input Type
- Various Easy-to-use Functions
- Improved Noise Resistance through Line Driver Connection

FLEX What is FLEX?

FLEX is the collective name for products that support I/O control, Modbus (RTU) control, and FA network control via network converters.

These products enable simple connection and simple control, shortening the total lead time for system construction.

Features

High-Efficiency at Low Price

The **RKII** Series offers significant improvements in motor performance, driver operation and functions compared to conventional products and is available at a new lower price. In this example, the **RKII** Series is €185.00 less.

- List Price starting from €357.00



Conventional Product:
RK Series
□60 mm
Standard Type
€585.00



RKII Series
Pulse Input Type
□60 mm
Standard Type
€400.00

Advanced Performance

● High Accuracy

The positioning accuracy of the **RKII** Series is $\pm 0.05^\circ$ (± 3 arcmin). When used in combination with a ball screw as shown in the figure on the right, the positioning accuracy is ± 0.0014 mm. The accuracy of a regular ground ball screw is ± 0.01 mm, thus the accuracy is high enough for positioning operation.

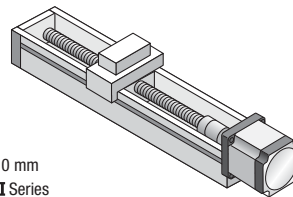

Conditions
· Ball screw lead: 10 mm
· Motor used: **RKII** Series

Stopping Accuracy: ± 0.0014 mm

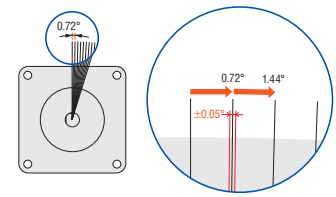

Positioning Accuracy $\pm 0.05^\circ$

● Low Vibration

Utilizing a full-time microstepping driver controlled by a digital system improves the vibration characteristics of the 0.72° stepper motor. Current control is also done by a high specification digital CPU. This product uses PWM control instead of PAM control resulting in a sinusoidal wave form in each phase, significantly reducing vibration.

◇ Current Waveform in Motor (theoretical figure)

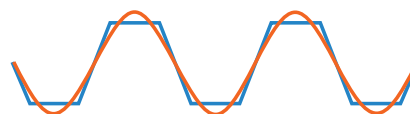

— **RKII** Series: Sinusoidal Wave
— Conventional Products: Trapezoidal Wave

Vibration is reduced when the motor current waveform changes from trapezoidal to sinusoidal.

◇ Vibration Characteristics Comparison

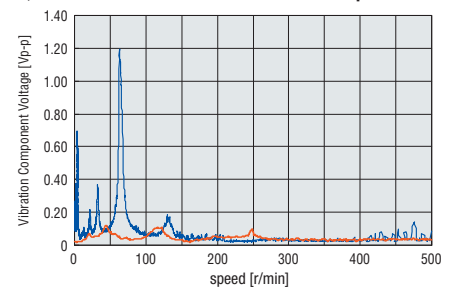

— **RK566AC** - ◇ Step Angle: 0.72°
— 1.8° Stepper Motor That Uses Micro Step Driver

● High Torque

The **RKII** Series is compact and produces high torque. The torque of the 42 mm frame size has increased 50%. This contributes to reduced positioning time and increased equipment tact time. The series includes 60 mm and 85 mm frame size to cover a wide torque range.

[Note]

● For 60 mm and 85 mm frame size products, the torque is equivalent to the conventional product.

◇ Torque Comparison □42 mm

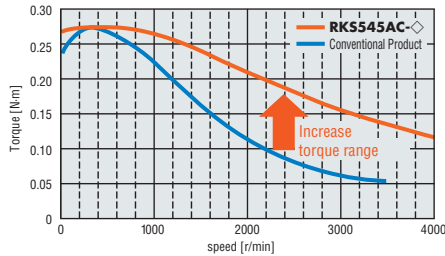

● High Efficiency, Power Saving, Low Heat Generation

By optimizing the motor material, loss has been greatly reduced and power consumption has been reduced by up to 47%. This results in reduced electricity cost and CO₂ emissions.

◇ Power Consumption Comparison

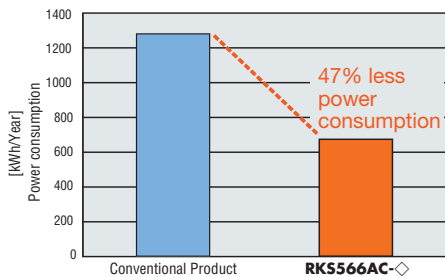

Operating Condition

- Speed: 1000 r/min
- Load Torque: 0.47 N·m
- Operating Time: 24 hours
(Operation 70%, Stand-by 25%, Off 5%)
365 days/year

◇ Motor Surface Temperature Comparison when Operating under the Same Conditions

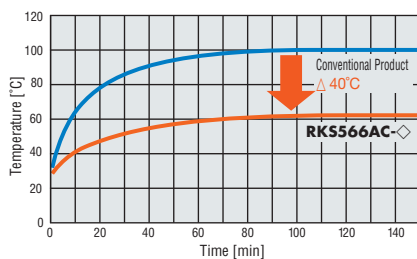

◇ Temperature Distribution by Thermography

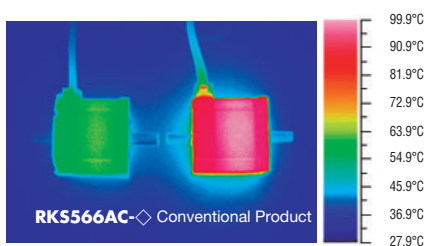

Easy-to-Use Functions

● Step Angle is Easy to Set

For pulse input type, 32 step angles can be selected. To easily upgrade from a 1.8° stepper motor, use the step angle setting switch to match the existing input pulses to the desired output speed and position. There is no software or control module required.

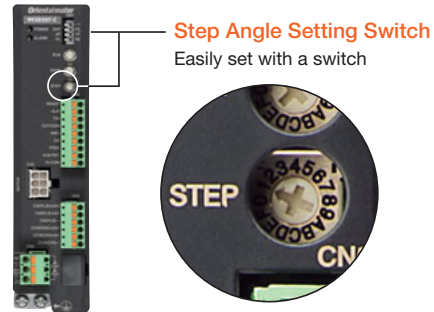

For built-in controller type, the value can be set between 200 p/rev~200000 p/rev.

Setting can be done by a control module, data setting software or RS-485 communication.

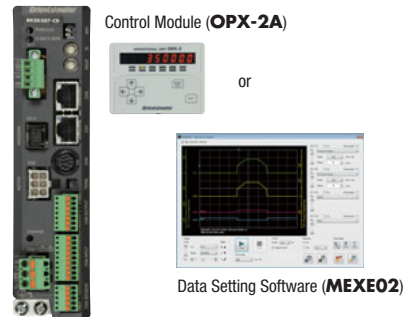

● Various Built-in Protective Functions

Protective functions are built-in to quickly respond when trouble occurs. The blink count of the alarm LED allows the problem to be quickly identified.

<Example of Alarm Types>

- Main circuit overheating
- Overvoltage
- Command pulse error
- Overcurrent
- Undervoltage
- Electrolytic capacitor error
- EEPROM error
- CPU error
- Automatic electromagnetic brake control error

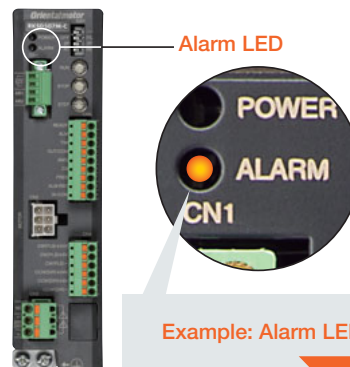

Example: Alarm LED blinks 3 times

Overvoltage alarm

[Cause]

- Power supply voltage exceeded its permissible value.
- A large inertial load was stopped suddenly or lifted or lowered.

Overview, Product Series

AC Input Motor & Driver

0.36°/Geared
αSTEP
Absolute
AZ

0.36°/Geared
αSTEP
AR

0.72°/Geared
RKII

DC Input Motor & Driver

0.36°/Geared
αSTEP
Absolute
AZ

0.36°/Geared
αSTEP
AR

1.8°/0.72°
/0.36°
CVK

0.72°/0.36°
/Geared
CRK

1.8°/Geared
RBK

Motor Only /Driver Only

1.8°/0.9°
PKP/PK

Geared
PKP/PK

0.72°/0.36°
PKP/PK

Driver

Accessories

● **Space Saving**

This new driver has a compact and slim body through the rearrangement of the internal components to optimize space. Multiple drivers can now be installed in contact with each other, making it possible to increase the number of axes within the same equipment space.

● When drivers are installed in contact with each other, the allowable ambient temperature range is 0~40°C.

Compact Slim Body Driver

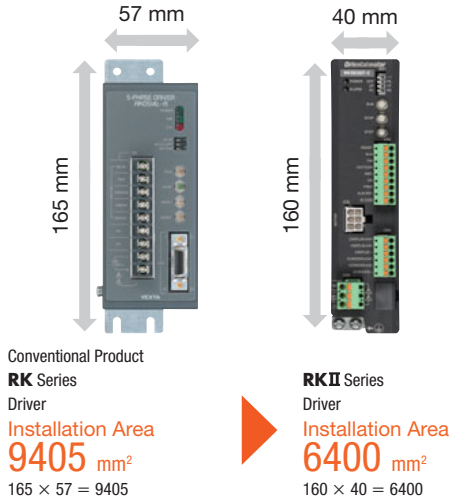

Multiple Drivers can be Installed in Contact with Each Other

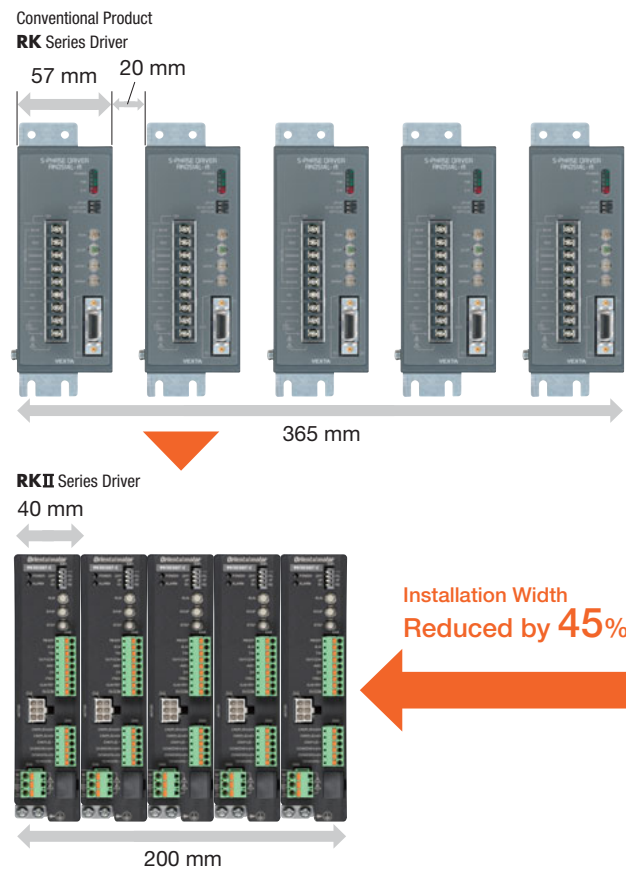

● **Easy Wiring**

Screwless I/O connectors eliminate the need for soldering or special crimping tools. The motor connector can be connected easily by using a dedicated cable. This will reduce wiring time, prevent mis-wiring and reduce maintenance.

◇ **I/O Connector Wiring**

- No soldering
- No special crimping tools
- No need to manage screw tightening torque

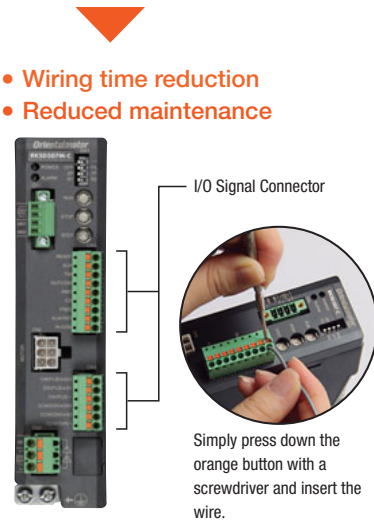

◇ **Motor Connector Wiring**

- No screw tightening
- No need to manage tightening torque
- No need to worry about mis-wiring



2 Driver Types Available Depending on the System Configuration

2 types of **RKII** Series drivers are available, depending on the master control system in use.

Built-in Controller Type **FLEX**

● When Controlling with I/O

① I/O

● When Controlling from Computer or Touch Screen (HMI)

② Modbus (RTU)

● When Controlling with Serial Communication

② Modbus (RTU)

● When Controlling with FA Network

③ FA Network

② RS-485

With this type, the operating data is set in the driver, which can then be selected and executed from the host system. Host system connection and control are performed with ① I/O, ② Modbus (RTU)/RS-485 or ③ FA network.

Pulse Input Type

This type executes operations by inputting pulses into the driver. It controls the motor using a positioning module (pulse generator).

Control System Configuration for Built-in Controller Type

① I/O Control

The positioning module (pulse generator) function is built into the driver, and therefore an operation system using I/O can be created by connecting directly to a switch box or PLC. A positioning module is not necessary on the PLC side, saving space and simplifying the system.

● Example of Using a Switch Box

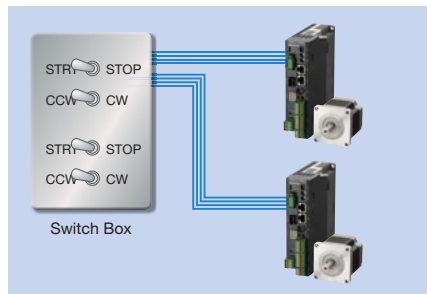

Operating data is set in the driver, and the motor can be started or stopped simply by connecting a switch. Control can be performed easily without using PLC.

Easy Control

Low-Cost Design

● Example of Using PLC

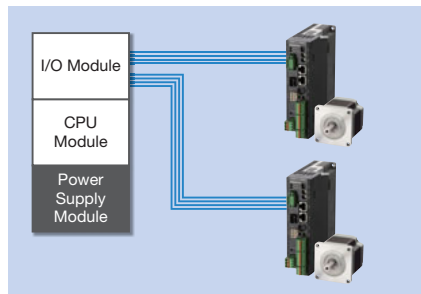

When using PLC, an operation system can be created by connecting directly to an I/O module. A positioning module is not necessary on the PLC side, therefore space is saved and the system is simplified.

Easy Control

Low-Cost Design

Space Saving

● Example of Using PLC and a Touch Screen

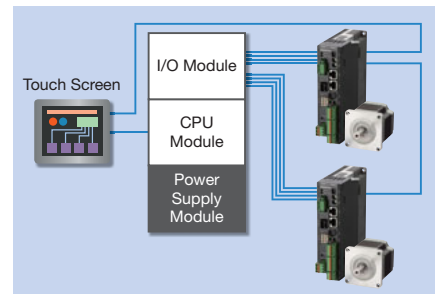

Normally, the motor is started and stopped with I/O. Changing the operating data settings and displaying the monitors and alarms is performed with the touch screen using Modbus (RTU) communication. When there is a lot of setup work, changes can be easily performed on the touch screen, and the burden of creating ladders is reduced.

Easy Control

Support for Small Lots of Multiple Products

② Control via Modbus (RTU)/RS-485 Communication

RS-485 communication can be used to set operating data and parameters and input operation commands. Up to 31 drivers can be connected to 1 serial communication module. There is a function that enables multiple shafts to be started simultaneously. The Modbus (RTU) protocol is supported and can be used to connect to touch screens and computer.

Easy Control

Simple Wiring

Supports Brands of Serial Modules

Motor Controlled by Computer

Simplified System

③ Control via FA Network

By using a network converter (sold separately), CC-link, MECHATROLINK or EtherCAT communication are possible. These can be used to set operating data and parameters and input operation commands.

Easy Control

Simple Wiring

Multi-Axis Control at Low Cost

Overview, Product Series

AC Input Motor & Driver

0.36°/Geared **αSTEP Absolute AZ**

0.36°/Geared **αSTEP AR**

0.72°/Geared **RKII**

DC Input Motor & Driver

0.36°/Geared **αSTEP Absolute AZ**

0.36°/Geared **αSTEP AR**

1.8°/0.72°/0.36° **CVK**

0.72°/0.36°/Geared **CRK**

1.8°/Geared **RBK**

Motor Only /Driver Only

1.8°/0.9° **PKP/PK**

Geared **PKP/PK**

0.72°/0.36° **PKP/PK**

Driver

Accessories

Built-in Controller Type

Because the driver has the information necessary for motor operation, the burden on the host PLC is reduced. The system configuration when using multi-axis control has been simplified.

Settings are configured using a control module (sold separately), data setting software or RS-485 communication.

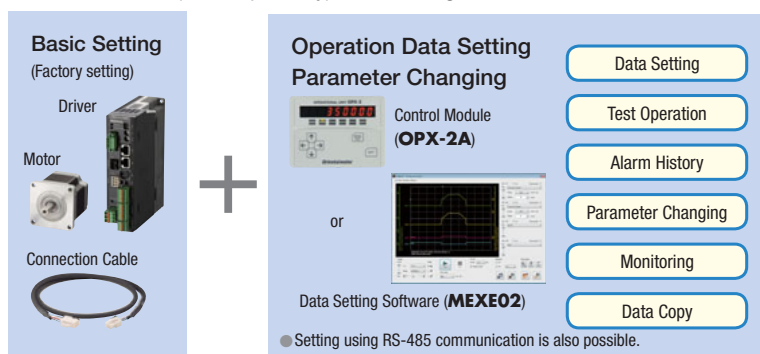

● Operation Types

In the built-in controller type, the operating speed and traveling amount of the motor are set with operating data, and operation is performed according to the selected operating data. There are four types of motor operations.

Item		Description		
Common	Control Method	I/O control		
		RS-485 Communication	Network Converter Connection Modbus RTU Protocol Connection	
	Position Command Input	Setting with operating data number	Command range for each point: -8388608~8388607 [step] (Setting unit: 1 [step])	
	Speed Command Input	Setting with operating data number	Command Range: 0~1000000 [Hz] (Setting unit: 1 [Hz])	
	Acceleration/Deceleration Command Input	Set with the operating data number or parameter. The acceleration/deceleration rate [ms/kHz] or acceleration/deceleration time [s] can be selected. Command Range: 0.001~1000.000 [ms/kHz] (Setting unit: 0.001 [ms/kHz]) 0.001~1000.000 [s] (Setting unit: 0.001[s])		
	Acceleration/Deceleration Processing	Velocity Filter, Movement Average Filter		
Return-To-Home Operation	Return-to-Home Modes	2-Sensor Mode	A return-to-home operation that uses a limit sensor (+LS, -LS).	
		3-Sensor Mode	A return-to-home operation that uses a limit sensor and a HOME sensor.	
		Position Preset	A function where P-PRESET is input at the desired position to confirm the home position. The home position can be set to the desired value.	
Positioning Operation	Number of Positioning Points	64 points (No. 0~63)		
	Operating Modes	Incremental Mode (Relative positioning)		
		Absolute Mode (Absolute positioning)		
	Operation Functions	Independent Operation	A PTP (Point to Point) positioning operation.	
		Linked Operation	A multistep speed-change positioning operation that is linked with operating data.	
		Linked Operation 2	A positioning operation with a timer that is linked with operating data. The timer (dwell time) can be set from 0~50.000 [s]. (Setting unit: 0.001 [s])	
	Start Methods	Operating Data Selection Method	Starts the positioning operation when START is input after selecting M0~M5.	
Direct Method (Direct positioning)		Starts the positioning operation with the operating data number set in the parameters when MS0~MS5 is input.		
Sequential Method (Sequential positioning)		Starts the positioning operation in sequence from operating data No. 0 each time SSTART is input.		
Continuous Operation	Number of Speed Points	64 points (No. 0~63)		
	Speed Change Method	Changes the operating data number.		
Other Operations	JOG Operation	Regular feed is performed by inputting +JOG or -JOG.		

Positioning Operation

<Operation Functions>

•Independent Operation

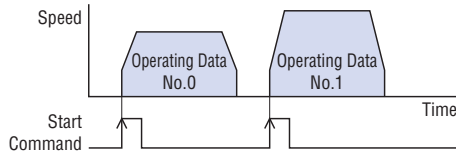

•Linked Operation

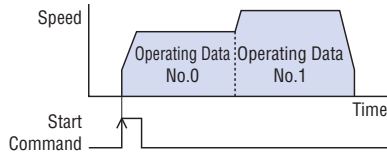

•Linked Operation 2

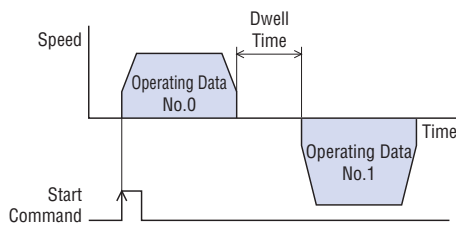

<Start Methods>

- Operating Data Selection Method
- Direct Positioning
- Sequential Positioning

Return-To-Home Operation

•2-Sensor Mode

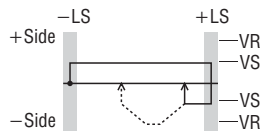

•3-Sensor Mode

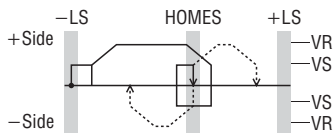

•Position Preset

Continuous Operation

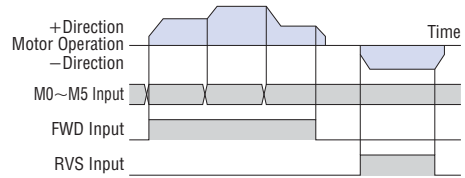

Other Operations

•JOG Operation (Test operation)

•Group Send Function

Modbus (RTU) communication and FA network have a function that enables multiple shafts to be started simultaneously. Multiple drivers can be grouped together, and when an operation command is sent to the master driver, all the drivers that belong to the same group as the master driver will operate simultaneously.

- Modbus (RTU) control: Support for simultaneous start, changes to traveling amount and speed and monitoring
- FA network control: Simultaneous start only

•Example of Modbus (RTU) Communication Control

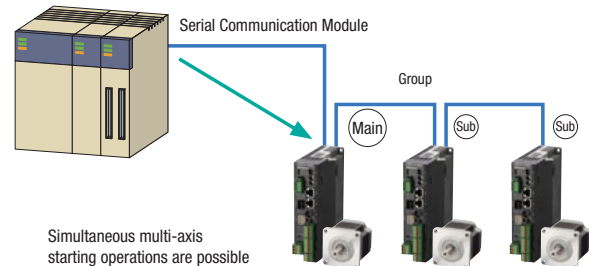

•Teaching Function

Teaching can be performed with the **OPX-2A** control module (sold separately) or the **MEXE02*** data setting software. The table is moved to the desired position, and the position data at that time is stored as the positioning data.

*The data setting software can be downloaded from the website. Please contact us for details.

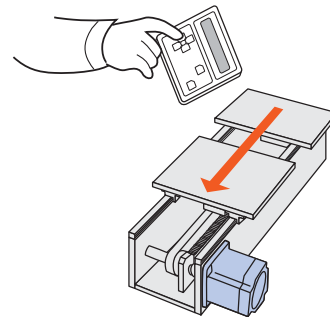

Overview,
Product
Series

AC Input
Motor &
Driver

0.36°/Geared
αSTEP
Absolute
AZ

0.36°/Geared
αSTEP
AR

0.72°/Geared
RKII

DC Input
Motor &
Driver

0.36°/Geared
αSTEP
Absolute
AZ

0.36°/Geared
αSTEP
AR

1.8°/0.72°
/0.36°
CVK

0.72°/0.36°
/Geared
CRK

1.8°/Geared
RBK

Motor Only
/Driver Only

1.8°/0.9°
PKP/PK

Geared
PKP/PK

0.72°/0.36°
PKP/PK





Driver

Accessories

Product Line of Motor

Types and Features of Standard and Geared Motors



*We provide encoder installed products, but only for the built-in controller products.

Type	Features	Permissible Torque and Max. Instantaneous Torque [N·m]	Backlash [arcmin (degrees)]	Basic Resolution [deg/step]	Output Shaft Speed [r/min]
Standard Type  with Encoder*	<ul style="list-style-type: none"> Basic motors of the RKII Series For encoder installed motors, functions for monitoring positioning data, detecting positioning gap are available. Resolution of encoder installed: 500 p/r. 	Maximum Holding Torque 6.3	—	0.72	6000
Low backlash	TS Geared Type (Spur Gear Mechanism)  <ul style="list-style-type: none"> High torque (Double of existing products) A wide variety of reduction gear ratios, high-speed operations Gear ratio: 3.6, 7.2, 10, 20, 30 	Permissible Torque 25 Max. Instantaneous Torque 38	10 (0.17)	0.024	833
	PS Geared Type (Planetary Gear Mechanism)  <ul style="list-style-type: none"> Less backlash (comparing with existing products) Highly permissible torque/ max. instantaneous torque A wide variety of gear ratios for selecting the desired step angle Centered shaft Gear ratio: 5, 7.2, 10, 25, 36, 50 	Permissible Torque 37 Max. Instantaneous Torque 60	7 (0.12)	0.0144	600
Non backlash	Harmonic Geared Type (Harmonic Drive)   <ul style="list-style-type: none"> Longer mechanical life (2 times of existing products) Higher torque (1.3 times of existing products) High positioning accuracy Highly permissible torque/ max. instantaneous torque High reduction ratio, high resolution Center shaft Gear ratio: 50, 100 	Permissible Torque 52 Max. Instantaneous Torque 107	0	0.0072	70

Note

- Above values are for reference only. These values vary depending on motor frame size and gear ratios.
- Harmonic drive and  are registered trademarks of Harmonic drive systems Inc or trademarks.

List of Drivers and Motors

Driver Type	Motor Type	Frame Size	Electromagnetic Brake	Power Supply Input	Driver Type	Motor Type	Frame Size	Electromagnetic Brake	Power Supply Input
Built-in Controller Type  	Standard Type	42 mm 60 mm 85 mm	●	Single Phase 200-240 VAC	Pulse Input Type 	Standard Type	42 mm 60 mm 85 mm	●	Single Phase 200-240 VAC
	Standard Type with Encoder	42 mm 60 mm 85 mm	—						
	TS Geared Type PS Geared Type Harmonic Geared Type	42 mm 60 mm 90 mm	●						

Oriental Motor offers geared motors, which come pre-assembled.

Based on torque, accuracy (backlash) and list price, the optimal type can be selected from the various geared motors.

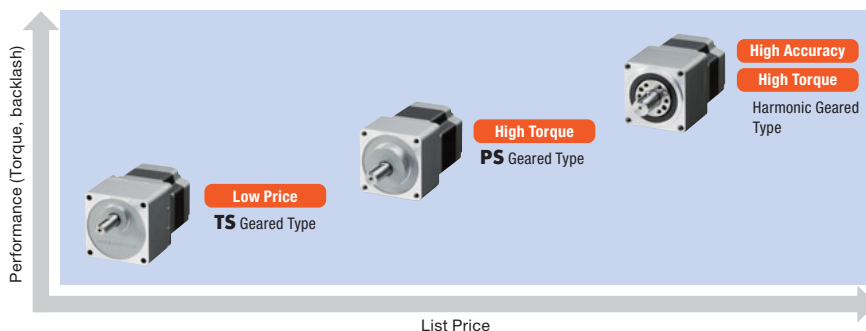

Features of the Product Line

Standard Type with Encoder (Built-in controller type only)

Encoder installed motors make it possible to monitor the present position and detect for errors.



● Positioning Monitor

This feature can be used to detect the position of the motor. For instance, to confirm normal operations, compare commanded position to the actual position.

● Return-to-Home Operation by Using Z-phase Signal

Z-phase signal can be utilized for the return-to-home operation. Using Z-phase signal, the return-to-home point will be detected with higher accuracy than single use of the return-to-home sensor.

● Detecting for Errors

The encoder will compare command position and encoder-count. If deviation exceeds the set value, a STEPOUT signal will be output. Positional errors due to rapid changes in load can be detected. An alarm signal for abnormality in deviation is also available.

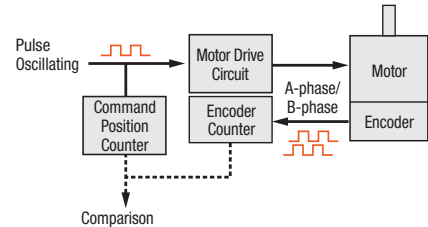

TS Geared Type

This geared type is made with a simple spur gear design. The torque and speed have been improved.



● Mechanism

Because of its high accuracy, this type has the same level of accuracy when compared to our tapered (TH) type without the added cost of tapering.

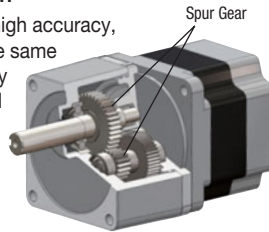

● Torque and Speed are Improved (compared with conventional product types)

The TS geared type realizes the improvement of permissible torque and at the same time, it can exert its maximum instantaneous torque. The rated input speed is increased to 3,000 r/min and the permissible speed range of the output shaft has been significantly increased as well. The motor allows for higher torque and shortens the time for positioning, because the maximum instantaneous torque range can be used for acceleration/deceleration.

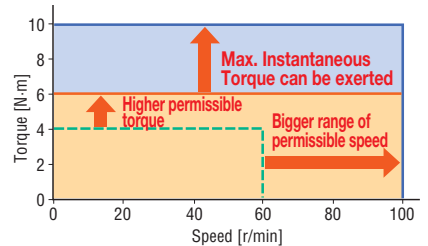
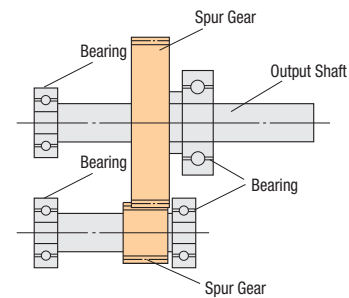

— RKS564 Gear Ratio 30, Max. Instantaneous Torque
 --- Conventional Product Types Permissible Torque
 — RKS564 Gear Ratio 30, Permissible Torque

PS Geared Type

The PS gear mechanism is comprised primarily of a sun gear, planetary gears and an internal tooth gear. The planetary gears design allows for higher output torque.



● Mechanism

There are gears inside used to distribute torque, which allows for higher torque than a spur gear design. The PS gear uses a higher accuracy gear design which provides for a lower backlash when compared to a spur gear design.



● Reduce Backlash (Compare with conventional product types)

Optimal design of gears reduced backlash. (Except: □42 mm)
 Positioning with higher accuracy is possible.

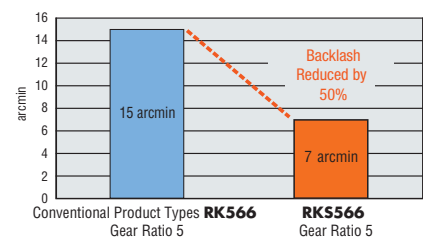
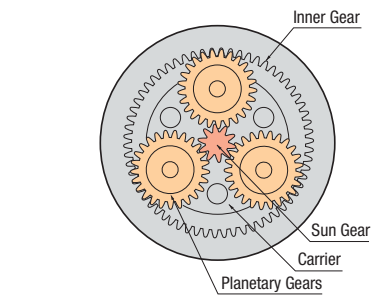

Overview, Product Series

AC Input Motor & Driver

0.36°/Geared
 αSTEP Absolute
 AZ

0.36°/Geared
 αSTEP AR

0.72°/Geared
 RK II

DC Input Motor & Driver

0.36°/Geared
 αSTEP Absolute
 AZ

0.36°/Geared
 αSTEP AR

1.8°/0.72°
 /0.36°
 CVK

0.72°/0.36°
 /Geared
 CRK

1.8°/Geared
 RBK

Motor Only /Driver Only

1.8°/0.9°
 PKP/PK

Geared
 PKP/PK

0.72°/0.36°
 PKP/PK

Driver

Accessories

Harmonic Geared Type

The mechanical life, permissible torque and maximum instantaneous torque are improved (compare with conventional product).



● **List Price starting from €839.00**
Compared to conventional products in the **RK Series**, the prices have become even more affordable.

● **Improved Rated Life (Twice the length of conventional products)**

The rated life has been increased from 5,000 hours (conventional products) to 10,000 hours. (Except □42 mm)

[Condition for rated life time]

- Torque : Permissible torque
- Type of load: Uniform load
- Input speed : 1,500 r/min
- Radial load : Permissible radial load
- Axial load : Permissible axial load

● **High Torque**

With more permissible and maximum instantaneous torque available, more load can be handled with the same size geared motor.

● **Structure**

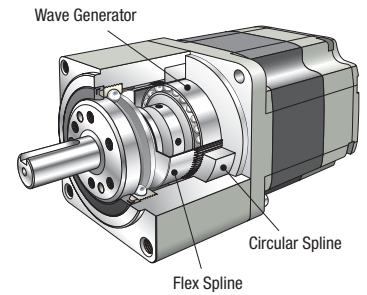

● **Comparison of Specification**

Product Name	RKS564AC -HS100-◇	Conventional Product
Permissible Torque N-m	10	8
Max. Instantaneous Torque N-m	36	28
Gear Ratio	100	
Lost Motion [Load Torque]	0.7 arcmin or less (±0.39 N-m)	

● **Comparison of Torque Characteristics**

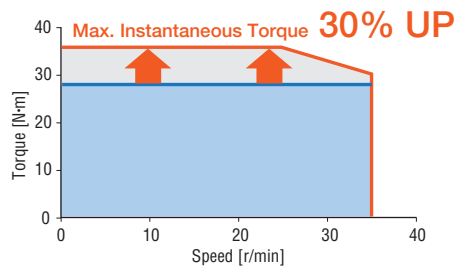
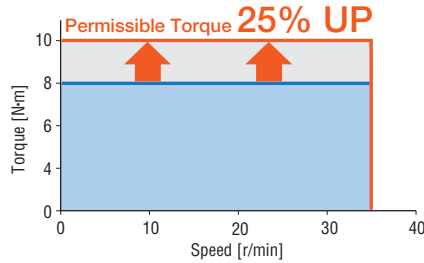

● **Surface Installation of Load Is Available**

This type permits installation of load directly on the rotating surface integrated with the shaft. (Except: □90 mm)

● **Appearance and Installation**

Example: This surface rotates with the shaft

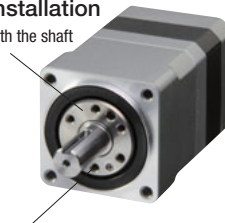

Tapped holes are provided on the rotating surface for load installation

<Example of Installation>

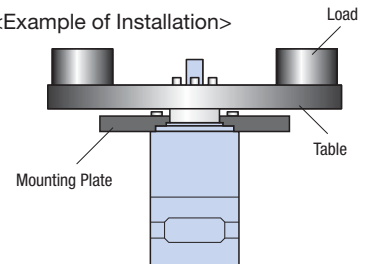

● **Application: Index Table**

This type not only reduces the number of parts/processes, but also improves reliability. They are also suitable for operating loads that receive moment loads.

<Conventional Mechanism> <Surface Mounting>

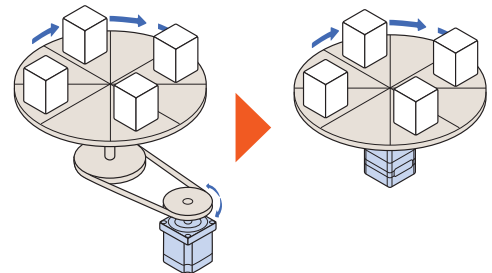

● Harmonic drive and are registered trademarks of Harmonic Drive systems Inc or trademarks.

Advantages of Geared Motors

Using geared motors bring many advantages, such as speed reduction, high torque and high resolution.

The Motor Can Drive a Large Inertial Load

If compared with a standard motor, the geared motors can drive larger inertial loads because its permissible load moment of inertia increases with the square of the gear ratio. This means that larger inertial loads can be driven with geared motors.

Improved Damping Characteristic at Start and Stop

If the inertial load is large or acceleration/ deceleration time is short, a geared motor can reduce damping more effectively and thereby ensure more stable driving compared to a standard motor. Geared motors are ideal for applications where a large inertia such as an index table or arm must be driven to perform quick positioning.



High Rigidity, Resistant to Torsional Force

Geared motors have high rigidity and are therefore resistant to torsional force. Therefore, compared to standard motors, geared motors are less subject to load torque fluctuation. This means that stability and high positioning accuracy can be ensured even when the load size changes.

Downsizing

If comparing the standard motor and the geared motor which have similar maximum holding torque, the frame size of the geared motor is smaller than the standard motor. Geared motors are effective when the equipment must be kept small and light.

Comparison of Load Moment of Inertia

	Motor Type	Motor Product Name	Load Moment of Inertia (10 times of Rotor Inertia)	Diameter of Inertial Load (Thickness: 20 mm, material: Aluminum)	Speed Range
	Standard Type	RKS564AC-◇	$1.6 \times 10^{-4} \text{ kg}\cdot\text{m}^2$	72 mm	0~6,000 r/min
	PS Geared Type (Gear ratio 5)	RKS566AC-PS5-◇	$67.5 \times 10^{-4} \text{ kg}\cdot\text{m}^2$	187 mm	0~600 r/min

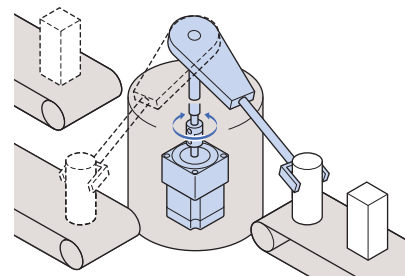
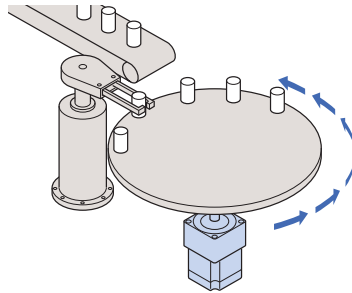

Application: Lifter

The application can perform high-precision stops, even with elevators and other mechanisms that perform vertical operations where the number of loads or weight of loads changes.

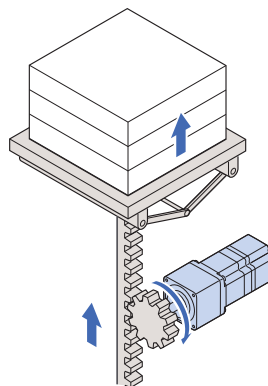

Application: Security Camera

The position can be held securely even when the camera sways from strong winds.

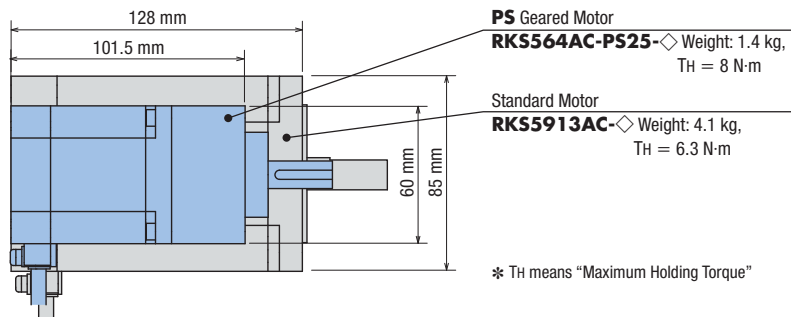
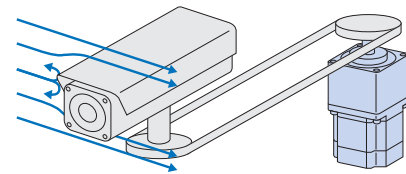

Overview, Product Series

AC Input Motor & Driver

0.36°/Geared
αSTEP Absolute AZ

0.36°/Geared
αSTEP AR

0.72°/Geared
RKII

DC Input Motor & Driver

0.36°/Geared
αSTEP Absolute AZ

0.36°/Geared
αSTEP AR

1.8°/0.72°/0.36°
CVK

0.72°/0.36°/Geared
CRK

1.8°/Geared
RBK

Motor Only /Driver Only

1.8°/0.9°
PKP/PK

Geared
PKP/PK

0.72°/0.36°
PKP/PK

Driver

Accessories

System Configuration

● Built-in Controller Type, Standard Type with Electromagnetic Brake

An example of a system configuration when used with either I/O control or RS-485 communication.

- *1 Not supplied
- *2 Only for products in which a connection cable is included.
- *3 Required for I/O control drive.

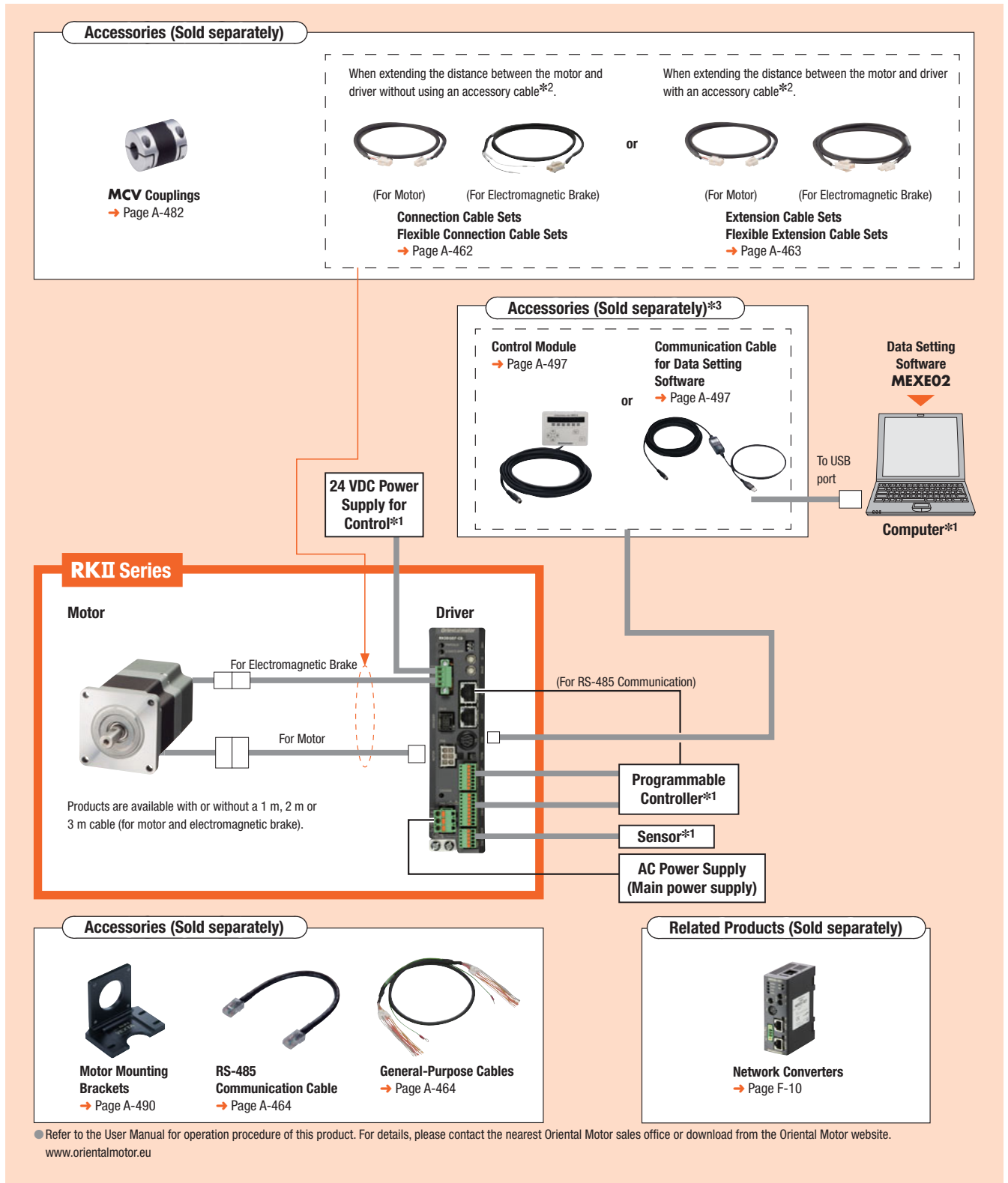

● Example of System Configuration

RKII Series RKS566MCD-3 €627.00	+	Sold Separately		
		Motor Mounting Bracket PAL2P-5 €13.00	Flexible Coupling MCV251010 €53.00	General-Purpose Cable 1 m CC16D010B-1 €18.00

● The system configuration shown above is an example. Other combinations are available.

● Pulse Input Type, Standard Type with Electromagnetic Brake

A single-axis system configuration with the **SCX11** controller.

*1 Not supplied

*2 Only for products in which a connection cable is included.

Accessories (Sold separately)



MCV Couplings
→ Page A-482

When extending the distance between the motor and driver without using an accessory cable*2.



(For Motor) (For Electromagnetic Brake)

Connection Cable Sets
Flexible Connection Cable Sets
→ Page A-462

or



(For Motor) (For Electromagnetic Brake)

Extension Cable Sets
Flexible Extension Cable Sets
→ Page A-463

RKII Series

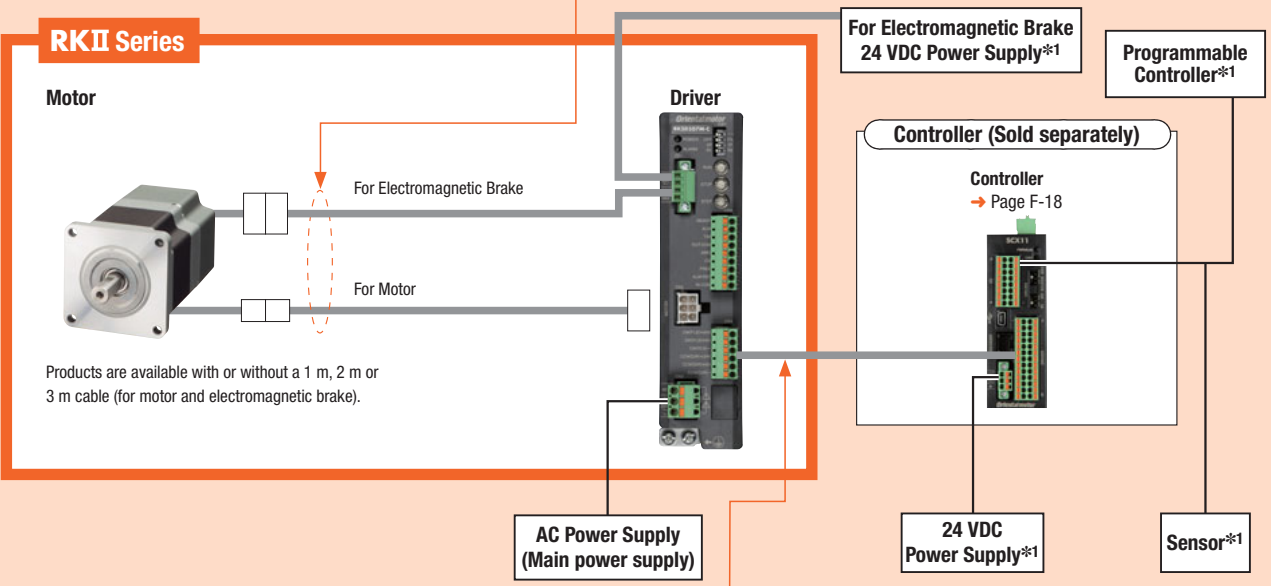

Motor
Products are available with or without a 1 m, 2 m or 3 m cable (for motor and electromagnetic brake).

Driver

Controller (Sold separately)
Controller → Page F-18

AC Power Supply (Main power supply)

24 VDC Power Supply*1

Programmable Controller*1

Sensor*1

Accessories (Sold separately)



Motor Mounting Brackets
→ Page A-490



General-Purpose Cables
→ Page A-464

● Refer to the User Manual for operation procedure of this product. For details, please contact the nearest Oriental Motor sales office or download from the Oriental Motor website.
www.orientalmotor.eu

Overview, Product Series

AC Input Motor & Driver

0.36°/Geared
αSTEP Absolute AZ

0.36°/Geared
αSTEP AR

0.72°/Geared
RKII

DC Input Motor & Driver

0.36°/Geared
αSTEP Absolute AZ

0.36°/Geared
αSTEP AR

1.8°/0.72°/0.36°
CVK

0.72°/0.36°/Geared
CRK

1.8°/Geared
RBK

Motor Only /Driver Only

1.8°/0.9°
PKP/PK

Geared
PKP/PK

0.72°/0.36°
PKP/PK

Driver

Accessories

● Example of System Configuration

RKII Series	Sold Separately			
	Controller	Motor Mounting Bracket	Flexible Coupling	General-Purpose Cable 1 m
RK5566MC-3	SCX11	PAL2P-5	MCV251010	CC16D010B-1
€577.00	€215.00	€13.00	€53.00	€18.00

● The system configuration shown above is an example. Other combinations are available.

Standard Type Frame Size 42 mm, 60 mm

Standard Type with Electromagnetic Brake

Standard Type with Encoder

Specifications



Product Name	Built-in Controller Type Pulse Input Type	RKS543	RKS544	RKS545	RKS564	RKS566	RKS569
		C	C	C	C	C	C
Maximum Holding Torque	N·m	0.14	0.21	0.27	0.52	0.96	1.77
Holding Torque at Motor Standstill	Power ON	0.07	0.10	0.13	0.26	0.48	0.88
	Electromagnetic Brake	0.07	0.10	0.13	0.26	0.48	0.88
Rotor Inertia	J : kg·m ²	30×10 ⁻⁷ [45×10 ⁻⁷]*1 (31×10 ⁻⁷)*2	47×10 ⁻⁷ [62×10 ⁻⁷]*1 (48×10 ⁻⁷)*2	64×10 ⁻⁷ [79×10 ⁻⁷]*1 (65×10 ⁻⁷)*2	160×10 ⁻⁷ [320×10 ⁻⁷]*1 (160×10 ⁻⁷)*2	270×10 ⁻⁷ [430×10 ⁻⁷]*1 (270×10 ⁻⁷)*2	540×10 ⁻⁷ [700×10 ⁻⁷]*1 (540×10 ⁻⁷)*2
	Rated Current	A / Phase 0.35			0.75		
Basic Step Angle		0.72°					
Power Supply Input	Voltage / Frequency	Single-Phase 200-240 VAC -15~+10% 50/60 Hz					
	Input Current	A 1.3	1.2	1.2	2.4	2.4	2.5
Excitation Mode		Microstep					
Control Power Supply*3		24 VDC±5%*5 0.08 A					
Electromagnetic Brake*4	Power Supply Input	24 VDC±5%*5 0.08 A			24 VDC±5%*5 0.25 A		

- For Built-in Controller package, enter **A** (single shaft), **B** (double shaft), **M** (with electromagnetic brake) or **R** (with encoder) where the box □ is located within the product name. For Pulse Input package, enter **A** (single shaft), **B** (double shaft) or **M** (with electromagnetic brake) where the box □ is located within the product name. For encoder type, **2** will be entered where □ is located within the product name.
- For products that include a connection cable, a number indicating the cable length, **1** (1 m), **2** (2 m) or **3** (3 m) is specified where the box ◇ is located in the product name. If no connection cable is included, there will be no "◇" within the product name.
- *1 The values inside the brackets [] represent the specification for the electromagnetic brake product.
- *2 The values inside the brackets () represent the specification for the encoder product.
- *3 For Built-in Controller package, the control power supply is required.
- *4 A separate power supply for electromagnetic brakes is required.
- *5 If the wiring distance between the motor and driver is extended to 15 m or longer by using an accessory cable (sold separately), the 24 VDC±4% specification applies.

Speed – Torque Characteristics (Reference values)

RKS543

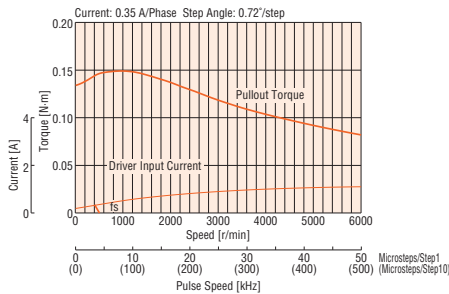

RKS544

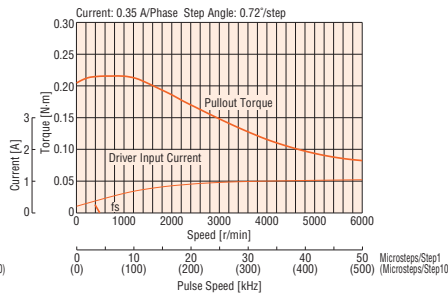

RKS545

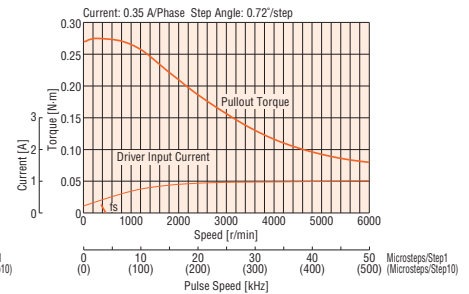

RKS564

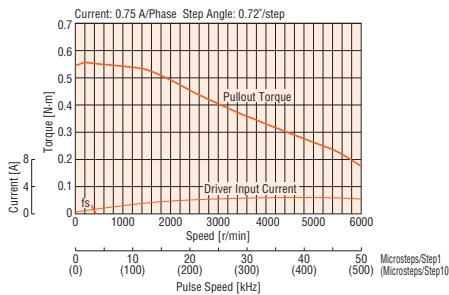

RKS566

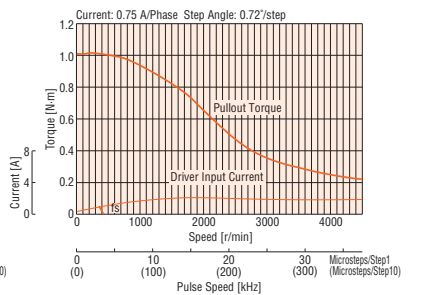

RKS569

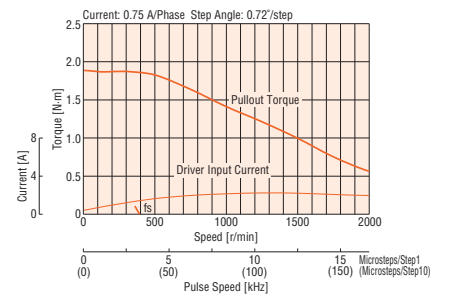

Note

- Data for the speed–torque characteristics is based on Oriental Motor's internal measurement conditions. If the conditions are changed, the characteristics may also change as a result.
- Depending on the driving conditions, a considerable amount of heat may be generated by the motor. Be sure to keep the temperature of the motor case under 100°C. For the Encoder type, in order to protect encoder, be sure to keep the temperature of the motor case under 85°C. (When conforming to the UL or CSA Standards, the temperature of the motor case must be kept at 75°C or less since the motor is recognized as heat-resistant class A.)

Overview,
Product
Series

AC Input
Motor &
Driver

0.36°/Geared
Q_{STEP}
Absolute
AZ

0.36°/Geared
Q_{STEP}
AR

0.72°/Geared
RKII

DC Input
Motor &
Driver

0.36°/Geared
Q_{STEP}
Absolute
AZ

0.36°/Geared
Q_{STEP}
AR

1.8°/0.72°
/0.36°
CVK

0.72°/0.36°
/Geared
CRK

1.8°/Geared
RBK

Motor Only
/Driver Only

1.8°/0.9°
PKP/PK

Geared
PKP/PK

0.72°/0.36°
PKP/PK

Driver

Accessories

Standard Type Frame Size 85 mm

Standard Type with Electromagnetic Brake

Standard Type with Encoder

Specifications



Product Name	Built-in Controller Type Pulse Input Type	RK5596□CD□-◇		RK5599□CD□-◇		RK55913□CD□-◇	
		RK5596□C-◇		RK5599□C-◇		RK55913□C-◇	
Maximum Holding Torque	N-m	2.1		4.1		6.3	
Holding Torque at Motor Standstill	Power ON	1.05		2.05		3.15	
	Electromagnetic Brake	1.05		2.05		3.15	
Rotor Inertia	J : kg·m ²	1100×10 ⁻⁷ [2200×10 ⁻⁷]*1 (1100×10 ⁻⁷)*2		2200×10 ⁻⁷ [3300×10 ⁻⁷]*1 (2200×10 ⁻⁷)*2		3300×10 ⁻⁷ [4400×10 ⁻⁷]*1 (3300×10 ⁻⁷)*2	
Rated Current	A / Phase			0.75			
Basic Step Angle				0.72°			
Power Supply Input	Voltage / Frequency	Single-Phase 200-240 VAC -15~+10% 50/60 Hz					
	Input Current	A	2.1	2.2	2.2		
Excitation Mode		Microstep					
Control Power Supply*3		24 VDC±5% 0.2 A					
Electromagnetic Brake*4	Power Supply Input	24 VDC±5%*5 0.42 A					

- For Built-in Controller package, enter **A** (single shaft), **B** (double shaft), **M** (with electromagnetic brake) or **R** (with encoder) where the box □ is located within the product name.
For Pulse Input package, enter **A** (single shaft), **B** (double shaft) or **M** (with electromagnetic brake) where the box □ is located within the product name.
For encoder type, **2** will be entered where □ is located within the product name.
For products that include a connection cable, a number indicating the cable length, **1** (1 m), **2** (2 m) or **3** (3 m) is specified where the box ◇ is located in the product name.
If no connection cable is included, there will be no "-◇" within the product name.

- *1 The values inside the brackets [] represent the specification for the electromagnetic brake product.
- *2 The values inside the brackets () represent the specification for the encoder product.
- *3 For Built-in Controller package, the control power supply is required.
- *4 A separate power supply for electromagnetic brakes is required.
- *5 If the wiring distance between the motor and driver is extended to 15 m or longer by using an accessory cable (sold separately), the 24 VDC±4% specification applies.

Speed – Torque Characteristics (Reference values)

RK5596

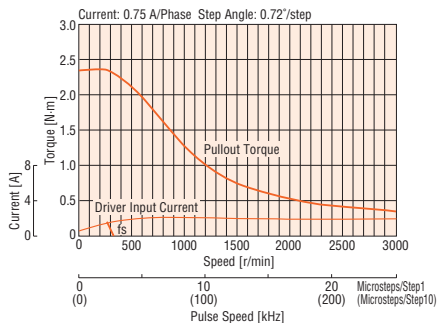

RK5599

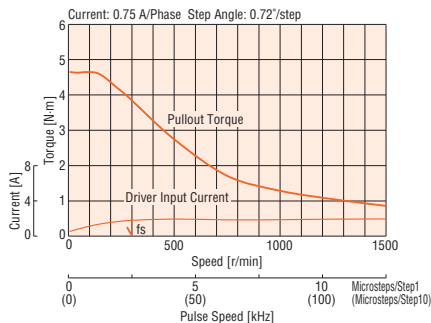

RK55913

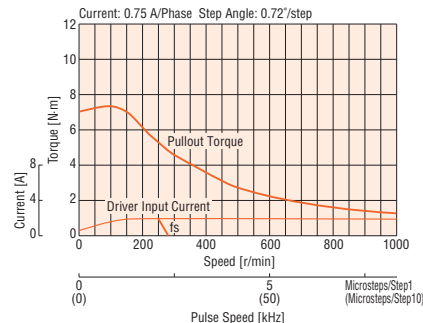

Note

- Data for the speed–torque characteristics is based on Oriental Motor’s internal measurement conditions. If the conditions are changed, the characteristics may also change as a result.
- Depending on the driving conditions, a considerable amount of heat may be generated by the motor. Be sure to keep the temperature of the motor case under 100°C.
For the Encoder type, in order to protect encoder, be sure to keep the temperature of the motor case under 85°C.
(When conforming to the UL or CSA Standards, the temperature of the motor case must be kept at 75°C or less since the motor is recognized as heat-resistant class A.)

TS Geared Type Frame Size 42 mm TS Geared Type with Electromagnetic Brake

Specifications



Product Name	Built-in Controller Type	RKS543□CD-TS3.6-◇	RKS543□CD-TS7.2-◇	RKS543□CD-TS10-◇	RKS543□CD-TS20-◇	RKS543□CD-TS30-◇
	Pulse Input Type	RKS543□C-TS3.6-◇	RKS543□C-TS7.2-◇	RKS543□C-TS10-◇	RKS543□C-TS20-◇	RKS543□C-TS30-◇
Maximum Holding Torque	N·m	0.5	1	1.4	2	2.3
Rotor Inertia	J : kg·m ²	30×10 ⁻⁷ [45×10 ⁻⁷]*1				
Rated Current	A / Phase	0.35				
Basic Step Angle		0.2°	0.1°	0.072°	0.036°	0.024°
Gear Ratio		3.6	7.2	10	20	30
Permissible Torque*	N·m	*	*	*	2	2.3
Maximum Instantaneous Torque*	N·m	*	*	*	*	3
Holding Torque at Power ON	N·m	0.26	0.53	0.74	1.48	2.2
Motor Standstill Electromagnetic Brake	N·m	0.26	0.53	0.74	1.48	2.2
Speed Range	r/min	0~833	0~416	0~300	0~150	0~100
Backlash	arcmin	45 (0.75°)	25 (0.42°)		15 (0.25°)	
Power Supply Input Voltage / Frequency		Single-Phase 200-240 VAC -15~+10% 50/60 Hz				
Power Supply Input Input Current	A	1.3				
Excitation Mode		Microstep				
Control Power Supply*2		24 VDC±5% 0.2 A				
Electromagnetic Brake*3	Power Supply Input	24 VDC±5%*4 0.08 A				

*For the geared motor output torque, refer to the speed-torque characteristics.

● Enter **A** (single shaft), **B** (double shaft) or **M** (with electromagnetic brake) where the box □ is located within the product name.

For products that include a connection cable, a number indicating the cable length, **1** (1 m), **2** (2 m) or **3** (3 m) is specified where the box ◇ is located in the product name.

If no connection cable is included, there will be no "◇" within the product name.

*1 The values inside the brackets [] represent the specification for the electromagnetic brake product.

*2 For Built-in Controller package, the control power supply is required.

*3 A separate power supply for electromagnetic brakes is required.

*4 If the wiring distance between the motor and driver is extended to 15 m or longer by using an accessory cable (sold separately), the 24 VDC±4% specification applies.

Speed – Torque Characteristics (Reference values)

RKS543 Gear Ratio: 3.6

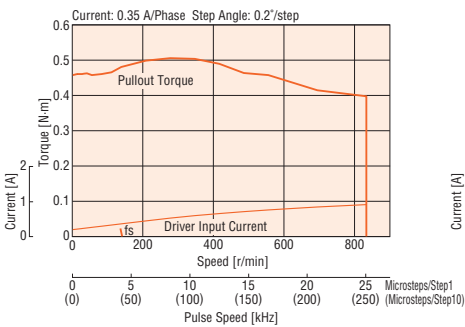

RKS543 Gear Ratio: 7.2

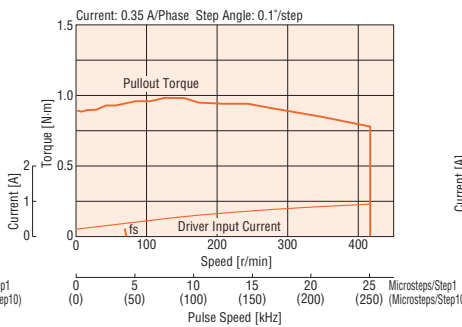

RKS543 Gear Ratio: 10

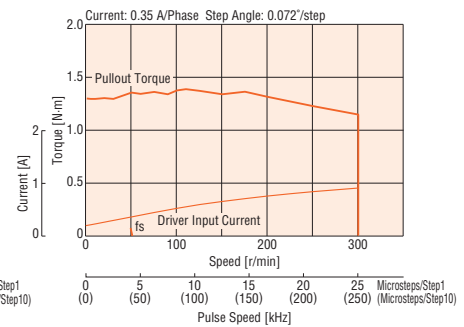

RKS543 Gear Ratio: 20

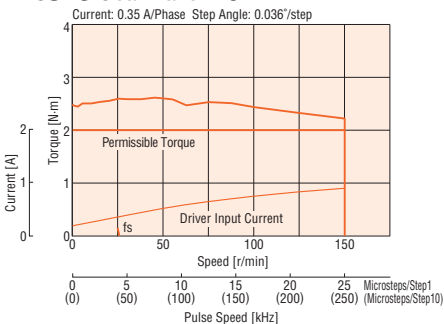

RKS543 Gear Ratio: 30

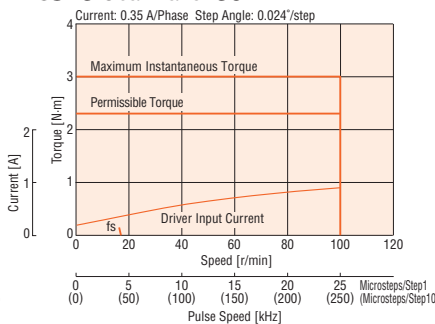

Note

- Data for the speed-torque characteristics is based on Oriental Motor's internal measurement conditions. If the conditions are changed, the characteristics may also change as a result.
- Depending on the driving conditions, a considerable amount of heat may be generated by the motor. Be sure to keep the temperature of the motor case under 100°C. (When conforming to the UL or CSA Standards, the temperature of the motor case must be kept at 75°C or less since the motor is recognized as heat-resistant class A.)

Overview, Product Series

AC Input Motor & Driver

0.36°/Geared
αSTEP
Absolute
AZ

0.36°/Geared
αSTEP
AR

0.72°/Geared
RKII

DC Input Motor & Driver

0.36°/Geared
αSTEP
Absolute
AZ

0.36°/Geared
αSTEP
AR

1.8°/0.72°
/0.36°
CVK

0.72°/0.36°
/Geared
CRK

1.8°/Geared
RBK

Motor Only /Driver Only

1.8°/0.9°
PKP/PK

Geared
PKP/PK

0.72°/0.36°
PKP/PK

Driver

Accessories

TS Geared Type Frame Size 60 mm

TS Geared Type with Electromagnetic Brake



Specifications

Product Name	Built-in Controller Type Pulse Input Type	RKS564□CD-TS3.6-◇	RKS564□CD-TS7.2-◇	RKS564□CD-TS10-◇	RKS564□CD-TS20-◇	RKS564□CD-TS30-◇
		RKS564□C-TS3.6-◇	RKS564□C-TS7.2-◇	RKS564□C-TS10-◇	RKS564□C-TS20-◇	RKS564□C-TS30-◇
Maximum Holding Torque	N·m	1.8	3	4	5	6
Rotor Inertia	J : kg·m ²	160×10 ⁻⁷ [320×10 ⁻⁷]*1				
Rated Current	A / Phase	0.75				
Basic Step Angle		0.2°	0.1°	0.072°	0.036°	0.024°
Gear Ratio		3.6	7.2	10	20	30
Permissible Torque*	N·m	*	3	4	5	6
Maximum Instantaneous Torque*	N·m	*	*	*	8	10
Holding Torque at Power ON	N·m	1	2	2.9	5	6
Motor Standstill Electromagnetic Brake	N·m	1	2	2.9	5	6
Speed Range	r/min	0~833	0~416	0~300	0~150	0~100
Backlash	arcmin	35 (0.59°)	15 (0.25°)		10 (0.17°)	
Power Supply Input Voltage / Frequency		Single-Phase 200-240 VAC -15~+10% 50/60 Hz				
Power Supply Input Input Current	A	2.4				
Excitation Mode		Microstep				
Control Power Supply*2		24 VDC±5% 0.2 A				
Electromagnetic Brake*3 Power Supply Input		24 VDC±5%*4 0.25 A				

*For the geared motor output torque, refer to the speed-torque characteristics.

● Enter **A** (single shaft), **B** (double shaft) or **M** (with electromagnetic brake) where the box □ is located within the product name.

For products that include a connection cable, a number indicating the cable length, **1** (1 m), **2** (2 m) or **3** (3 m) is specified where the box ◇ is located in the product name.

If no connection cable is included, there will be no "◇" within the product name.

*1 The values inside the brackets [] represent the specification for the electromagnetic brake product.

*2 For Built-in Controller package, the control power supply is required.

*3 A separate power supply for electromagnetic brakes is required.

*4 If the wiring distance between the motor and driver is extended to 15 m or longer by using an accessory cable (sold separately), the 24 VDC±4% specification applies.

Speed – Torque Characteristics (Reference values)

RKS564 Gear Ratio: 3.6

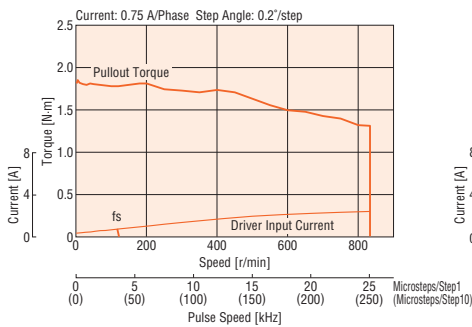

RKS564 Gear Ratio: 7.2

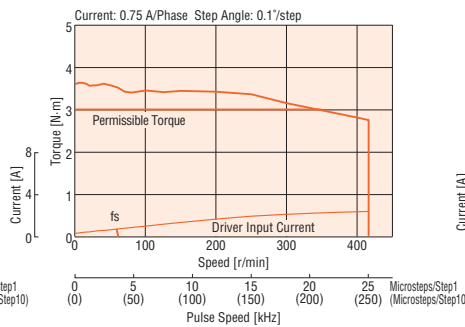

RKS564 Gear Ratio: 10

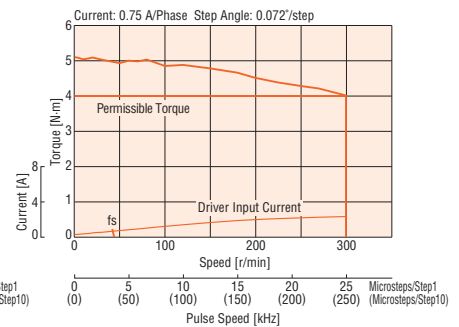

RKS564 Gear Ratio: 20

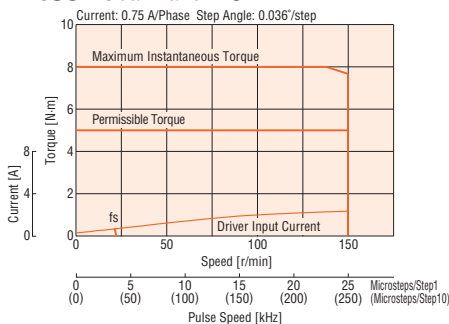

RKS564 Gear Ratio: 30

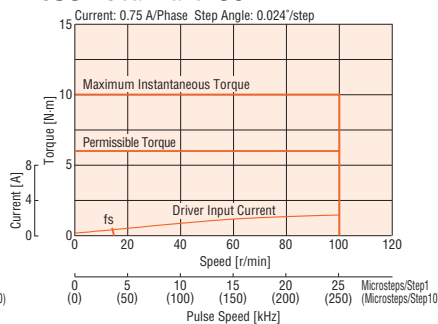

Note

- Data for the speed-torque characteristics is based on Oriental Motor's internal measurement conditions. If the conditions are changed, the characteristics may also change as a result.
- Depending on the driving conditions, a considerable amount of heat may be generated by the motor. Be sure to keep the temperature of the motor case under 100°C. (When conforming to the UL or CSA Standards, the temperature of the motor case must be kept at 75°C or less since the motor is recognized as heat-resistant class A.)

TS Geared Type Frame Size 90 mm TS Geared Type with Electromagnetic Brake

Specifications



Product Name	Built-in Controller Type Pulse Input Type	RK5596□CD-TS3.6-◇	RK5596□CD-TS7.2-◇	RK5596□CD-TS10-◇	RK5596□CD-TS20-◇	RK5596□CD-TS30-◇
		RK5596□C-TS3.6-◇	RK5596□C-TS7.2-◇	RK5596□C-TS10-◇	RK5596□C-TS20-◇	RK5596□C-TS30-◇
Maximum Holding Torque	N·m	6	10	14	20	25
Rotor Inertia	J : kg·m ²	1100×10 ⁻⁷ [2200×10 ⁻⁷]*1				
Rated Current	A / Phase	0.75				
Basic Step Angle		0.2°	0.1°	0.072°	0.036°	0.024°
Gear Ratio		3.6	7.2	10	20	30
Permissible Torque*	N·m	6	10	*	20	25
Maximum Instantaneous Torque*	N·m	*	15	*	*	*
Holding Torque at Power ON	N·m	4.5	9	7.4	14.8	22
Motor Standstill Electromagnetic Brake	N·m	4.5	9	7.4	14.8	22
Speed Range	r/min	0~833	0~416	0~300	0~150	0~100
Backlash	arcmin	25 (0.42°)	15 (0.25°)		10 (0.17°)	
Power Supply Input Voltage / Frequency		Single-Phase 200-240 VAC -15~+10% 50/60 Hz				
Power Supply Input Input Current	A	2.1		3.0		
Excitation Mode		Microstep				
Control Power Supply*2		24 VDC±5% 0.2 A				
Electromagnetic Brake*3	Power Supply Input	24 VDC±5%*4 0.42 A				

- *For the geared motor output torque, refer to the speed-torque characteristics.
- Enter **A** (single shaft), **B** (double shaft) or **M** (with electromagnetic brake) where the box □ is located within the product name.
For products that include a connection cable, a number indicating the cable length, **1** (1 m), **2** (2 m) or **3** (3 m) is specified where the box ◇ is located in the product name.
If no connection cable is included, there will be no "◇" within the product name.
- *1 The values inside the brackets [] represent the specification for the electromagnetic brake product.
- *2 For Built-in Controller package, the control power supply is required.
- *3 A separate power supply for electromagnetic brakes is required.
- *4 If the wiring distance between the motor and driver is extended to 15 m or longer by using an accessory cable (sold separately), the 24 VDC±4% specification applies.

Speed – Torque Characteristics (Reference values)

RK5596 Gear Ratio: 3.6

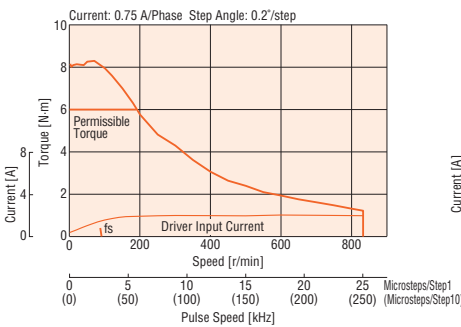

RK5596 Gear Ratio: 7.2

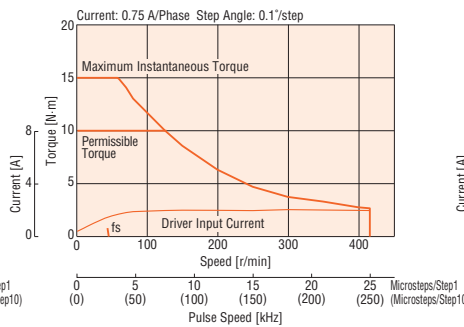

RK5596 Gear Ratio: 10

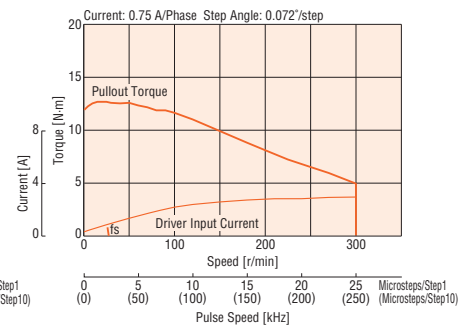

RK5596 Gear Ratio: 20

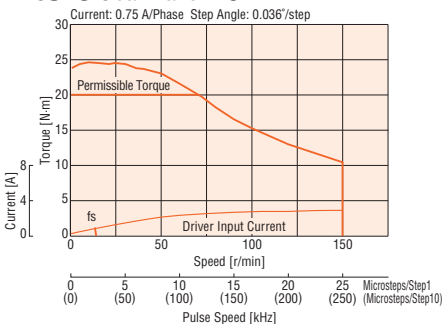

RK5596 Gear Ratio: 30

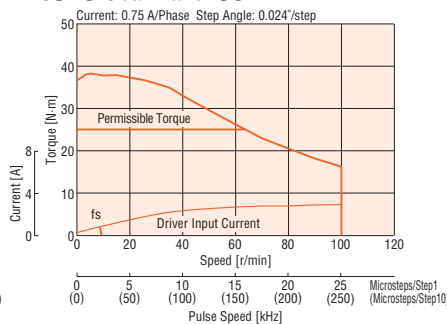

Note

- Data for the speed-torque characteristics is based on Oriental Motor's internal measurement conditions. If the conditions are changed, the characteristics may also change as a result.
- Depending on the driving conditions, a considerable amount of heat may be generated by the motor. Be sure to keep the temperature of the motor case under 100°C.
(When conforming to the UL or CSA Standards, the temperature of the motor case must be kept at 75°C or less since the motor is recognized as heat-resistant class A.)

Overview,
Product
Series

AC Input
Motor &
Driver

0.36°/Geared
AZ
Absolute
AZ

0.36°/Geared
AR
AZ

0.72°/Geared
RKII

DC Input
Motor &
Driver

0.36°/Geared
AZ
Absolute
AZ

0.36°/Geared
AR
AZ

1.8°/0.72°
/0.36°
CVK

0.72°/0.36°
/Geared
CRK

1.8°/Geared
RBK

Motor Only
/Driver Only

1.8°/0.9°
PKP/PK

Geared
PKP/PK

0.72°/0.36°
PKP/PK

Driver

Accessories

PS Geared Type Frame Size 42 mm

PS Geared Type with Electromagnetic Brake

Specifications



Product Name	Built-in Controller Type	RKS545□CD-PS5-◇	RKS545□CD-PS7.2-◇	RKS545□CD-PS10-◇	RKS543□CD-PS25-◇	RKS543□CD-PS36-◇	RKS543□CD-PS50-◇
	Pulse Input Type	RKS545□C-PS5-◇	RKS545□C-PS7.2-◇	RKS545□C-PS10-◇	RKS543□C-PS25-◇	RKS543□C-PS36-◇	RKS543□C-PS50-◇
Maximum Holding Torque	N·m	1	1.5	2.5	3		
Rotor Inertia	J : kg·m ²	64 × 10 ⁻⁷ [79 × 10 ⁻⁷]*1			30 × 10 ⁻⁷ [45 × 10 ⁻⁷]*1		
Rated Current	A / Phase	0.35					
Basic Step Angle		0.144°	0.1°	0.072°	0.0288°	0.02°	0.0144°
Gear Ratio		5	7.2	10	25	36	50
Permissible Torque*	N·m	1	1.5	2.5	3		
Maximum Instantaneous Torque*	N·m	*	*	2	*	*	6
Holding Torque at Power ON	N·m	0.74	1.07	1.49	1.85	2.6	3
Motor Standstill Electromagnetic Brake	N·m	0.74	1.07	1.49	1.85	2.6	3
Speed Range	r/min	0~600	0~416	0~300	0~120	0~83	0~60
Backlash	arcmin	25 (0.42°)					
Power Supply Input Voltage / Frequency		Single-Phase 200-240 VAC -15~+10% 50/60 Hz					
Power Supply Input Input Current	A	1.2			1.3		
Excitation Mode		Microstep					
Control Power Supply*2		24 VDC ± 5% 0.2 A					
Electromagnetic Brake*3	Power Supply Input	24 VDC ± 5%*4 0.08 A					

*For the geared motor output torque, refer to the speed-torque characteristics.

● Enter **A** (single shaft), **B** (double shaft) or **M** (with electromagnetic brake) where the box □ is located within the product name.

For products that include a connection cable, a number indicating the cable length, **1** (1 m), **2** (2 m) or **3** (3 m) is specified where the box ◇ is located in the product name.

If no connection cable is included, there will be no "◇" within the product name.

● 1 The values inside the brackets [] represent the specification for the electromagnetic brake product.

*2 For Built-in Controller package, the control power supply is required.

*3 A separate power supply for electromagnetic brakes is required.

*4 If the wiring distance between the motor and driver is extended to 15 m or longer by using an accessory cable (sold separately), the 24 VDC ± 4% specification applies.

Speed – Torque Characteristics (Reference values)

RKS545 Gear Ratio: 5

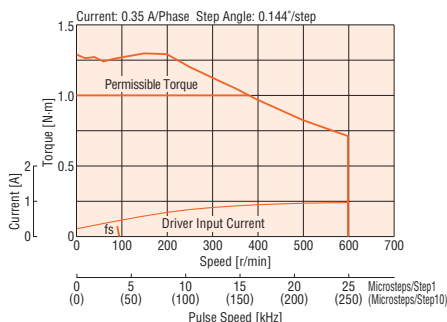

RKS545 Gear Ratio: 7.2

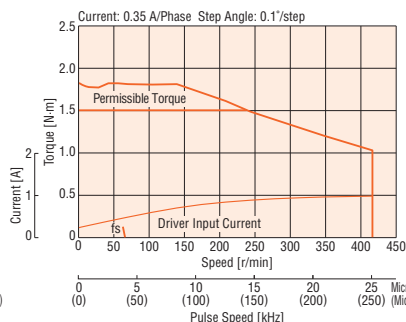

RKS545 Gear Ratio: 10

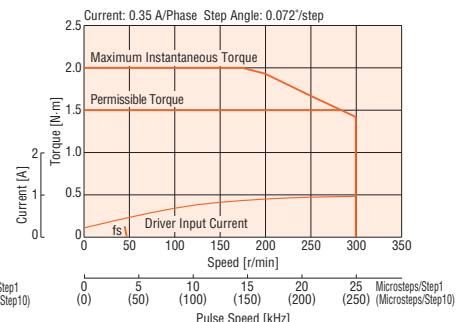

RKS543 Gear Ratio: 25

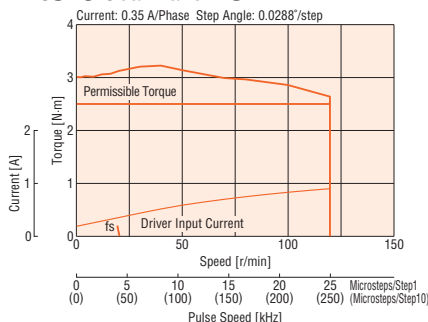

RKS543 Gear Ratio: 36

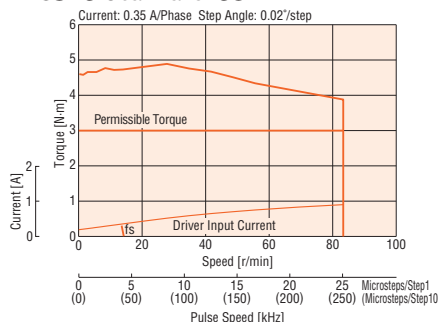

RKS543 Gear Ratio: 50

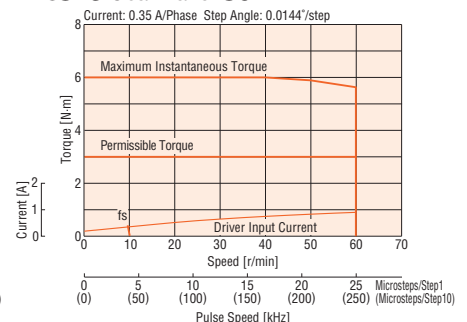

Note

● Data for the speed-torque characteristics is based on Oriental Motor's internal measurement conditions. If the conditions are changed, the characteristics may also change as a result.

● Depending on the driving conditions, a considerable amount of heat may be generated by the motor. Be sure to keep the temperature of the motor case under 100°C. (When conforming to the UL or CSA Standards, the temperature of the motor case must be kept at 75°C or less since the motor is recognized as heat-resistant class A.)

PS Geared Type Frame Size 60 mm PS Geared Type with Electromagnetic Brake

Specifications



Product Name	Built-in Controller Type		RKS566□CD-PS5-◇	RKS566□CD-PS7.2-◇	RKS566□CD-PS10-◇	RKS564□CD-PS25-◇	RKS564□CD-PS36-◇	RKS564□CD-PS50-◇
	Pulse Input Type		RKS566□C-PS5-◇	RKS566□C-PS7.2-◇	RKS566□C-PS10-◇	RKS564□C-PS25-◇	RKS564□C-PS36-◇	RKS564□C-PS50-◇
Maximum Holding Torque	N·m		3.5	4	5	8		
Rotor Inertia	J : kg·m ²		270×10 ⁻⁷ [430×10 ⁻⁷]*1			160×10 ⁻⁷ [320×10 ⁻⁷]*1		
Rated Current	A / Phase		0.75					
Basic Step Angle			0.144°	0.1°	0.072°	0.0288°	0.02°	0.0144°
Gear Ratio			5	7.2	10	25	36	50
Permissible Torque*	N·m		3.5	4	5	8		
Maximum Instantaneous Torque*	N·m		*	*	*	*	*	20
Holding Torque at Motor Standstill	Power ON	N·m	2.7	3.9	5	7.2	8	
	Electromagnetic Brake	N·m	2.7	3.9	5	7.2	8	
Speed Range	r/min		0~600	0~416	0~300	0~120	0~83	0~60
Backlash	arcmin		7 (0.12°)			9 (0.15°)		
Power Supply Input	Voltage / Frequency		Single-Phase 200-240 VAC -15~+10% 50/60 Hz					
	Input Current		2.4			2.4		
Excitation Mode			Microstep					
Control Power Supply*2			24 VDC±5% 0.2 A					
Electromagnetic Brake*3	Power Supply Input		24 VDC±5%*4 0.25 A					

- *For the geared motor output torque, refer to the speed-torque characteristics.
- Enter **A** (single shaft), **B** (double shaft) or **M** (with electromagnetic brake) where the box □ is located within the product name.
For products that include a connection cable, a number indicating the cable length, **1** (1 m), **2** (2 m) or **3** (3 m) is specified where the box ◇ is located in the product name.
If no connection cable is included, there will be no "◇" within the product name.
- *1 The values inside the brackets [] represent the specification for the electromagnetic brake product.
- *2 For Built-in Controller package, the control power supply is required.
- *3 A separate power supply for electromagnetic brakes is required.
- *4 If the wiring distance between the motor and driver is extended to 15 m or longer by using an accessory cable (sold separately), the 24 VDC±4% specification applies.

Speed – Torque Characteristics (Reference values)

RKS566 Gear Ratio: 5

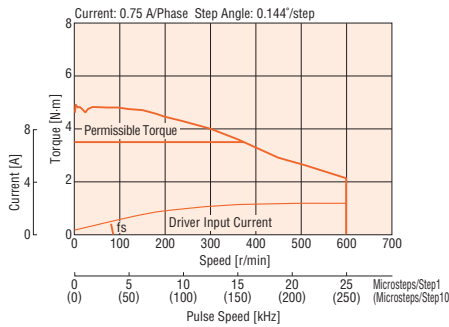

RKS566 Gear Ratio: 7.2

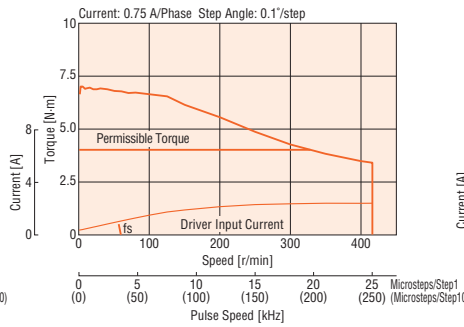

RKS566 Gear Ratio: 10

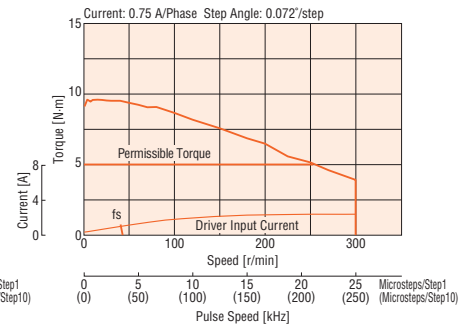

RKS564 Gear Ratio: 25

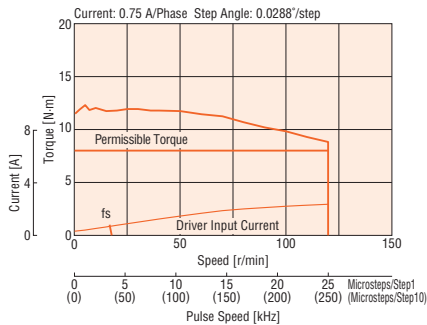

RKS564 Gear Ratio: 36

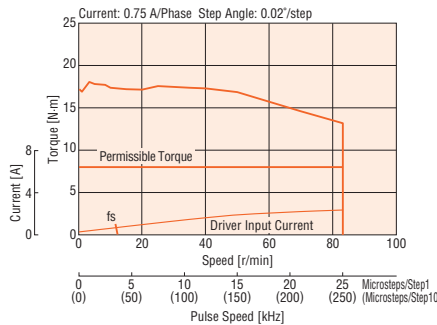

RKS564 Gear Ratio: 50

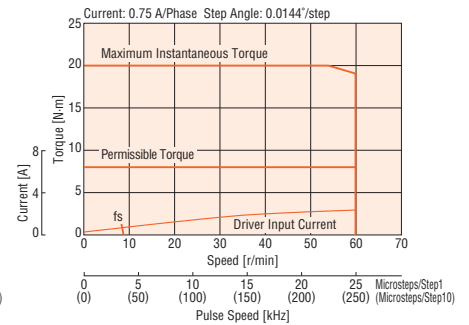

Note

- Data for the speed-torque characteristics is based on Oriental Motor's internal measurement conditions. If the conditions are changed, the characteristics may also change as a result.
- Depending on the driving conditions, a considerable amount of heat may be generated by the motor. Be sure to keep the temperature of the motor case under 100°C.
(When conforming to the UL or CSA Standards, the temperature of the motor case must be kept at 75°C or less since the motor is recognized as heat-resistant class A.)

Overview, Product Series

AC Input Motor & Driver

0.36°/Geared
AZSTEP
Absolute
AZ

0.36°/Geared
AZSTEP
AR

0.72°/Geared
RKII

DC Input Motor & Driver

0.36°/Geared
AZSTEP
Absolute
AZ

0.36°/Geared
AZSTEP
AR

1.8°/0.72°
/0.36°
CVK

0.72°/0.36°
/Geared
CRK

1.8°/Geared
RBK

Motor Only /Driver Only

1.8°/0.9°
PKP/PK

Geared
PKP/PK

0.72°/0.36°
PKP/PK

Driver

Accessories

PS Geared Type Frame Size 90 mm

PS Geared Type with Electromagnetic Brake

Specifications



Product Name	Built-in Controller Type Pulse Input Type	RKS599□CD-PS5-◇	RKS599□CD-PS7.2-◇	RKS599□CD-PS10-◇	RKS596□CD-PS25-◇	RKS596□CD-PS36-◇	RKS596□CD-PS50-◇	
		RKS599□C-PS5-◇	RKS599□C-PS7.2-◇	RKS599□C-PS10-◇	RKS596□C-PS25-◇	RKS596□C-PS36-◇	RKS596□C-PS50-◇	
Maximum Holding Torque	N·m	14	20		36	37		
Rotor Inertia	J : kg·m ²	2200×10 ⁻⁷ [3300×10 ⁻⁷]*1			1100×10 ⁻⁷ [2200×10 ⁻⁷]*1			
Rated Current	A / Phase	0.75						
Basic Step Angle		0.144°	0.1°	0.072°	0.0288°	0.02°	0.0144°	
Gear Ratio		5	7.2	10	25	36	50	
Permissible Torque*	N·m	14	20		*	37		
Maximum Instantaneous Torque*	N·m	*	*	35	*	*	60	
Holding Torque at	Power ON	N·m	12.5	18	20	18.5	26	37
Motor Standstill	Electromagnetic Brake	N·m	12.5	18	20	18.5	26	37
Speed Range	r/min	0~300	0~208		0~150	0~120	0~83	0~60
Backlash	arcmin	7 (0.12°)				9 (0.15°)		
Power Supply Input	Voltage / Frequency	Single-Phase 200-240 VAC -15~+10% 50/60 Hz						
	Input Current	A	2.2			3.0		
Excitation Mode		Microstep						
Control Power Supply*2		24 VDC±5% 0.2 A						
Electromagnetic Brake*3	Power Supply Input	24 VDC±5%*4 0.42 A						

*For the geared motor output torque, refer to the speed-torque characteristics.

● Enter **A** (single shaft), **B** (double shaft) or **M** (with electromagnetic brake) where the box □ is located within the product name.

For products that include a connection cable, a number indicating the cable length, **1** (1 m), **2** (2 m) or **3** (3 m) is specified where the box ◇ is located in the product name.

If no connection cable is included, there will be no "◇" within the product name.

*1 The values inside the brackets [] represent the specification for the electromagnetic brake product.

*2 For Built-in Controller package, the control power supply is required.

*3 A separate power supply for electromagnetic brakes is required.

*4 If the wiring distance between the motor and driver is extended to 15 m or longer by using an accessory cable (sold separately), the 24 VDC±4% specification applies.

Speed – Torque Characteristics (Reference values)

RKS599 Gear Ratio: 5

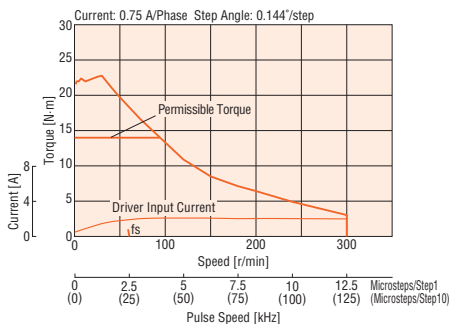

RKS599 Gear Ratio: 7.2

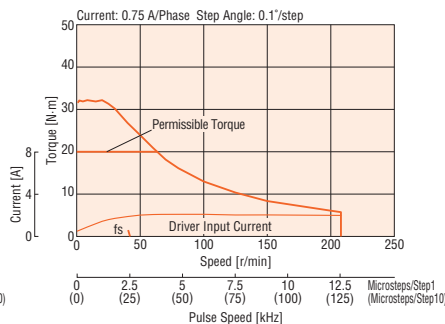

RKS599 Gear Ratio: 10

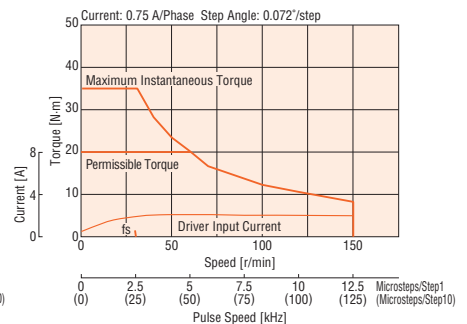

RKS596 Gear Ratio: 25

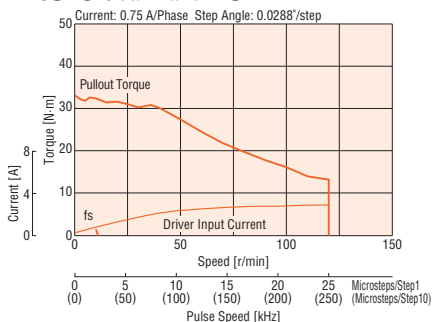

RKS596 Gear Ratio: 36

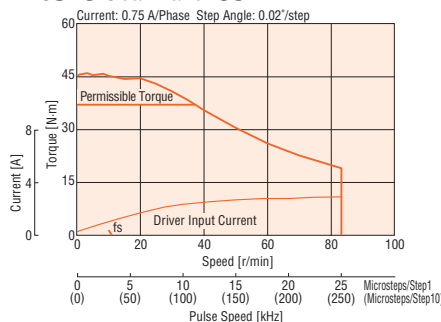

RKS596 Gear Ratio: 50

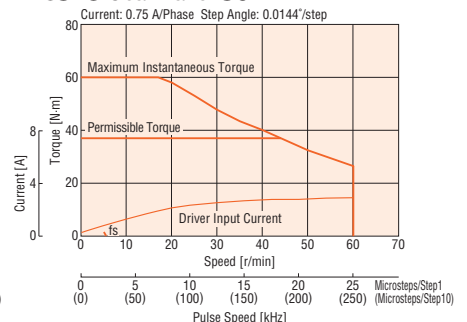

Note

● Data for the speed-torque characteristics is based on Oriental Motor's internal measurement conditions. If the conditions are changed, the characteristics may also change as a result.

● Depending on the driving conditions, a considerable amount of heat may be generated by the motor. Be sure to keep the temperature of the motor case under 100°C. (When conforming to the UL or CSA Standards, the temperature of the motor case must be kept at 75°C or less since the motor is recognized as heat-resistant class A.)

Harmonic Geared Type Frame Size 42 mm, 60 mm, 90 mm Harmonic Geared Type with Electromagnetic Brake

Specifications



Product Name	Built-in Controller Type Pulse Input Type	RKS543	RKS543	RKS564	RKS564	RKS596	RKS596
		CD-HS50	CD-HS100	CD-HS50	CD-HS100	CD-HS50	CD-HS100
Maximum Holding Torque	N·m	3.5	5	7	10	33	52
Rotor Inertia	J : kg·m ²	47×10^{-7} [62×10^{-7}]*1		195×10^{-7} [355×10^{-7}]*1		1300×10^{-7} [2400×10^{-7}]*1	
Rated Current	A / Phase	0.35		0.75		0.75	
Basic Step Angle		0.0144°	0.072°	0.0144°	0.0072°	0.0144°	0.0072°
Gear Ratio		50	100	50	100	50	100
Permissible Torque		3.5	5	7	10	33	52
Maximum Instantaneous Torque*	N·m	*	11	*	36	*	107
Holding Torque at Motor Standstill	Power ON	3.5	5	7	10	33	52
	Electromagnetic Brake	3.5	5	7	10	33	52
Speed Range	r/min	0~70	0~35	0~70	0~35	0~70	0~35
Lost Motion (Load Torque)	arcmin	1.5 maximum (±0.16 N·m)	1.5 maximum (±0.20 N·m)	0.7 maximum (±0.28 N·m)	0.7 maximum (±0.39 N·m)	0.7 maximum (±1.2 N·m)	0.7 maximum (±1.2 N·m)
Power Supply Input	Voltage / Frequency	Single-Phase 200-240 VAC -15~+10% 50/60 Hz					
	Input Current	1.3		2.4		3.0	
Excitation Mode		Microstep					
Control Power Supply*2		24 VDC ± 5% 0.2 A					
Electromagnetic Brake*3	Power Supply Input	24 VDC ± 5%*4 0.08 A		24 VDC ± 5%*4 0.25 A		24 VDC ± 5%*4 0.42 A	

- *For the geared motor output torque, refer to the speed-torque characteristics.
- Enter **A** (single shaft), **B** (double shaft) or **M** (with electromagnetic brake) where the box □ is located within the product name.
For products that include a connection cable, a number indicating the cable length, **1** (1 m), **2** (2 m) or **3** (3 m) is specified where the box ◇ is located in the product name.
If no connection cable is included, there will be no "◇" within the product name.
- *1 The values inside the brackets [] represent the specification for the electromagnetic brake product.
- *2 For Built-in Controller package, the control power supply is required.
- *3 A separate power supply for electromagnetic brakes is required.
- *4 If the wiring distance between the motor and driver is extended to 15 m or longer by using an accessory cable (sold separately), the 24 VDC ± 4% specification applies.

Note

- The rotor inertia represents a sum of the inertia of the harmonic gear converted to a motor shaft value, and the rotor inertia.

Speed – Torque Characteristics (Reference values)

RKS543 Gear Ratio: 50

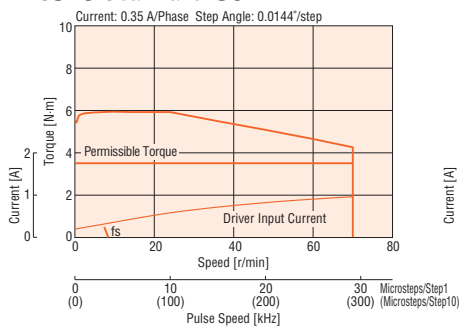

RKS564 Gear Ratio: 50

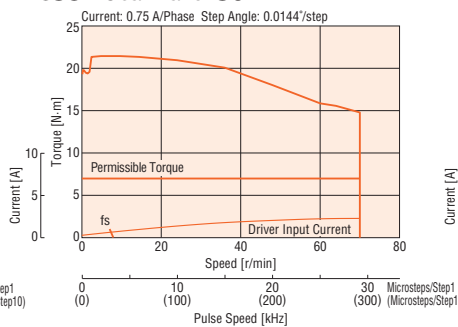

RKS596 Gear Ratio: 50

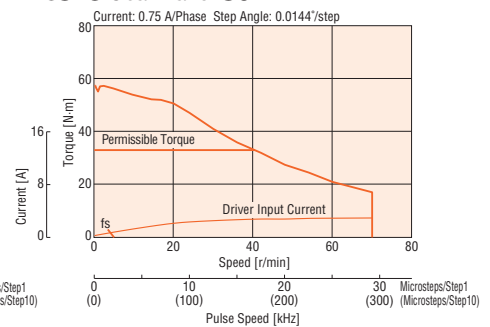

RKS543 Gear Ratio: 100

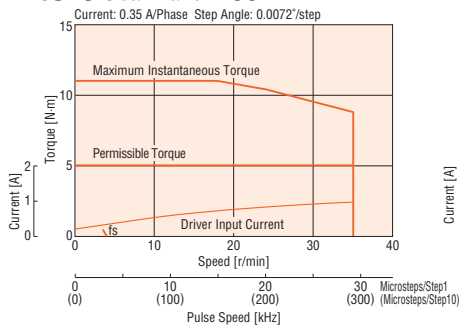

RKS564 Gear Ratio: 100

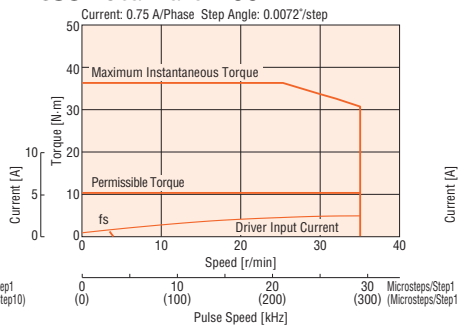

RKS596 Gear Ratio: 100

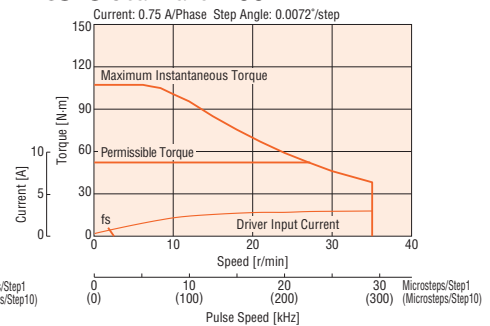

Note

- Data for the speed-torque characteristics is based on Oriental Motor's internal measurement conditions. If the conditions are changed, the characteristics may also change as a result.
- Depending on the driving conditions, a considerable amount of heat may be generated by the motor. Be sure to keep the temperature of the motor case under 100°C.
(When conforming to the UL or CSA Standards, the temperature of the motor case must be kept at 75°C or less since the motor is recognized as heat-resistant class A.)

Overview,
Product
Series

AC Input
Motor &
Driver

0.36°/Geared
αSTEP
Absolute
AZ

0.36°/Geared
αSTEP
AR

0.72°/Geared
RKII

DC Input
Motor &
Driver

0.36°/Geared
αSTEP
Absolute
AZ

0.36°/Geared
αSTEP
AR

1.8°/0.72°
/0.36°
CVK

0.72°/0.36°
/Geared
CRK

1.8°/Geared
RBK

Motor Only
/Driver Only

1.8°/0.9°
PKP/PK

Geared
PKP/PK

0.72°/0.36°
PKP/PK

Driver

Accessories

Driver Specifications

	Built-in Controller type	Pulse Input Type
Maximum Input Pulse Frequency	–	Line Driver Output from controller: 500 kHz (at 50% duty) Open-collector Output from controller: 250 kHz (at 50% duty) Negative Logic Pulse Input
Input Signal	Photocoupler input Input signal voltage: 11.4 VDC~26.4 VDC	Photocoupler Input, Input Signal Voltage: 11.4 VDC~26.4 VDC (AWO, CS, FREE, ALM-RST) Photocoupler Input, Input Signal Voltage: 3 VDC~5.25 VDC (CW (PLS) +5 V, CCW (DIR) +5 V) Photocoupler Input, Input Signal Voltage: 21.6 VDC~26.4 VDC (CW (PLS) +24 V, CCW (DIR) +24 V)
Output Signal	Photocoupler - Open-collector output External use condition: 30 VDC maximum, 10 mA maximum	Photocoupler - Open-collector output External use condition: 30 VDC maximum, 10 mA maximum (READY, ALM, TIM)
Number of Positioning Program	64	–
Positioning Operation	One-shot operation, Linked operation, Linked operation 2, Sequential mode, Direct mode	–
Other Operation	Continuous Operation, JOG Operation, Return-To-Home Operation, Test Operation	–
Control Module OPX-2A	○	–
Data Setting Software MEXE02	○	–

Built-in Controller Type RS-485 Communication Specifications

Protocol	Modbus RTU mode
Electrical Characteristics	EIA-485 compliance Straight Cable Use shielded twisted-pair wire (TIA/EIA-568B CAT5e or greater recommended). The maximum total extension length is 50 m.
Communication Mode	Half-duplex communication Asynchronous mode (data: 8-bit, stop bit: 1-bit/2-bit, parity: none/odd/even)
Baud Rate	9600 bps/19200 bps/38400 bps/57600 bps/115200 bps
Connection Type	Up to 31 units can be connected to one programmable controller (master equipment).

General Specifications

	Motor	Driver	
		Built-in Controller Type	Pulse Input Type
Thermal Class	130 (B) [UL 105 (A) certified]	–	
Insulation Resistance	100 MΩ or more when 500 VDC megger is applied between the following places: · Case – Motor windings · Case – Electromagnetic brake windings*1	100 MΩ or more when 500 VDC megger is applied between the following places: · PE terminal – Power supply terminal · Signal I/O terminal – Power supply terminal	
Dielectric Strength	Sufficient to withstand the following for 1 minute: · Case – Motor windings 1.5 kVAC 50 Hz or 60 Hz · Case – Electromagnetic brake windings*1 1.5 kVAC 50 Hz or 60 Hz	Sufficient to withstand the following for 1 minute: · PE terminal – Power supply terminal 1.5 kVAC 50 Hz or 60 Hz · Signal I/O terminal – Power supply terminal 1.8 kVAC 50 Hz or 60 Hz	· PE terminal – Power supply terminal 1.8 kVAC 50 Hz or 60 Hz · Signal I/O terminal – Power supply terminal 1.9 kVAC 50 Hz or 60 Hz
Operating Environment (In Operation)	Ambient Temperature	–10~+50°C (non-freezing): Standard Type, TS and PS Geared Type 0~+50°C (non-freezing): Product with Encoder 0~+40°C (non-freezing): Harmonic geared type	
	Ambient Humidity	85% or less (non-condensing)	
	Atmosphere	No corrosive gases, dust. Avoid contact with water or oil.	
Temperature Rise	Temperature rise of the windings are 80°C or less. Measured at rated current, at standstill, five phases energized measured (by the resistance change method).	–	
Degree of Protection	IP20	IP10	IP20
Stop Position Accuracy*3	±3 arcmin (±0.05°)		
Shaft Runout	0.05 T.I.R mm*4	–	
Radial Play*5	0.025 mm Max. Load 5 N	–	
Axial Play*6	0.075 mm Max. Load 10 N	–	
Concentricity	0.075 T.I.R mm*4	–	
Perpendicularity	0.075 T.I.R mm*4	–	

*1 Only for products with an electromagnetic brake.

*2 When attaching a heat sink 200 mm × 200 mm × 2 mm, made from aluminum plate or higher.

*3 This value is measured at step angle 0.72°, under no load. (The value changes depends on the size of the load.)

*4 T.I.R. (Total Indicator Reading): The total dial gauge reading when the measurement section is rotated one revolution centered on the reference axis center.

*5 Radial Play: Displacement in shaft position in the radial direction, when a 5 N load is applied in the vertical direction to the tip of the motor's shaft.

*6 Axial Play: Displacement in shaft position in the axial direction, when a 10 N load is applied to the motor's shaft in the axial direction.

Note

● Do not measure insulation resistance or perform the dielectric strength test while the motor and driver are connected.

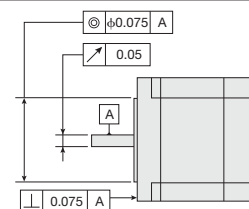

Encoder Specifications

Resolution	500 P/R
Output Mode	Incremental
Output Signal	3 channels
Output Circuit Type	Line Driver

Permissible Radial Load and Permissible Axial Load

→ Page A-17

Dimensions Unit = mm

● Motors

◇ Standard Type

Frame Size 42 mm

Product Name		Motor Product Name	L1	L2	Mass kg
Built-in Controller	Pulse Input				
RKS543ACD ◇	RKS543AC ◇	PKE543AC	34	-	0.26
RKS543BCD ◇	RKS543BC ◇	PKE543BC		49	
RKS544ACD ◇	RKS544AC ◇	PKE544AC	40	-	0.32
RKS544BCD ◇	RKS544BC ◇	PKE544BC		55	
RKS545ACD ◇	RKS545AC ◇	PKE545AC	46	-	0.38
RKS545BCD ◇	RKS545BC ◇	PKE545BC		61	

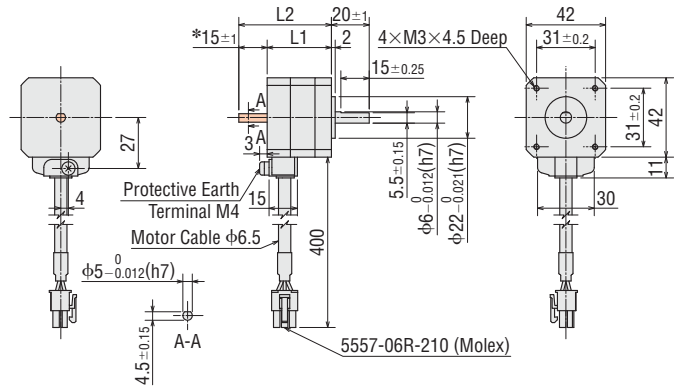

*The length of the shaft flat on the double shaft model is 15±0.25.

Frame Size 60 mm

Product Name		Motor Product Name	L1	L2	Mass kg
Built-in Controller	Pulse Input				
RKS564ACD ◇	RKS564AC ◇	PKE564AC	48.5	-	0.7
RKS564BCD ◇	RKS564BC ◇	PKE564BC		69.5	
RKS566ACD ◇	RKS566AC ◇	PKE566AC	59.5	-	0.9
RKS566BCD ◇	RKS566BC ◇	PKE566BC		80.5	
RKS569ACD ◇	RKS569AC ◇	PKE569AC	89	-	1.4
RKS569BCD ◇	RKS569BC ◇	PKE569BC		110	

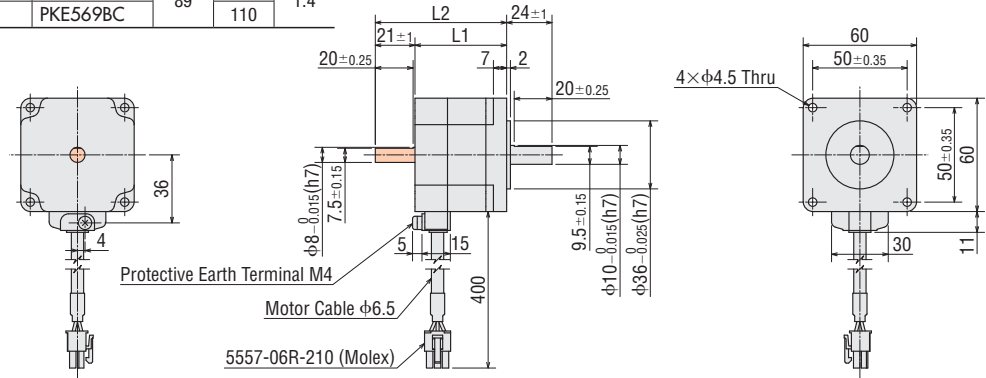

Frame Size 85 mm

Product Name		Motor Product Name	L1	L2	Mass kg
Built-in Controller	Pulse Input				
RKS596ACD ◇	RKS596AC ◇	PKE596AC	68	-	1.9
RKS596BCD ◇	RKS596BC ◇	PKE596BC		100	
RKS599ACD ◇	RKS599AC ◇	PKE599AC	98	-	3.0
RKS599BCD ◇	RKS599BC ◇	PKE599BC		130	
RKS5913ACD ◇	RKS5913AC ◇	PKE5913AC	128	-	4.1
RKS5913BCD ◇	RKS5913BC ◇	PKE5913BC		160	

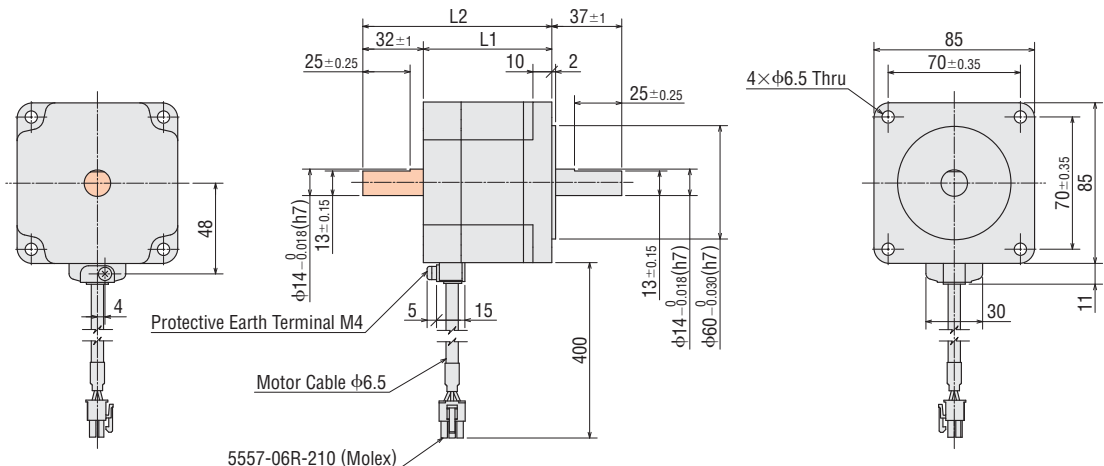

- For products that include a connection cable, a number indicating the cable length, **1** (1 m), **2** (2 m) or **3** (3 m) is specified where the box ◇ is located in the product name. If no connection cable is included, there will be no "◇" within the product name.
- These dimensions are for double shaft motors. For single shaft motors, ignore the areas.

Overview, Product Series

AC Input Motor & Driver

0.36°/Geared
αSTEP Absolute AZ

0.36°/Geared
αSTEP AR

0.72°/Geared
RKII

DC Input Motor & Driver

0.36°/Geared
αSTEP Absolute AZ

0.36°/Geared
αSTEP AR

1.8°/0.72°/0.36°
CVK

0.72°/0.36°/Geared
CRK

1.8°/Geared
RBK

Motor Only /Driver Only

1.8°/0.9°
PKP/PK

Geared
PKP/PK

0.72°/0.36°
PKP/PK

Driver

Accessories

◇ Standard Type with Electromagnetic Brake

Frame Size 42 mm

Product Name		Motor Product Name	L	Mass kg
Built-in Controller	Pulse Input			
RKS543MCD-◇	RKS543MC-◇	PKE543MC	64	0.40
RKS544MCD-◇	RKS544MC-◇	PKE544MC	70	0.46
RKS545MCD-◇	RKS545MC-◇	PKE545MC	75	0.52

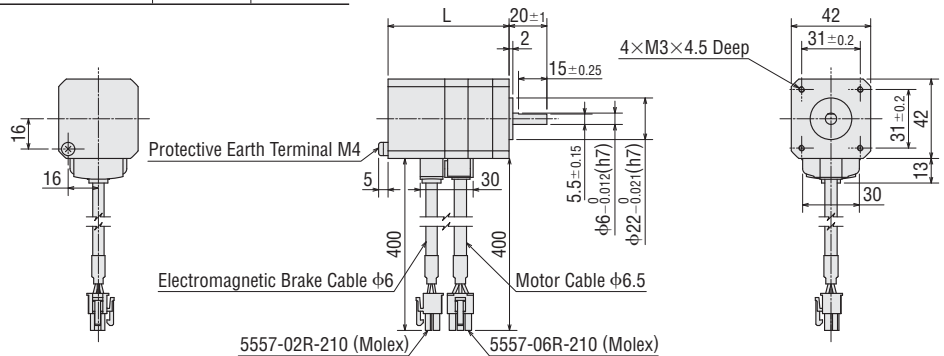

Frame Size 60 mm

Product Name		Motor Product Name	L	Mass kg
Built-in Controller	Pulse Input			
RKS564MCD-◇	RKS564MC-◇	PKE564MC	83.5	1.0
RKS566MCD-◇	RKS566MC-◇	PKE566MC	94.5	1.2
RKS569MCD-◇	RKS569MC-◇	PKE569MC	124	1.7

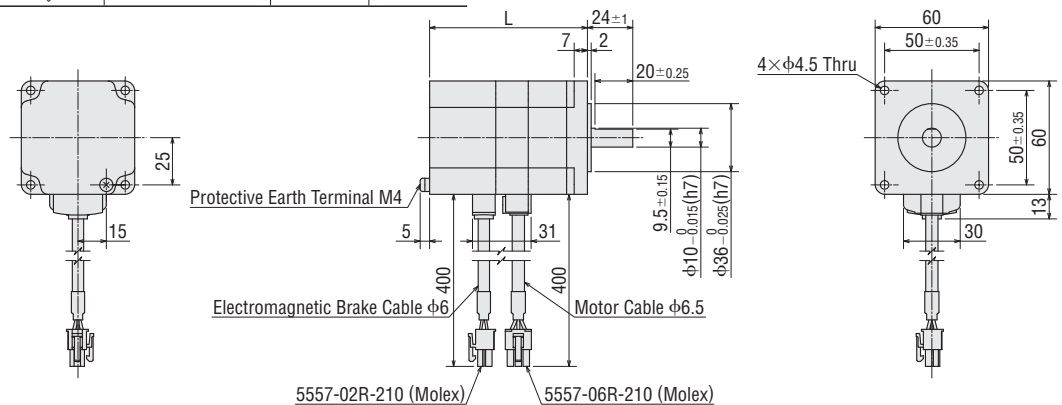

Frame Size 85 mm

Product Name		Motor Product Name	L	Mass kg
Built-in Controller	Pulse Input			
RKS596MCD-◇	RKS596MC-◇	PKE596MC	118	2.7
RKS599MCD-◇	RKS599MC-◇	PKE599MC	148	3.8
RKS5913MCD-◇	RKS5913MC-◇	PKE5913MC	178	4.9

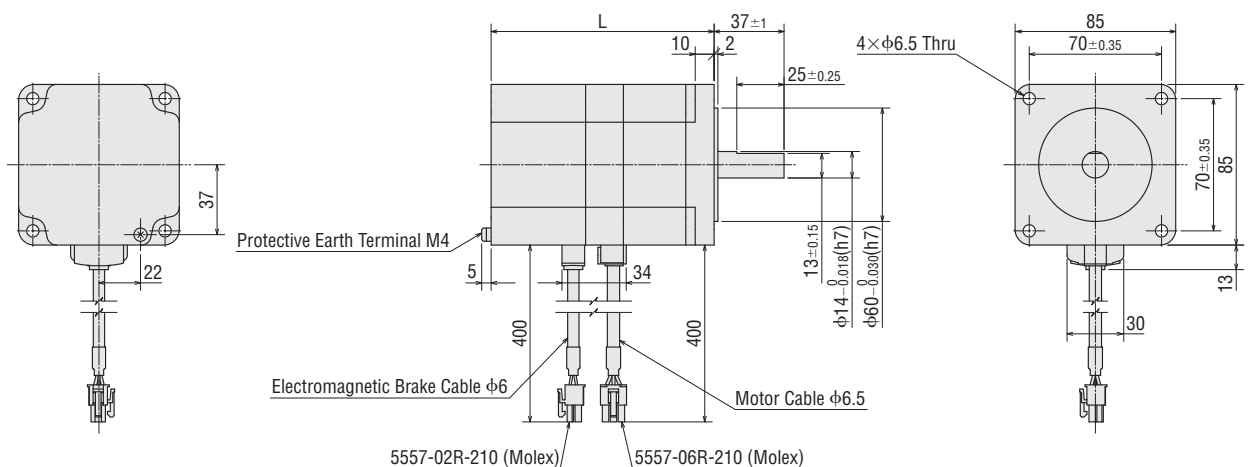

● For products that include a connection cable, a number indicating the cable length, **1** (1 m), **2** (2 m) or **3** (3 m) is specified where the box ◇ is located in the product name.
If no connection cable is included, there will be no "◇" within the product name.

◇ Standard Type with Encoder

Frame Size 42 mm

Product Name	Motor Product Name	L	Mass kg
RKS543RCD2 -◇	PKE543RC2	56	0.32
RKS544RCD2 -◇	PKE544RC2	62	0.38
RKS545RCD2 -◇	PKE545RC2	68	0.44

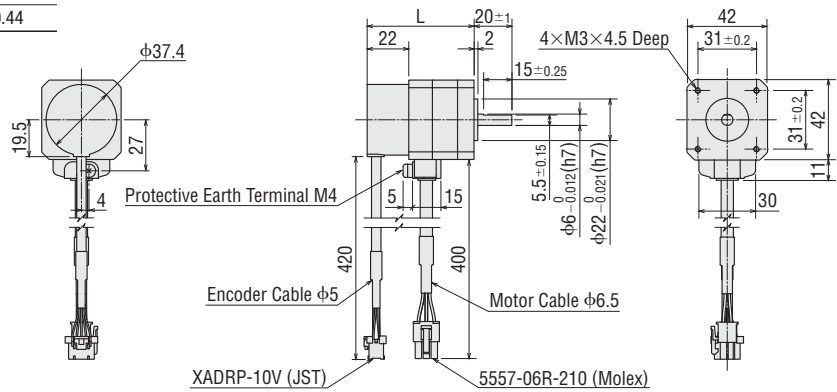

Frame Size 60 mm

Product Name	Motor Product Name	L	Mass kg
RKS564RCD2 -◇	PKE564RC2	70.5	0.76
RKS566RCD2 -◇	PKE566RC2	81.5	0.96
RKS569RCD2 -◇	PKE569RC2	111	1.5

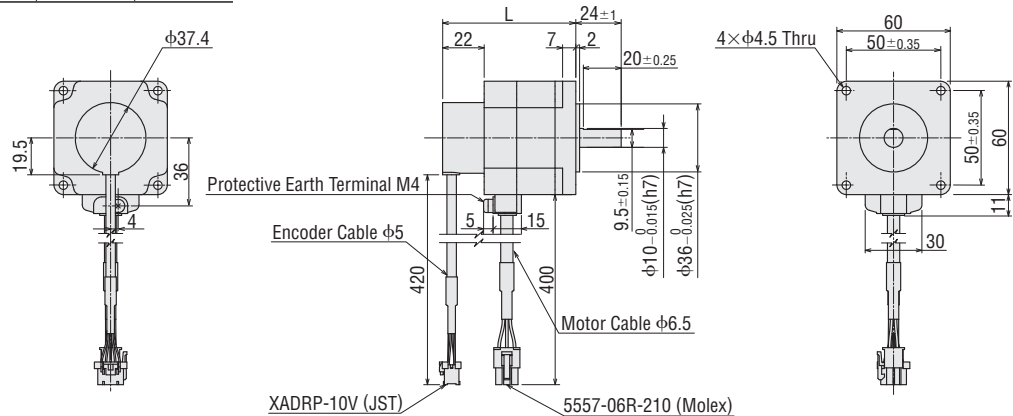

Frame Size 85 mm

Product Name	Motor Product Name	L	Mass kg
RKS596RCD2 -◇	PKE596RC2	90	2.0
RKS599RCD2 -◇	PKE599RC2	120	3.1
RKS5913RCD2 -◇	PKE5913RC2	150	4.2

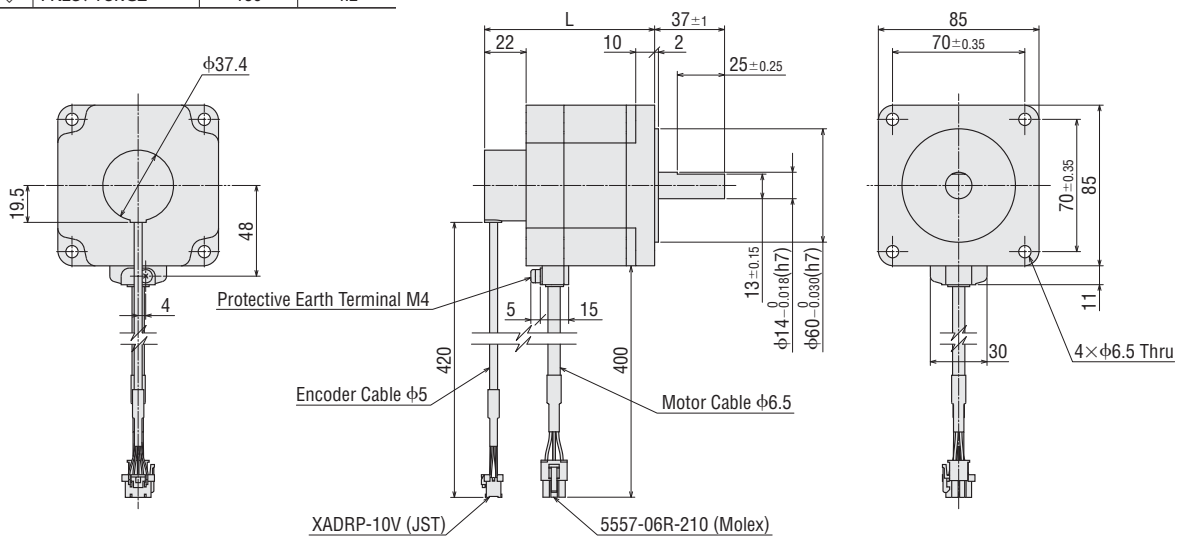

● For products that include a connection cable, a number indicating the cable length, **1** (1 m), **2** (2 m) or **3** (3 m) is specified where the box ◇ is located in the product name. If no connection cable is included, there will be no "◇" within the product name.

Overview, Product Series

AC Input Motor & Driver

0.36°/Geared
αSTEP Absolute AZ

0.36°/Geared
αSTEP AR

0.72°/Geared
RK II

DC Input Motor & Driver

0.36°/Geared
αSTEP Absolute AZ

0.36°/Geared
αSTEP AR

1.8°/0.72°/0.36°
CVK

0.72°/0.36°/Geared
CRK

1.8°/Geared
RBK

Motor Only / Driver Only

1.8°/0.9°
PKP/PK

Geared
PKP/PK

0.72°/0.36°
PKP/PK

Driver

Accessories

◇ TS Geared Type

Frame Size 42 mm

Product Name		Motor Product Name	Gear Ratio	Mass kg
Built-in Controller	Pulse Input			
RKS543ACD-TS □-◇	RKS543AC-TS □-◇	PKE543AC-TS□	3.6, 7.2,	0.41
RKS543BCD-TS □-◇	RKS543BC-TS □-◇	PKE543BC-TS□	10, 20, 30	

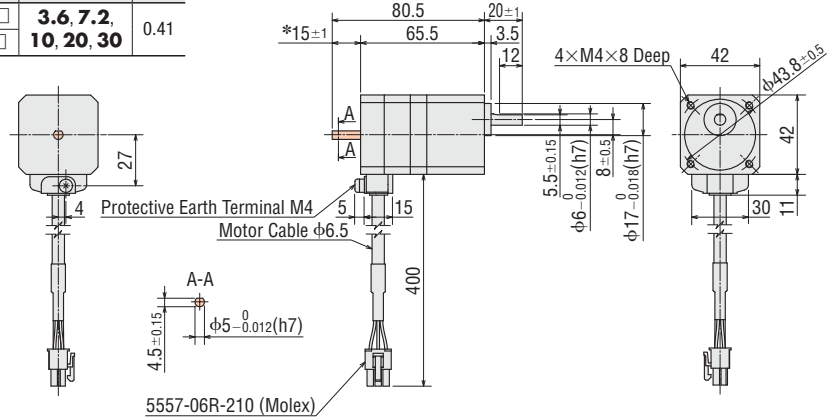

*The length of the shaft flat on the double shaft model is 15±0.25.

Frame Size 60 mm

Product Name		Motor Product Name	Gear Ratio	Mass kg
Built-in Controller	Pulse Input			
RKS564ACD-TS □-◇	RKS564AC-TS □-◇	PKE564AC-TS□	3.6, 7.2,	1.1
RKS564BCD-TS □-◇	RKS564BC-TS □-◇	PKE564BC-TS□	10, 20, 30	

● Installation Screw: M4×60 P0.7 (4 screws are included with the product)

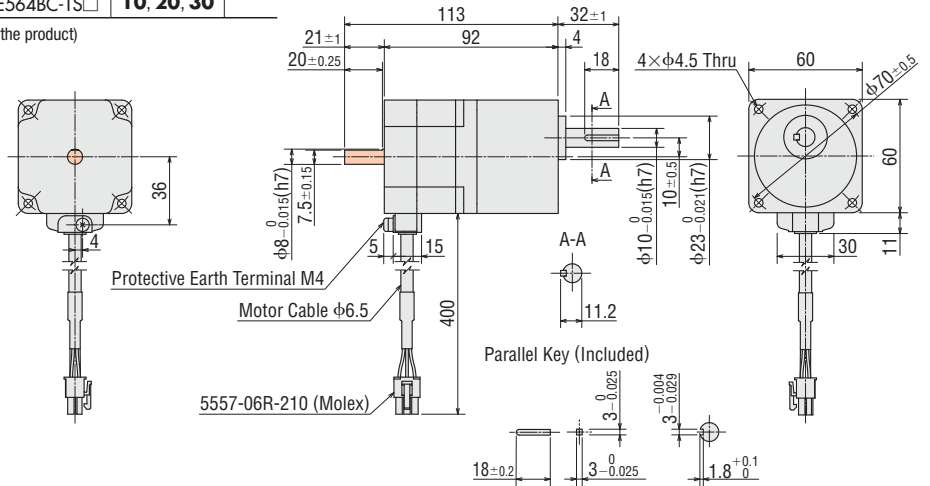

Frame Size 90 mm

Product Name		Motor Product Name	Gear Ratio	Mass kg
Built-in Controller	Pulse Input			
RKS596ACD-TS □-◇	RKS596AC-TS □-◇	PKE596AC-TS□	3.6, 7.2, 10,	3.1
RKS596BCD-TS □-◇	RKS596BC-TS □-◇	PKE596BC-TS□	20, 30	

● Installation Screw: M8×90 P1.25 (4 screws are included with the product)

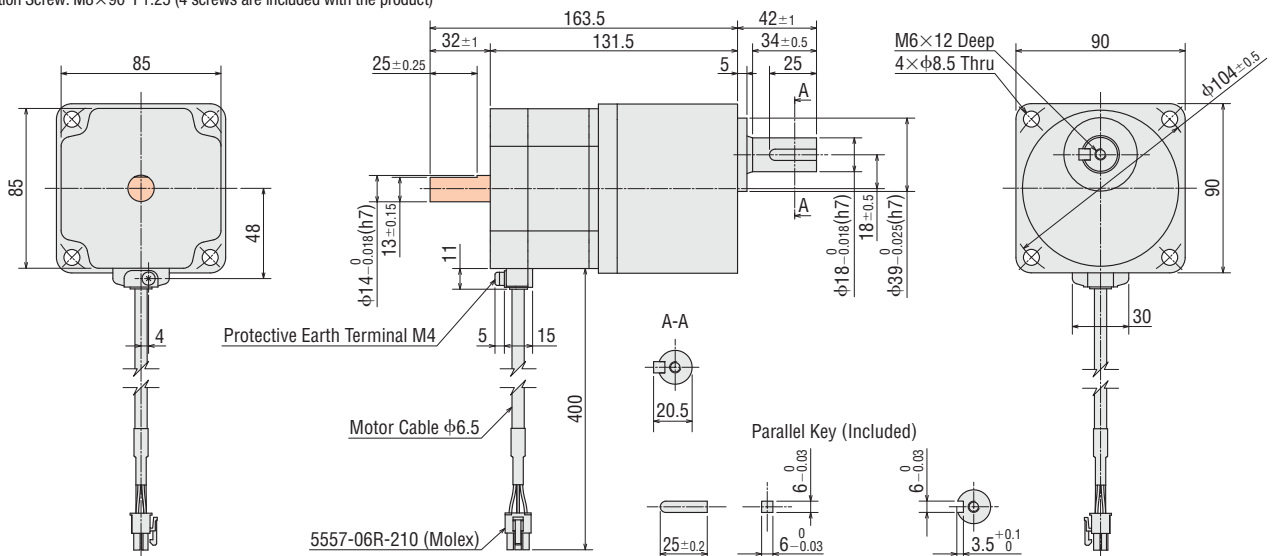

- A number indicating the gear ratio is specified where the box □ is located in the product name.
- For products that include a connection cable, a number indicating the cable length, 1 (1 m), 2 (2 m) or 3 (3 m) is specified where the box ◇ is located in the product name. If no connection cable is included, there will be no "◇" within the product name.
- These dimensions are for double shaft motors. For single shaft motors, ignore the shaded areas.

◇ TS Geared Type with Electromagnetic Brake

Frame Size 42 mm

Product Name		Motor Product Name	Gear Ratio	Mass kg
Built-in Controller	Pulse Input			
RKS543MCD-TS □-◇	RKS543MC-TS □-◇	PKE543MC-TS□	3.6, 7.2, 10, 20, 30	0.55

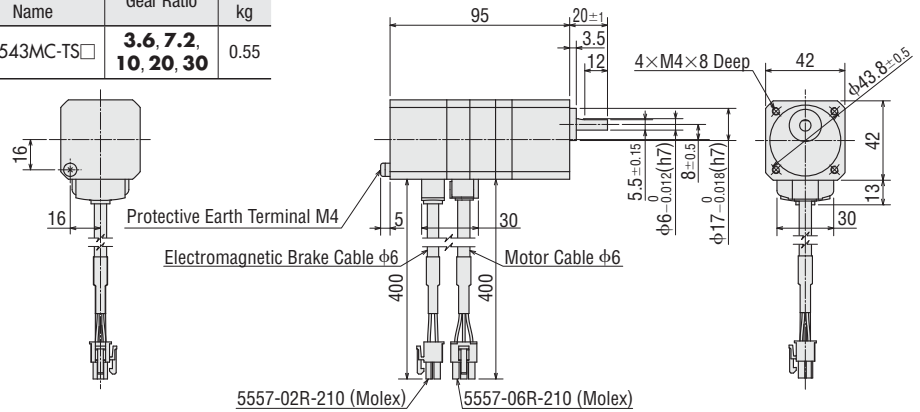

Frame Size 60 mm

Product Name		Motor Product Name	Gear Ratio	Mass kg
Built-in Controller	Pulse Input			
RKS564MCD-TS □-◇	RKS564MC-TS □-◇	PKE564MC-TS□	3.6, 7.2, 10, 20, 30	1.4

● Installation Screw: M4×60 P0.7 (4 screws are included with the product)

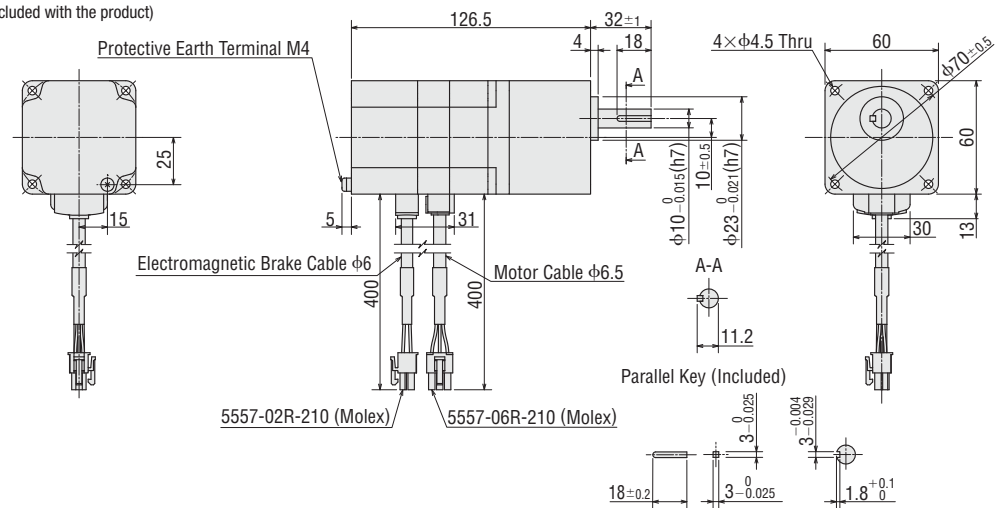

Frame Size 90 mm

Product Name		Motor Product Name	Gear Ratio	Mass kg
Built-in Controller	Pulse Input			
RKS596MCD-TS □-◇	RKS596MC-TS □-◇	PKE596MC-TS□	3.6, 7.2, 10, 20, 30	3.9

● Installation Screw: M8×90 P1.25 (4 screws are included with the product)

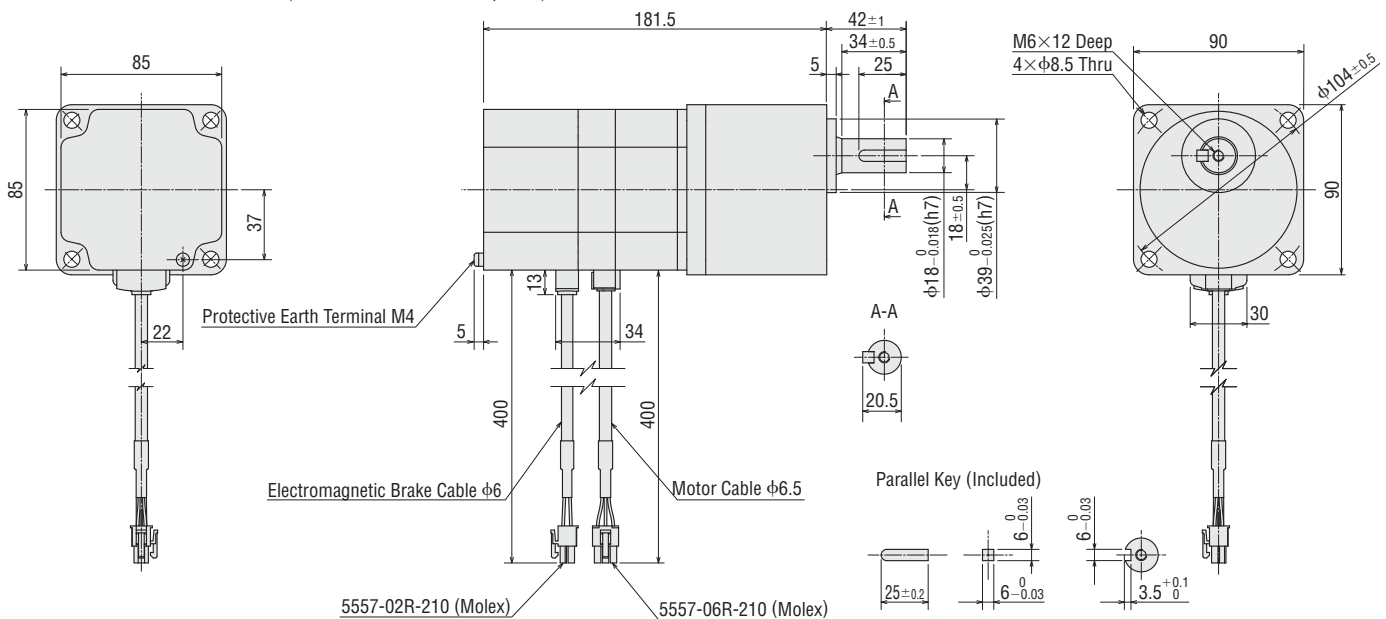

● A number indicating the gear ratio is specified where the box □ is located in the product name.

● For products that include a connection cable, a number indicating the cable length, 1 (1 m), 2 (2 m) or 3 (3 m) is specified where the box ◇ is located in the product name. If no connection cable is included, there will be no "◇" within the product name.

Overview, Product Series

AC Input Motor & Driver

0.36°/Geared
αSTEP Absolute AZ

0.36°/Geared
αSTEP AR

0.72°/Geared
RKII

DC Input Motor & Driver

0.36°/Geared
αSTEP Absolute AZ

0.36°/Geared
αSTEP AR

1.8°/0.72°/0.36°
CVK

0.72°/0.36°/Geared
CRK

1.8°/Geared
RBK

Motor Only /Driver Only

1.8°/0.9°
PKP/PK

Geared
PKP/PK

0.72°/0.36°
PKP/PK

Driver

Accessories

◇ PS Geared Type

Frame Size 42 mm

Product Name		Motor Product Name	Gear Ratio	L1	L2	Mass kg
Built-in Controller	Pulse Input					
RK545ACD-PS□-◇	RK545AC-PS□-◇	PKE545AC-PS□	5, 7.2, 10	73.5	-	0.58
RK545BCD-PS□-◇	RK545BC-PS□-◇	PKE545BC-PS□				
RK543ACD-PS□-◇	RK543AC-PS□-◇	PKE543AC-PS□	25, 36, 50	86	-	0.61
RK543BCD-PS□-◇	RK543BC-PS□-◇	PKE543BC-PS□				

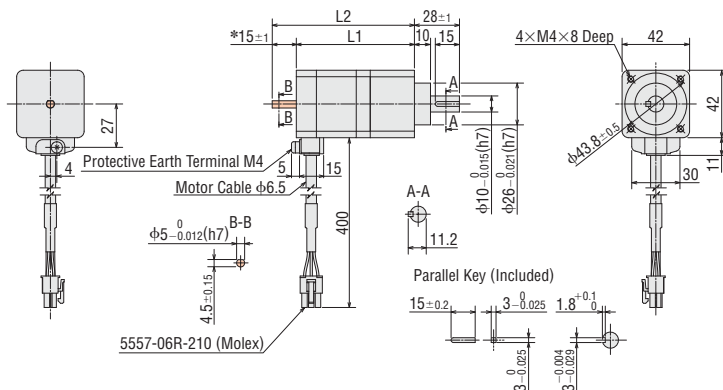

Frame Size 60 mm

Product Name		Motor Product Name	Gear Ratio	L1	L2	Mass kg
Built-in Controller	Pulse Input					
RK566ACD-PS□-◇	RK566AC-PS□-◇	PKE566AC-PS□	5, 7.2, 10	92	-	1.3
RK566BCD-PS□-◇	RK566BC-PS□-◇	PKE566BC-PS□				
RK564ACD-PS□-◇	RK564AC-PS□-◇	PKE564AC-PS□	25, 36, 50	101.5	-	1.4
RK564BCD-PS□-◇	RK564BC-PS□-◇	PKE564BC-PS□				

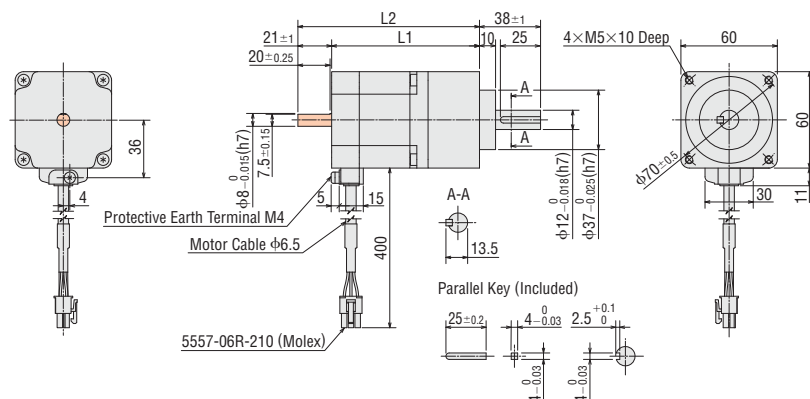

Frame Size 90 mm

Product Name		Motor Product Name	Gear Ratio	L1	L2	Mass kg
Built-in Controller	Pulse Input					
RK599ACD-PS□-◇	RK599AC-PS□-◇	PKE599AC-PS□	5, 7.2, 10	145	-	4.4
RK599BCD-PS□-◇	RK599BC-PS□-◇	PKE599BC-PS□				
RK596ACD-PS□-◇	RK596AC-PS□-◇	PKE596AC-PS□	25, 36, 50	142.5	-	4.1
RK596BCD-PS□-◇	RK596BC-PS□-◇	PKE596BC-PS□				

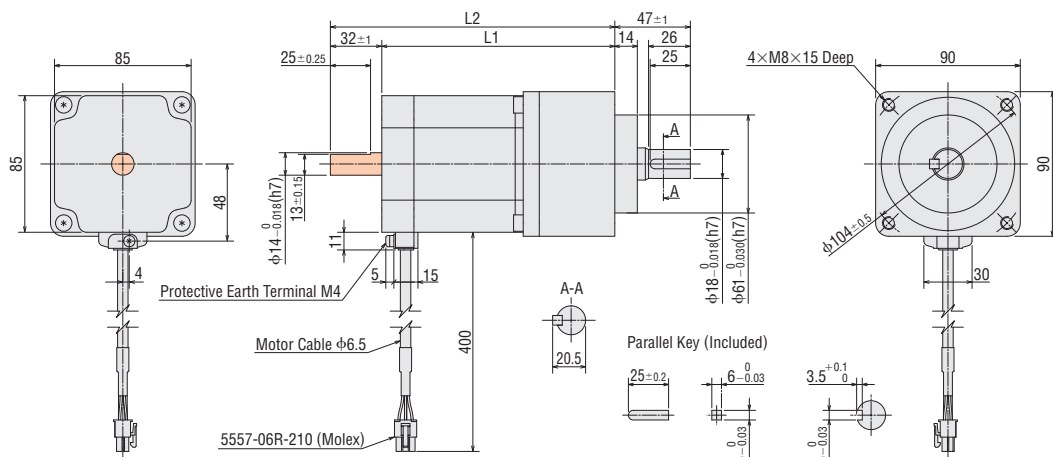

- A number indicating the gear ratio is specified where the box □ is located in the product name.
- For products that include a connection cable, a number indicating the cable length, 1 (1 m), 2 (2 m) or 3 (3 m) is specified where the box ◇ is located in the product name. If no connection cable is included, there will be no "◇" within the product name.
- These dimensions are for double shaft motors. For single shaft motors, ignore the shaded areas.

◇ PS Geared Type with Electromagnetic Brake

Frame Size 42 mm

Product Name		Motor Product Name	Gear Ratio	L	Mass kg
Built-in Controller	Pulse Input				
RKS545MCD-PS □-◇	RKS545MC-PS □-◇	PKE545MC-PS□	5, 7, 2, 10	103	0.72
RKS543MCD-PS □-◇	RKS543MC-PS □-◇	PKE543MC-PS□	25, 36, 50	115.5	0.75

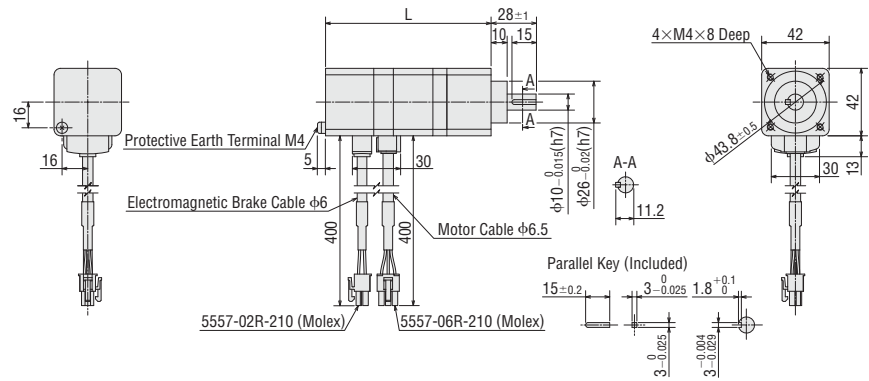

Overview, Product Series

AC Input Motor & Driver

0.36°/Geared
αSTEP Absolute AZ

0.36°/Geared
αSTEP AR

0.72°/Geared
RKII

Frame Size 60 mm

Product Name		Motor Product Name	Gear Ratio	L	Mass kg
Built-in Controller	Pulse Input				
RKS566MCD-PS □-◇	RKS566MC-PS □-◇	PKE566MC-PS□	5, 7, 2, 10	127	1.6
RKS564MCD-PS □-◇	RKS564MC-PS □-◇	PKE564MC-PS□	25, 36, 50	136	1.7

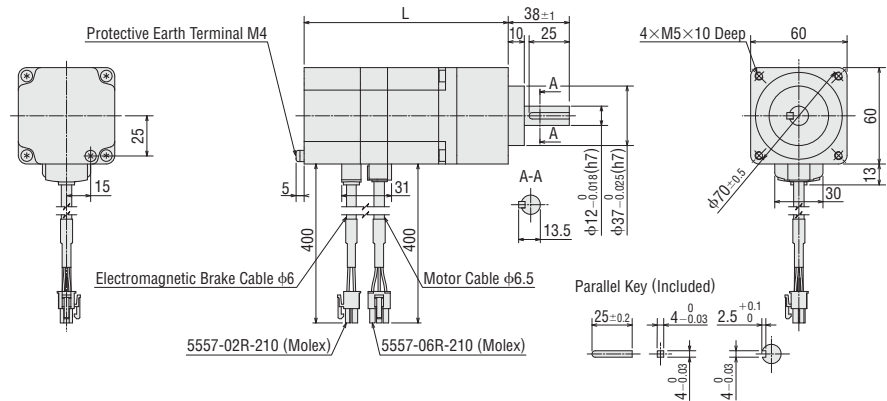

DC Input Motor & Driver

0.36°/Geared
αSTEP Absolute AZ

0.36°/Geared
αSTEP AR

1.8°/0.72°/0.36°
CVK

0.72°/0.36°/Geared
CRK

1.8°/Geared
RBK

Frame Size 90 mm

Product Name		Motor Product Name	Gear Ratio	L	Mass kg
Built-in Controller	Pulse Input				
RKS599MCD-PS □-◇	RKS599MC-PS □-◇	PKE599MC-PS□	5, 7, 2, 10	195	5.2
RKS596MCD-PS □-◇	RKS596MC-PS □-◇	PKE596MC-PS□	25, 36, 50	192	4.9

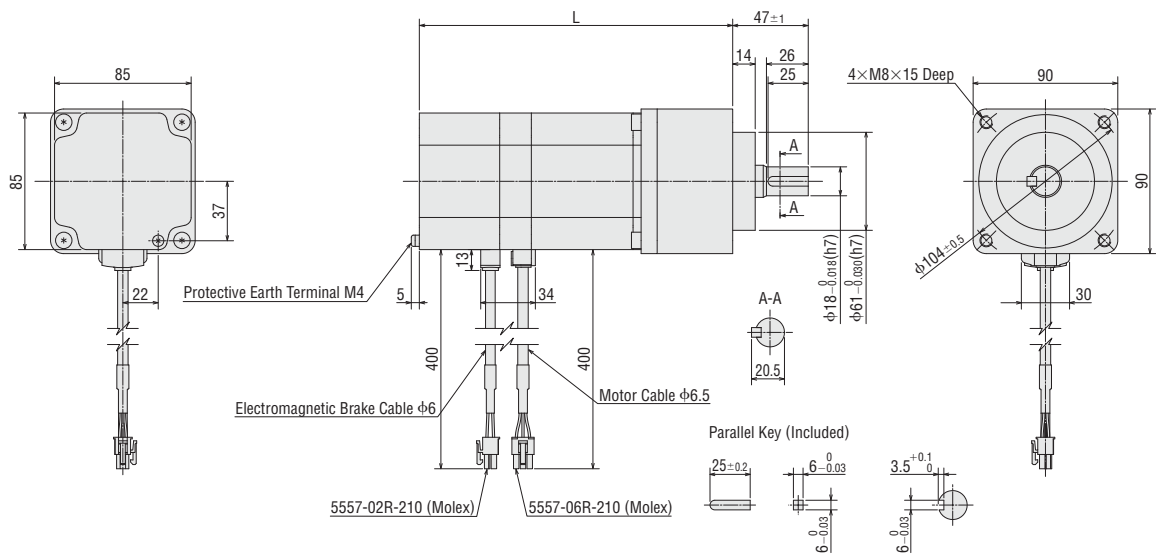

Motor Only / Driver Only

1.8°/0.9°
PKP/PK

Geared
PKP/PK

0.72°/0.36°
PKP/PK

Driver

Accessories

● A number indicating the gear ratio is specified where the box □ is located in the product name.

● For products that include a connection cable, a number indicating the cable length, **1** (1 m), **2** (2 m) or **3** (3 m) is specified where the box ◇ is located in the product name. If no connection cable is included, there will be no "◇" within the product name.

◇ Harmonic Geared Type

Frame Size 42 mm

Product Name		Motor Product Name	Gear Ratio	Mass kg
Built-in Controller	Pulse Input			
RK543ACD-HS□-◇	RK543AC-HS□-◇	PKE543AC-HS□	50, 100	0.47
RK543BCD-HS□-◇	RK543BC-HS□-◇	PKE543BC-HS□		

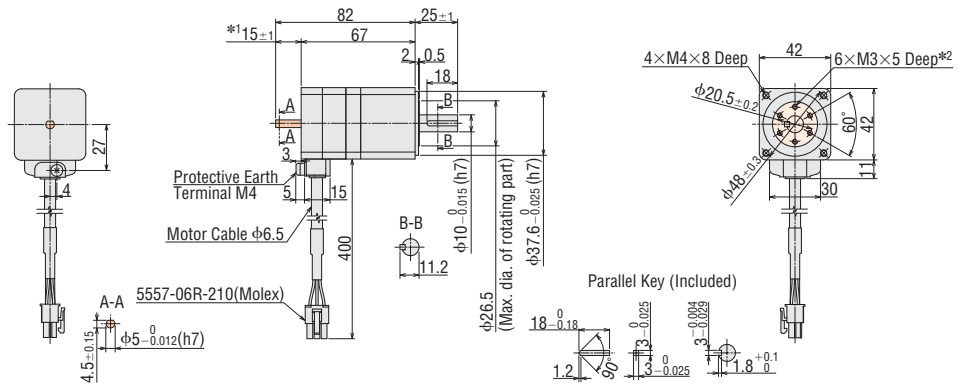

*1 The length of the shaft flat on the double shaft model is 15±0.25.
*2 The position of the output shaft relative to the screw holes on the rotating part is arbitrary.

Frame Size 60 mm

Product Name		Motor Product Name	Gear Ratio	Mass kg
Built-in Controller	Pulse Input			
RK564ACD-HS□-◇	RK564AC-HS□-◇	PKE564AC-HS□	50, 100	1.2
RK564BCD-HS□-◇	RK564BC-HS□-◇	PKE564BC-HS□		

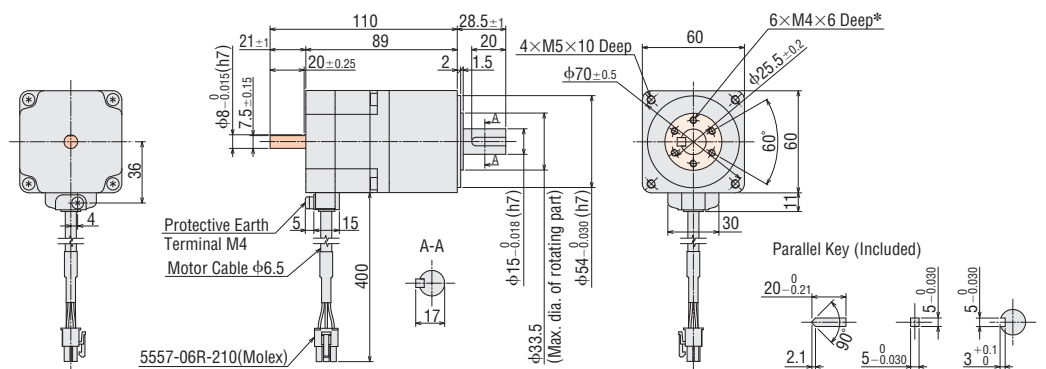

*The position of the output shaft relative to the screw holes on the rotating part is arbitrary.

Frame Size 90 mm

Product Name		Motor Product Name	Gear Ratio	Mass kg
Built-in Controller	Pulse Input			
RK596ACD-HS□-◇	RK596AC-HS□-◇	PKE596AC-HS□	50, 100	3.9
RK596BCD-HS□-◇	RK596BC-HS□-◇	PKE596BC-HS□		

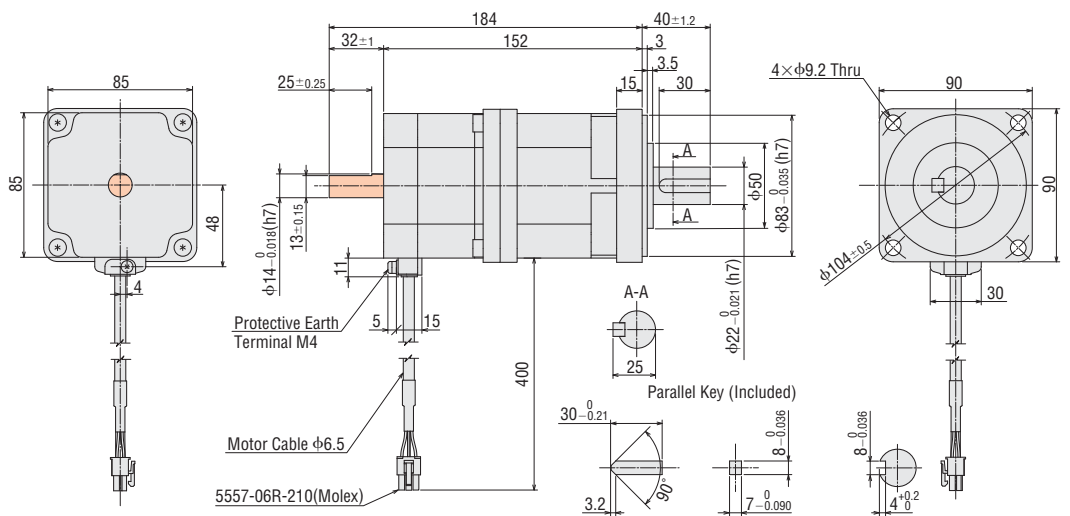

- A number indicating the gear ratio is specified where the box □ is located in the product name.
- For products that include a connection cable, a number indicating the cable length, 1 (1 m), 2 (2 m) or 3 (3 m) is specified where the box ◇ is located in the product name. If no connection cable is included, there will be no "◇" within the product name.
- These dimensions are for double shaft motors. For single shaft motors, ignore the shaded areas.
- The shaded areas are rotating parts.

◇ Harmonic Geared Type with Electromagnetic Brake

Frame Size 42 mm

Product Name		Motor Product Name	Gear Ratio	Mass kg
Built-in Controller	Pulse Input			
RKS543MCD-HS □-◇	RKS543MC-HS □-◇	PKE543MC-HS □	50, 100	0.61

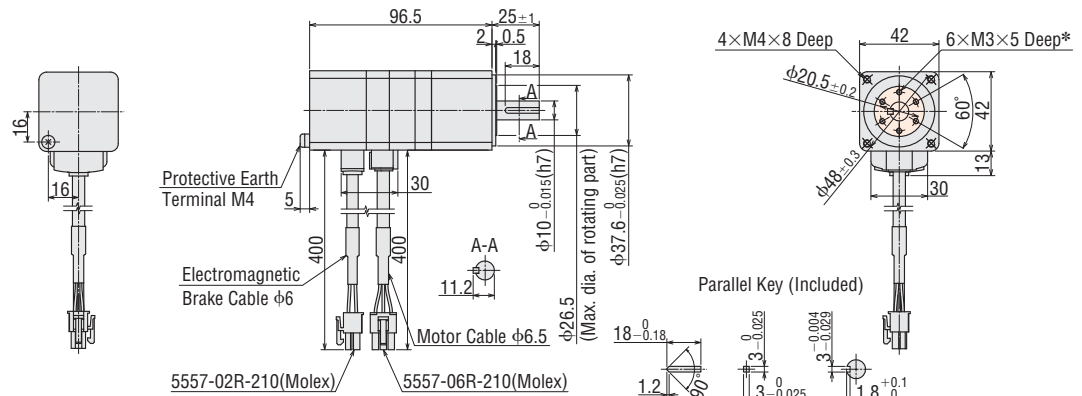

*The position of the output shaft relative to the screw holes on the rotating part is arbitrary.

Frame Size 60 mm

Product Name		Motor Product Name	Gear Ratio	Mass kg
Built-in Controller	Pulse Input			
RKS564MCD-HS □-◇	RKS564MC-HS □-◇	PKE564MC-HS □	50, 100	1.5

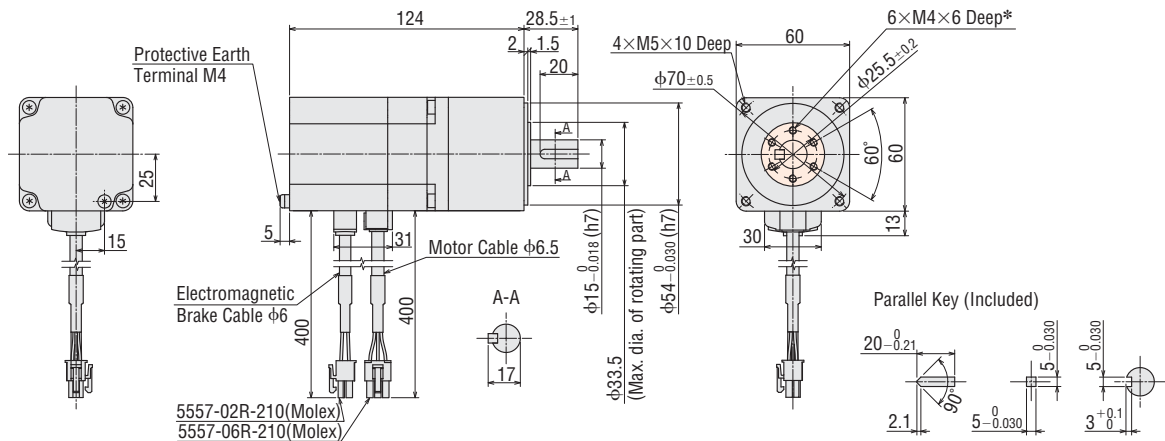

*The position of the output shaft relative to the screw holes on the rotating part is arbitrary.

Frame Size 90 mm

Product Name		Motor Product Name	Gear Ratio	Mass kg
Built-in Controller	Pulse Input			
RKS596MCD-HS □-◇	RKS596MC-HS □-◇	PKE596MC-HS □	50, 100	4.8

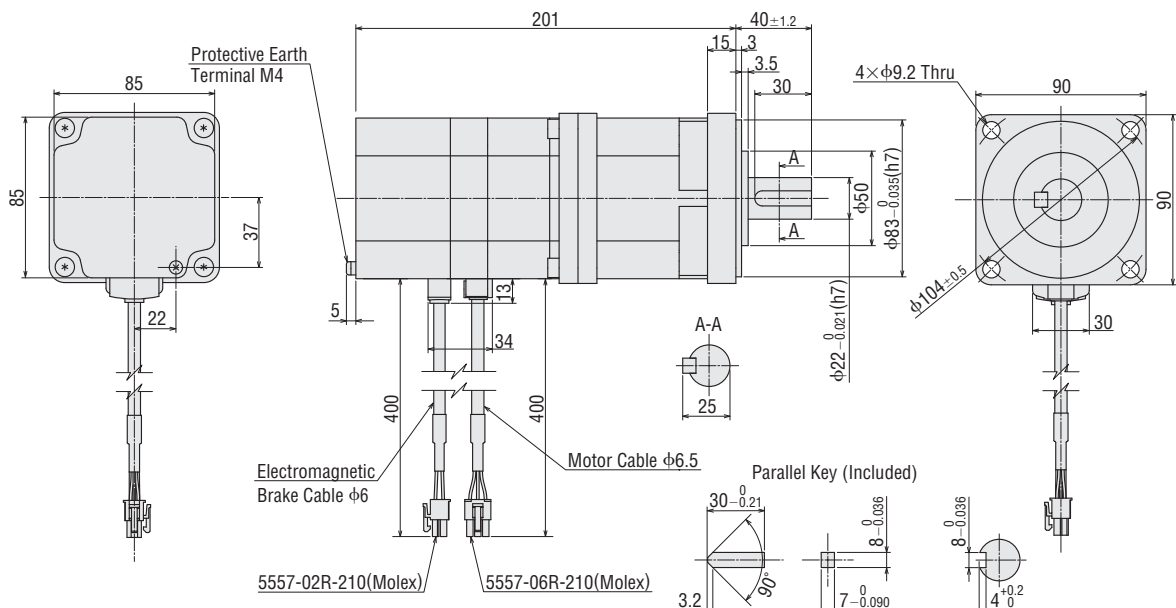

- A number indicating the gear ratio is specified where the box □ is located in the product name.
- For products that include a connection cable, a number indicating the cable length, **1** (1 m), **2** (2 m) or **3** (3 m) is specified where the box ◇ is located in the product name. If no connection cable is included, there will be no "◇" within the product name.
- The shaded areas are rotating parts.

Overview, Product Series

AC Input Motor & Driver

0.36°/Geared
αSTEP Absolute AZ

0.36°/Geared
αSTEP AR

0.72°/Geared
RKII

DC Input Motor & Driver

0.36°/Geared
αSTEP Absolute AZ

0.36°/Geared
αSTEP AR

1.8°/0.72°/0.36°
CVK

0.72°/0.36°/Geared
CRK

1.8°/Geared
RBK

Motor Only / Driver Only

1.8°/0.9°
PKP/PK

Geared
PKP/PK

0.72°/0.36°
PKP/PK

Driver

Accessories

● Cable for Motor (Included), Cable for Electromagnetic Brake (Included), Cable for Encoder (Included)

● Only for products in which a connection cable is included

◇ Cable for Motor

Cable Type	Length L (m)
Cable for Motor 1 m	1
Cable for Motor 2 m	2
Cable for Motor 3 m	3

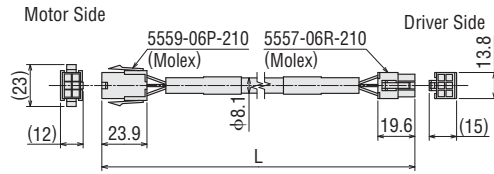

◇ Cable for Electromagnetic Brake (Only for electromagnetic brake product)

Cable Type	Length L (m)
Cable for Electromagnetic Brake 1 m	1
Cable for Electromagnetic Brake 2 m	2
Cable for Electromagnetic Brake 3 m	3

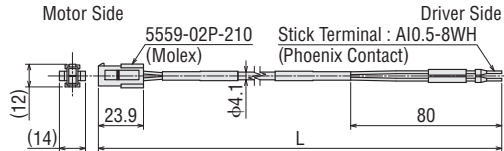

◇ Cable for Encoder (Only for encoder product)

Cable Type	Length L (m)
Cable for Encoder 1 m	1
Cable for Encoder 2 m	2
Cable for Encoder 3 m	3

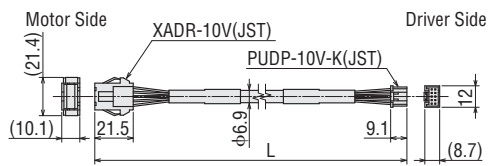

● Drivers

◇ Built-in Controller Type

Mass: 0.8 kg

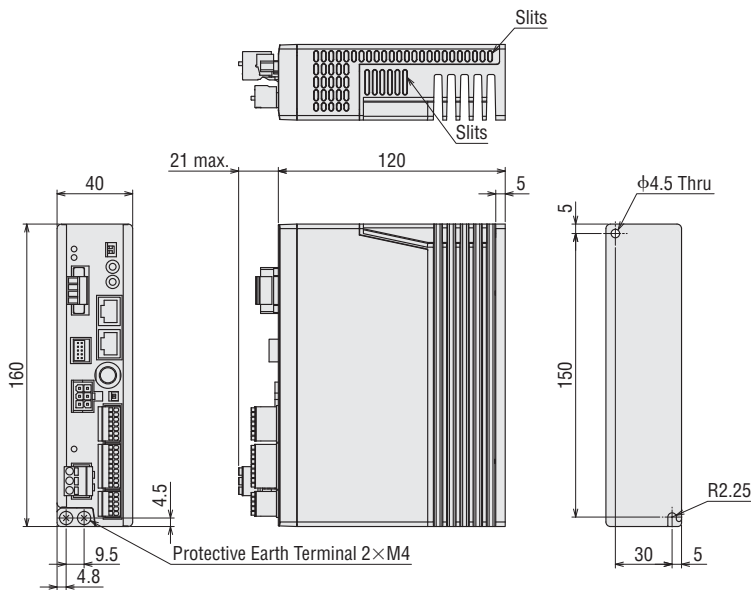

● Accessories

- Connector for Power Input Terminal (CN1)
Connector: MC1.5/4-STF-3,5 (Phoenix Contact GmbH & Co.,KG.)
- Connector for Sensor Signal (CN5)
Connector: FK-MC0,5/5-ST-2,5 (Phoenix Contact GmbH & Co.,KG.)
- Connector for Input Signal (CN8)
Connector: FK-MC0,5/9-ST-2,5 (Phoenix Contact GmbH & Co.,KG.)
- Connector for Output Signal (CN9)
Connector: FK-MC0,5/7-ST-2,5 (Phoenix Contact GmbH & Co.,KG.)
- Connector for Main Power Supply (CN3)
Connector: FKCT2,5/3-ST-5,08 (Phoenix Contact GmbH & Co.,KG.)

◇ Pulse Input Type

● Standard Type

Mass: 0.8 kg

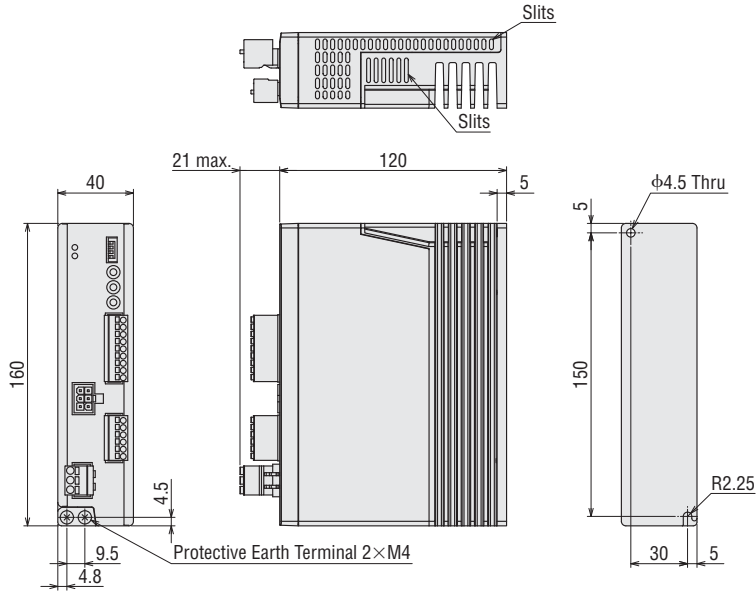

● Included

- I/O Signal Connector (CN5)
Connector: FK-MCP1,5/9-ST-3,81 (Phoenix Contact GmbH & Co.,KG.)
- Pulse Input Connector (CN4)
Connector: FK-MCP1,5/6-ST-3,81 (Phoenix Contact GmbH & Co.,KG.)
- Power Source Input Connector (CN3)
Connector: FKCT2,5/3-ST-5,08 (Phoenix Contact GmbH & Co.,KG.)

● Standard Type with Electromagnetic Brake

Mass: 0.8 kg

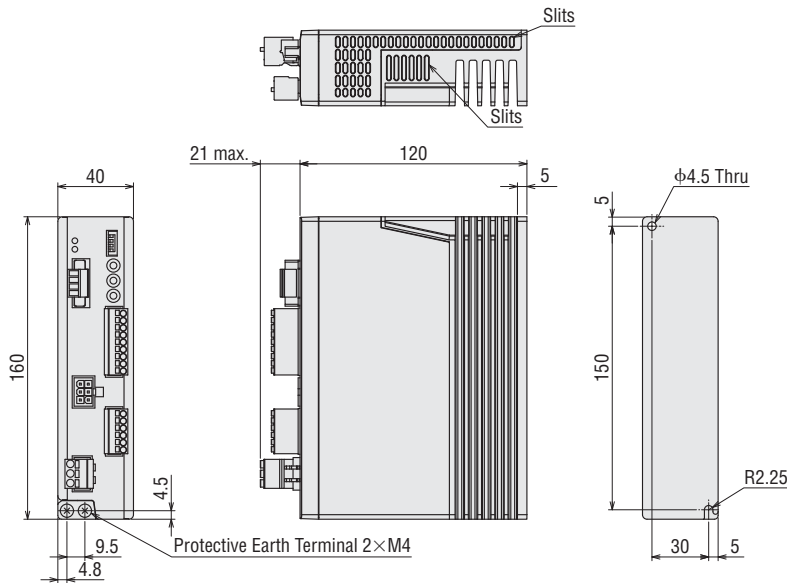

● Included

- I/O Signal Connector (CN5)
Connector: FK-MCP1,5/9-ST-3,81 (Phoenix Contact GmbH & Co.,KG.)
- Pulse Input Connector (CN4)
Connector: FK-MCP1,5/6-ST-3,81 (Phoenix Contact GmbH & Co.,KG.)
- Electromagnetic Brake Connection Terminal Connector (CN1)
Connector: MC1,5/4-STF-3,5 (Phoenix Contact GmbH & Co.,KG.)
- Power Source Input Connector (CN3)
Connector: FKCT2,5/3-ST-5,08 (Phoenix Contact GmbH & Co.,KG.)

Overview,
Product
Series

AC Input
Motor &
Driver

0.36°/Geared
αSTEP
Absolute
AZ

0.36°/Geared
αSTEP
AR

0.72°/Geared
RKII

DC Input
Motor &
Driver

0.36°/Geared
αSTEP
Absolute
AZ

0.36°/Geared
αSTEP
AR

1.8°/0.72°
/0.36°
CVK

0.72°/0.36°
/Geared
CRK

1.8°/Geared
RBK

Motor Only
/Driver Only

1.8°/0.9°
PKP/PK

Geared
PKP/PK

0.72°/0.36°
PKP/PK

Driver

Accessories

Connection and Operation (Built-in controller type)

Names and Functions of Driver Parts

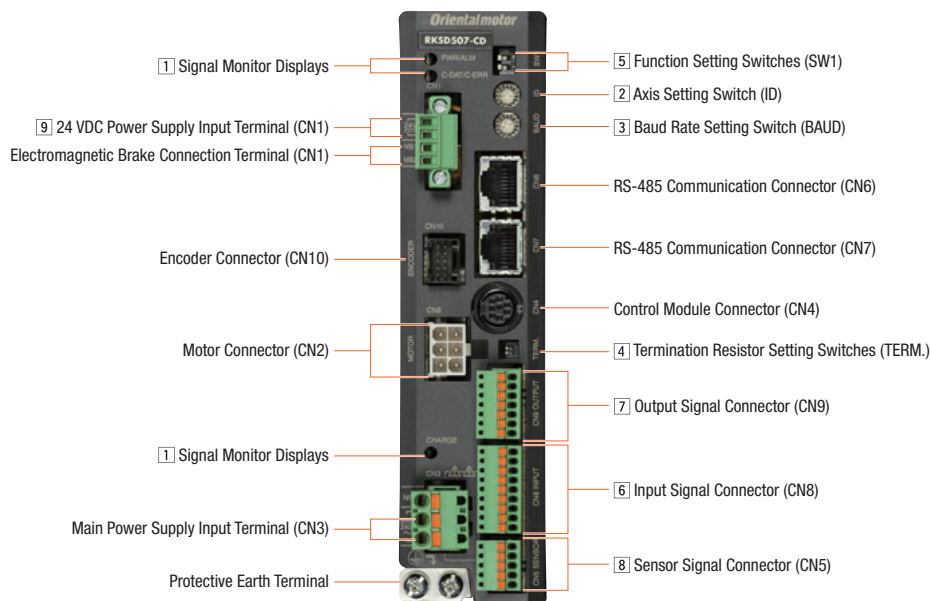

1 Signal Monitor Displays

◇ LED Indicators

Indication	Color	Function	When Activated
PWR	Green	Power Supply Indication	Lights when 24 VDC power is on.
ALM	Red	Alarm Indication	Blinks when protective functions are activated.
C-DAT	Green	Communication Indication	Lights when communication data is received or sent.
C-ERR	Red	Communication Error Indication	Lights when there is an error with communication data.
CHARGE	Red	Power On Indication	Lights when main power is supplied.

2 Axis Setting Switch (ID)

Indication	Switch Name	Function
ID	Axis Setting Switch	Set the axis number for RS-485 communication (Factory Setting: 0).

3 Baud Rate Setting Switch (BAUD)

Indication	Switch Name	Function
BAUD	Baud Rate Setting Switch	Set the baud rate for RS-485 communications (Factory Setting: 7).

◇ Setting the Baud Rate for RS-485 Communications

No.	Baud Rate (bps)
0	9600
1	19200
2	38400
3	57600
4	115200
5~6	Not used
7	625000 (Connect to Network Converter)
8~F	Not used

4 Termination Resistor Setting Switches (TERM.)

Indication	No.	Function
TERM.	1	Set the termination resistor (120 Ω) for RS-485 communication (Factory setting: OFF).
	2	OFF : No termination resistor ON : Set the termination resistor

*Please use the same settings for both No. 1 and No. 2.

5 Function Setting Switches (SW1)

Indication	No.	Function
SW1	1	Set the axis number in combination with the axis setting switch (ID) (Factory setting: OFF).
	2	Set the protocol for RS-485 communication (Factory setting: OFF).

◇ RS-485 Communication Protocol Setting

No.	Destination	Connect to Network Converter	Modbus RTU Mode
	2		OFF

6 Input Signal Connector (CN8)

Indication	Pin No.	Signal Name	Description	
CN8	1	IN0	HOME Perform the return-to-home operation.	
	2	IN1	START Perform the positioning operation.	
	3	IN2	M0	
	4	IN3	M1	The operating data number is selected using 3 bits.
	5	IN4	M2	
	6	IN5	FREE	Stop motor excitation and release the electromagnetic brake.
	7	IN6	STOP	Stop the motor.
	8	IN7	ALM-RST	Reset the current alarm.
	9	IN-COM1	Common for Input Signals	

*Assigned functions are set by means of the parameter settings. The above is the initial value. For details, refer to the User Manual.

The following input signals can be assigned to input terminals IN0~7.

Input Signal									
0: Not used	5: SSTART	10: MS2	17: AWO	32: R0	37: R5	42: R10	47: R15	52: M4	
1: FWD	6: +JOG	11: MS3	18: STOP	33: R1	38: R6	43: R11	48: M0	53: M5	
2: RVS	7: -JOG	12: MS4	24: ALM-RST	34: R2	39: R7	44: R12	49: M1		
3: HOME	8: MS0	13: MS5	25: P-PRESET	35: R3	40: R8	45: R13	50: M2		
4: START	9: MS1	16: FREE	27: HMI	36: R4	41: R9	46: R14	51: M3		

7 Output Signal Connector (CN9)

Indication	Pin No.	Signal Name	Description
CN9	1	OUT0	HOME-P Output when the motor is home.
	2	OUT1	MOVE Output while the motor is under operation.
	3	OUT2	AREA1 Output when the motor is in area 1.
	4	OUT3	READY Output when driver operation preparations have finished.
	5	OUT4	WNG The driver's warning status is output.
	6	OUT5	ALM The driver's alarm status is output (normally closed).
	7	OUT-COM	Common for Output Signals

*Assigned functions are set by means of the parameter settings. The above is the initial value. For details, refer to the User Manual.

The following output signals can be assigned to output terminals OUT0~5.

Output Signal									
0: Not used	7: -JOG_R	16: FREE_R	36: R4	43: R11	50: M2_R	63: SLIT_R	73: AREA1	85: ZSG	
1: FWD_R	8: MS0_R	17: AWO_R	37: R5	44: R12	51: M3_R	65: ALM	74: AREA2	86: MBC	
2: RVS_R	9: MS1_R	18: STOP_R	38: R6	45: R13	52: M4_R	66: WNG	75: AREA3		
3: HOME_R	10: MS2_R	32: R0	39: R7	46: R14	53: M5_R	67: READY	80: S-BSY		
4: START_R	11: MS3_R	33: R1	40: R8	47: R15	60: +LS_R	68: MOVE	82: MPS		
5: SSTART_R	12: MS4_R	34: R2	41: R9	48: M0_R	61: -LS_R	70: HOME-P	83: STEP/OUT		
6: +JOG_R	13: MS5_R	35: R3	42: R10	49: M1_R	62: HOMES_R	72: TIM	84: OH		

8 Sensor Signal Connector (CN5)

Indication	Pin No.	Signal Name	Description
CN5	1	+LS	+Side Limit Sensor Input
	2	-LS	-Side Limit Sensor Input
	3	HOMES	Mechanical Home Sensor Input
	4	SLIT	Slit Sensor Input
	5	IN-COM2	Common for Sensor

9 24 VDC Power Supply Input/Electromagnetic Brake Connection Terminal (CN1)

Indication	I/O	Terminal Name	Content
24V+	Input	24 VDC Power Supply Input Terminal+	The power supply for the driver's control circuit terminal. Always connect while operating.
24V-		24 VDC Power Supply Input Terminal-	
MB1	Output	Electromagnetic Brake Connection Terminal- (Black)	Connect with the electromagnetic brake line of an electromagnetic brake motor.
MB2		Electromagnetic Brake Connection Terminal+ (White)	

Overview, Product Series

AC Input Motor & Driver

0.36°/Geared
αSTEP
Absolute
AZ

0.36°/Geared
αSTEP
AR

0.72°/Geared
RKII

DC Input Motor & Driver

0.36°/Geared
αSTEP
Absolute
AZ

0.36°/Geared
αSTEP
AR

1.8°/0.72°
/0.36°
CVK

0.72°/0.36°
/Geared
CRK

1.8°/Geared
RBK

Motor Only /Driver Only

1.8°/0.9°
PKP/PK

Geared
PKP/PK

0.72°/0.36°
PKP/PK

Driver

Accessories

● Connection Diagram

◇ Connection to Peripheral Equipment

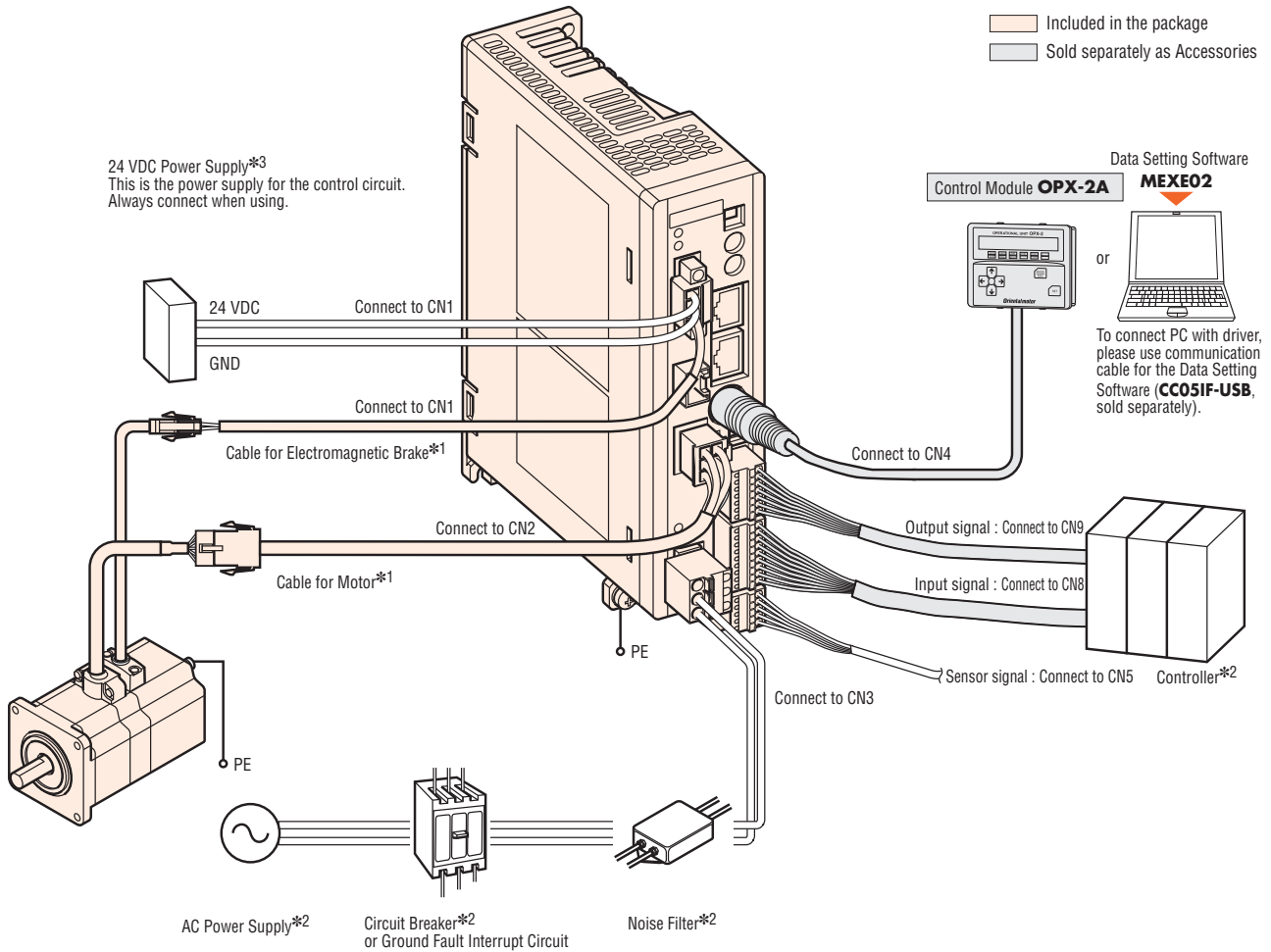

*1 Products are available with or without a 1 m, 2 m or 3 m cable that connects the motor and driver.
If cables longer than 3 m or flexible cables are required, select the appropriate cables from the accessories (sold separately).
When wiring the motor and the driver, keep a maximum distance of 20 m.

*2 Not Supplied.

*3 Not Supplied. If the wiring distance between the motor and driver is extended to 15 m or longer by using an accessory cable (sold separately), the 24 VDC±4% specification applies.

◇ Connecting to a Host Controller

● Connecting to a Current Source Output Circuit

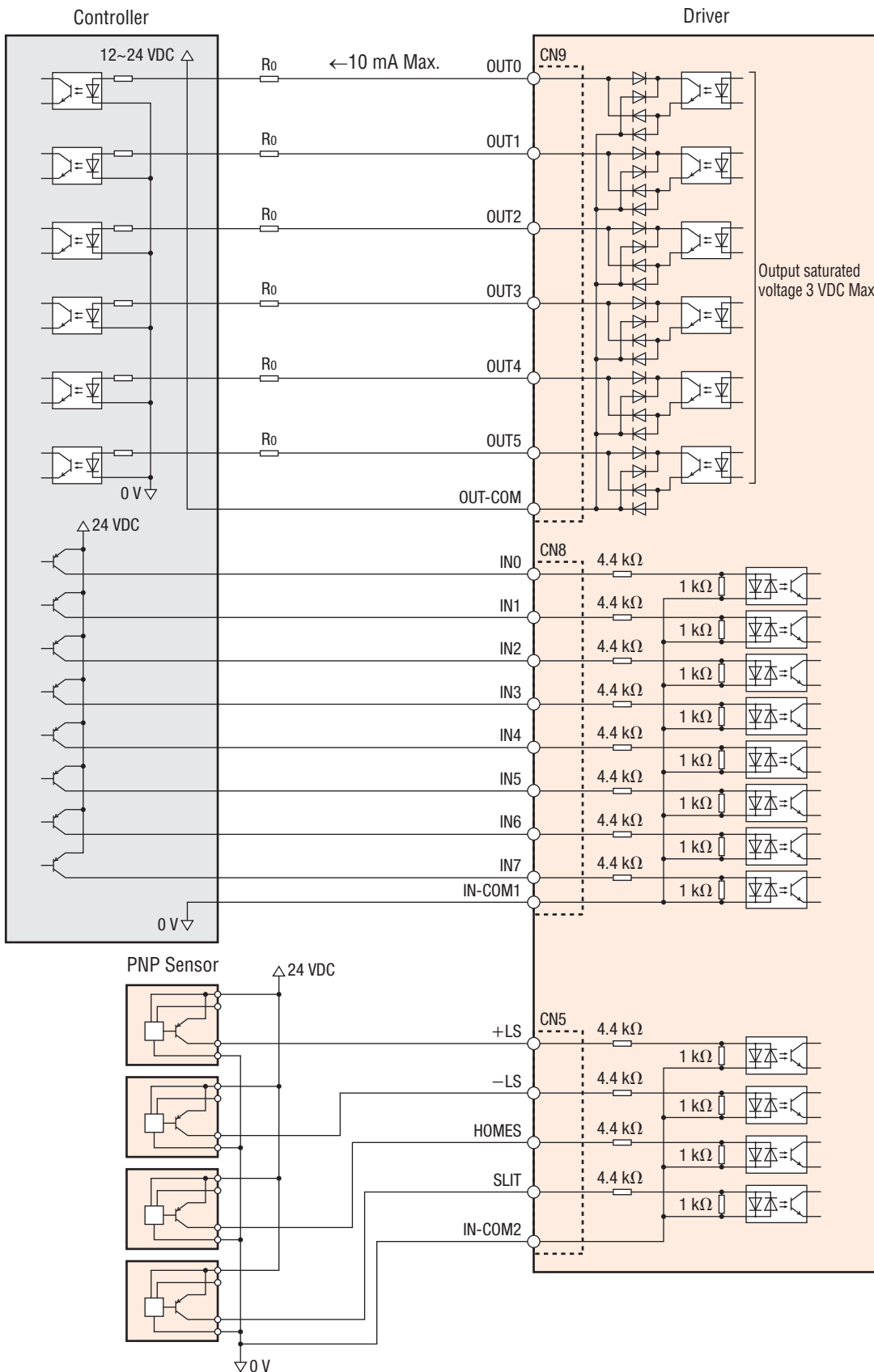

Note

- Use 24 VDC for the input signal.
- Use output signals at 12~24 VDC/10 mA or less. If the current exceeds 10 mA, connect an external resistor R_0 to adjust current value to less than 10 mA.
- Output saturated voltage should be less than 3 VDC.
- Signal lines should be kept at least 100 mm away from power lines (power supply lines and motor lines).
Do not run the signal lines in the same duct or bundle them together.
- If noise generated by the motor cables or power supply cables causes a problem, try shielding the cables or using ferrite cores.

Overview,
Product
Series

AC Input
Motor &
Driver

0.36°/Geared
**αSTEP
Absolute
AZ**

0.36°/Geared
**αSTEP
AR**

0.72°/Geared
RKII

DC Input
Motor &
Driver

0.36°/Geared
**αSTEP
Absolute
AZ**

0.36°/Geared
**αSTEP
AR**

1.8°/0.72°
/0.36°
CVK

0.72°/0.36°
/Geared
CRK

1.8°/Geared
RBK

Motor Only
/Driver Only

1.8°/0.9°
PKP/PK

Geared
PKP/PK

0.72°/0.36°
PKP/PK

Driver

Accessories

◇ Connecting to a Host Controller

● Connecting to a Current Sink Output Circuit

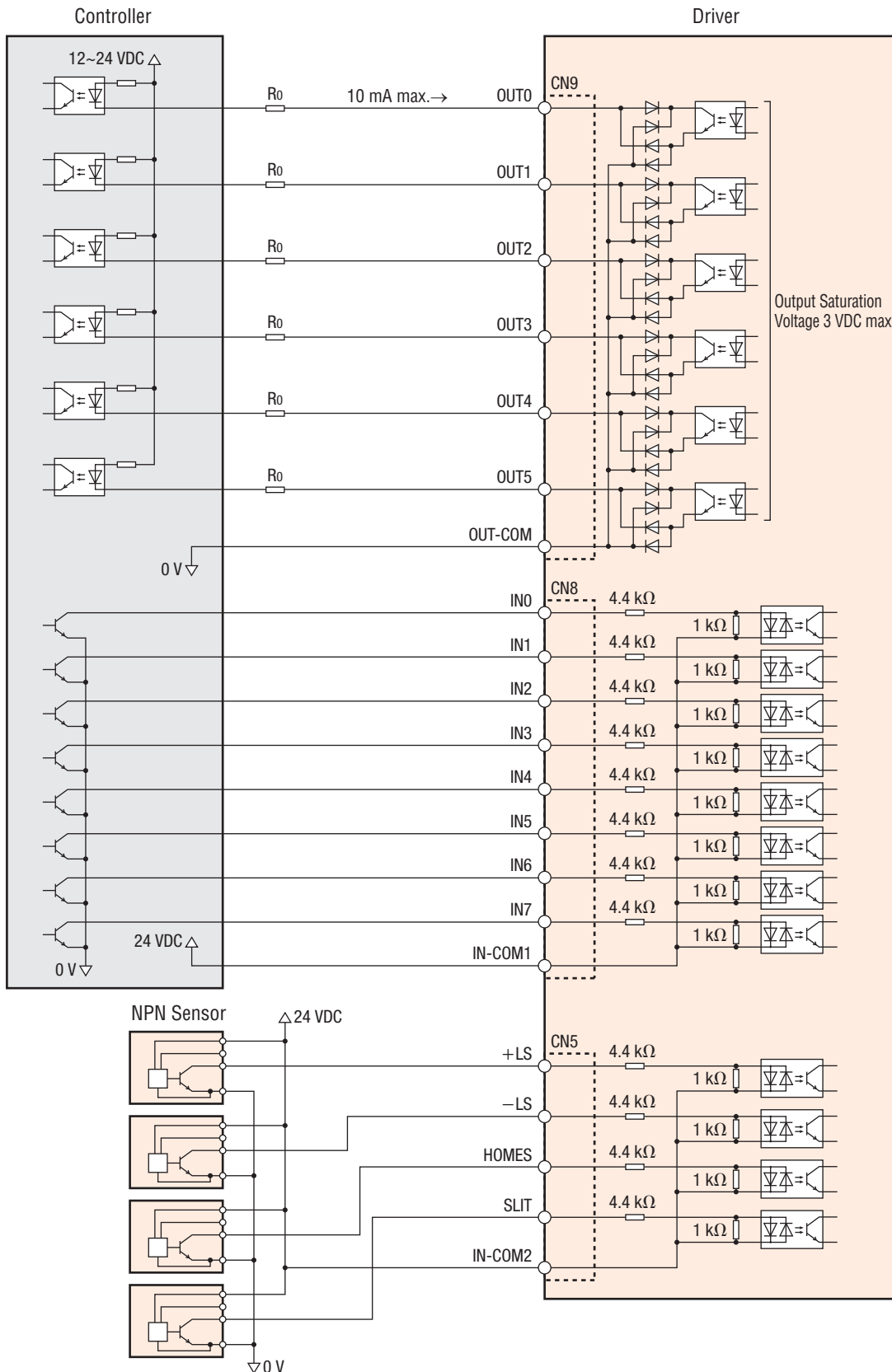

Note

- Use input signals at 24 VDC.
- Use output signals at 12~24 VDC/10 mA or less. If the current exceeds 10 mA, connect an external resistor R_o to adjust current value to less than 10 mA.
- Output saturated voltage should be less than 3 VDC.
- Provide a minimum distance of 100 mm between the signal lines and power lines (Power supply lines, motor lines).
Do not run the signal lines in the same duct as power lines or bundle them with power lines.
- If noise generated by the motor cable or power supply cable causes a problem with the specific wiring or layout, shield the cable or ferrite core.

Connection and Operation (Pulse input type)

Names and Functions of Driver Parts

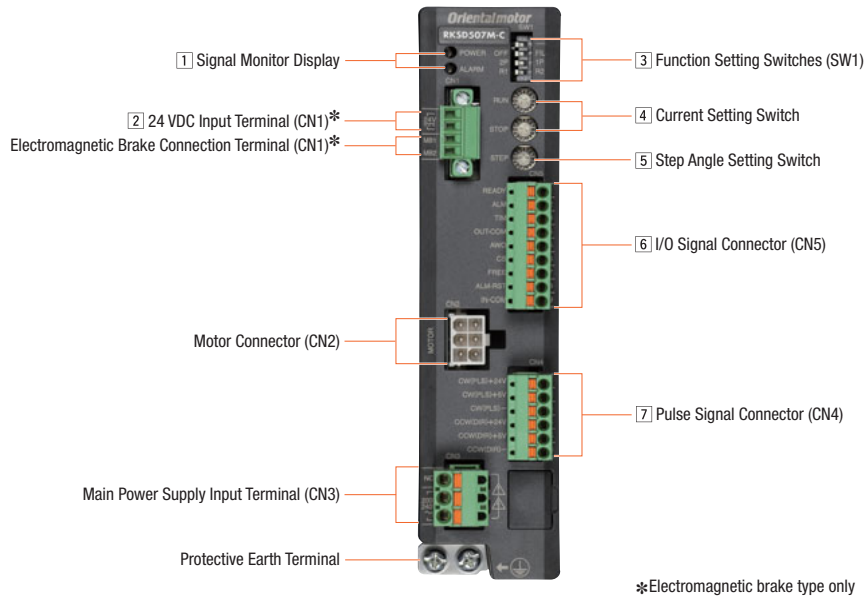

*Electromagnetic brake type only

1 Signal Monitor Display

◇ LED Indicator

Indication	Color	Function	Lighting Condition
POWER	Green	Power Supply Indication	When the main power supply is input
ALARM	Red	Alarm Indication	Blinks when protective functions are activated

◇ Alarm Contents

Blink Count	Function	Operating Condition	ALM-RST Release by Input	Motor Excitation
2	Main Circuit Overheating	The internal temperature of the driver exceeds 85°C	Yes	No holding
3	Overvoltage	The internal voltage of the driver exceeds the permissible value	No	
4	Command Pulse Abnormality	The value of the command pulse becomes abnormal	Yes	
5	Overcurrent	The motor, cable and driver output circuit shorted out	No	
6	Undervoltage	Power supply is instantaneously shut down Undervoltage	Yes	
7	Automatic Control of Electromagnetic Brake Abnormality	24 VDC power supply is not connected The electromagnetic brake is not connected The electromagnetic brake is mis-wired		
9	Electrolytic Capacitor Abnormality	The electrolytic capacitor of the main circuit is damaged	No	
	EEPROM Abnormality	The saved data of the driver is damaged		
Lighting	CPU Abnormality	CPU malfunctions		

2 24 VDC Power Supply Input Terminals/Electromagnetic Brake Connection Terminals

Indication	I/O	Terminal Name	Content
24 V+	Input	24 VDC Power Supply Input Terminal +	Connects the 24 VDC power for electromagnetic brake.
24 V-	Input	24 VDC Power Supply Input Terminal -	
MB1	Input	Electromagnetic Brake Connection Terminal - (Black)	Connect the electromagnetic brake wire of the motor with the electromagnetic brake.
MB2	Input	Electromagnetic Brake Connection Terminal + (White)	

Overview, Product Series

AC Input Motor & Driver

0.36°/Geared
αSTEP Absolute AZ

0.36°/Geared
αSTEP AR

0.72°/Geared
RKII

DC Input Motor & Driver

0.36°/Geared
αSTEP Absolute AZ

0.36°/Geared
αSTEP AR

1.8°/0.72°/0.36°
CVK

0.72°/0.36°/Geared
CRK

1.8°/Geared
RBK

Motor Only /Driver Only

1.8°/0.9°
PKP/PK

Geared
PKP/PK

0.72°/0.36°
PKP/PK

Driver

Accessories

3 Function Setting Switch (SW1)

Indication	No.	Function
R1/R2	1	Sets up the step angle in combination with the step angle setting switch.
2P/1P	2	Switches between 1-pulse input mode and 2-pulse input mode. [2P] for the 2-pulse input mode [1P] for the 1-pulse input mode (Factory setting)
OFF/FIL	3	Switches the responsiveness of the motor upon input of pulse.

● Difference in the Motor Responsiveness Depending on the Command Filter (OFF/FIL Switch)

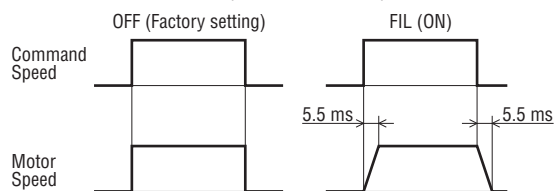

4 Current Setting Switch

Indication	Switch Name	Function
RUN	Operating Current Setting Switch	Sets the motor's operating current. The current value is set by the ratio of rated output current (%).
STOP	Stop Current Setting Switch	Sets the stopped current of the motor. The current value is set by the ratio of rated output current (%).

5 Step Angle Setting Switch

Indication	Function
STEP	Sets up step angle of the motor in combination with the function setting switch (SW1)

Function Setting Switch (SW1): R1			
Step Angle Setting Switch (STEP) Scale	Resolution [P/R]	Step Angle [°]	Microsteps/Step
0	500	0.72	1
1	1000	0.36	2
2	1250	0.288	2.5
3	2000	0.18	4
4	2500	0.144	5
5	4000	0.09	8
6	5000	0.072	10
7	10000	0.036	20
8	12500	0.0288	25
9	20000	0.018	40
A	25000	0.0144	50
B	40000	0.009	80
C	50000	0.0072	100
D	62500	0.00576	125
E	100000	0.0036	200
F	125000	0.00288	250

Function Setting Switch (SW1): R2			
Step Angle Setting Switch (STEP) Scale	Resolution [P/R]	Step Angle [°]	Microsteps/Step
0	200	1.8	0.4
1	400	0.9	0.8
2	600	0.6	1.2
3	800	0.45	1.6
4	1200	0.3	2.4
5	1600	0.225	3.2
6	3200	0.1125	6.4
7	6000	0.06	12
8	6400	0.05625	12.8
9	7200	0.05	14.4
A	8000	0.045	16
B	12000	0.03	24
C	12800	0.028125	25.6
D	16000	0.0225	32
E	25600	0.0140625	51.2
F	200000	0.0018	400

6 I/O Signal Connector (CN5)

Indication	I/O	Pin Number	Content
READY	Output	1	Outputs when operation of the driver has been prepared.
ALM		2	Output alarm status of the driver (normally closed).
TIM		3	Outputs when excitation state of the motor is at step "0" position.
OUT-COM		4	Output common
AW0	Input	5	Stops excitation of the motor.
CS		6	Switches the step angle.
FREE		7	Stops excitation of the motor. With electromagnetic brake type, the electromagnetic brake is also released.
ALM-RST		8	Resets the current alarm.
IN-COM		9	Input common

7 Pulse Signal Connector (CN4)

Indication	Pin Number	Content
PLS (CW) +24 V	1	Pulse Input (CW Pulse Input) [+24 V]
PLS (CW) +5 V	2	Pulse Input (CW Pulse Input) [+5 V or line driver]
PLS (CW) -	3	
DIR (CCW) +24 V	4	Rotation Direction Input (CCW Pulse Input) [+24 V]
DIR (CCW) +5 V	5	Rotation Direction Input (CCW Pulse Input) [+5 V or line driver]
DIR (CCW) -	6	

● Connection Diagram

◇ Connection with Peripheral Equipment

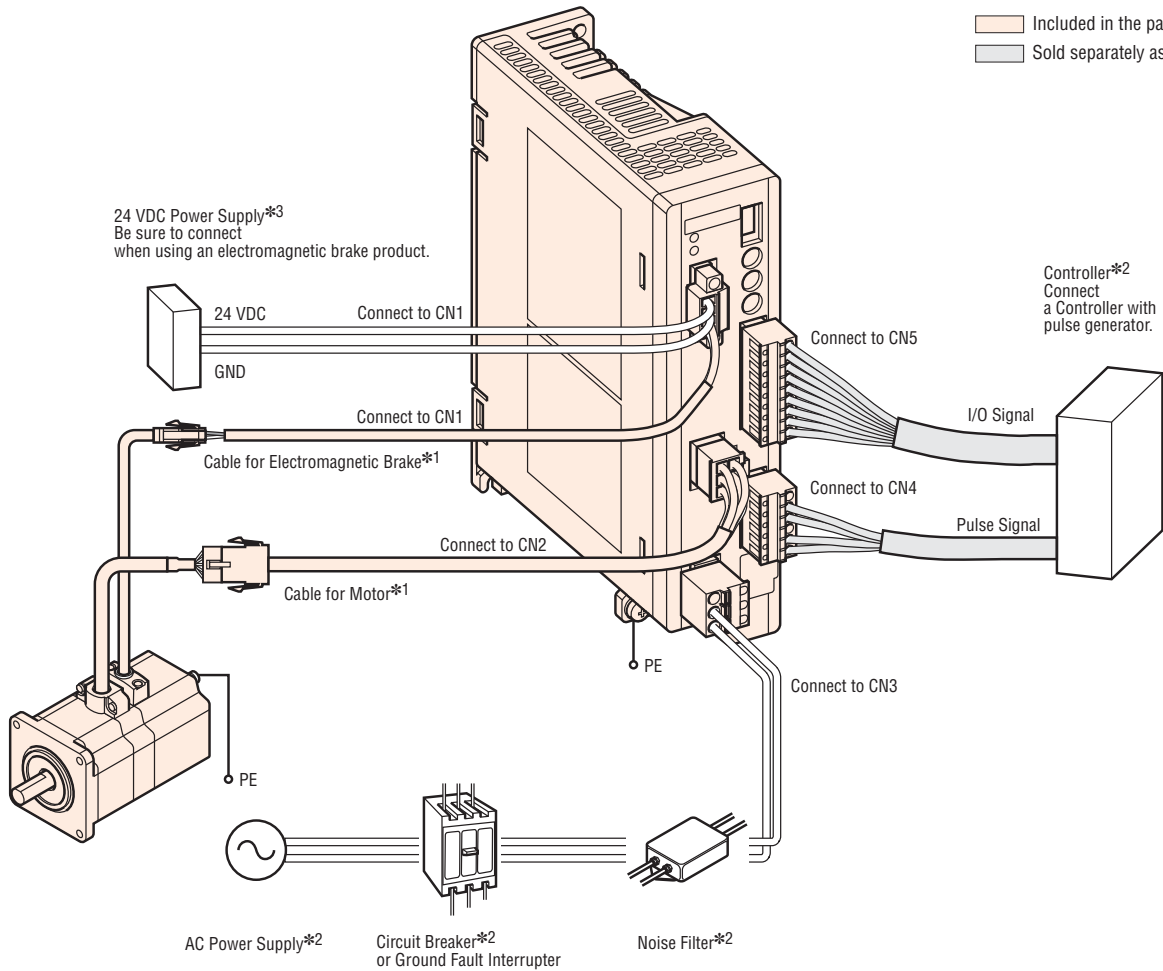

*1 Products are available with or without a 1 m, 2 m or 3 m cable that connects the motor and driver. If cables longer than 3 m or flexible cables are required, select the appropriate cables from the accessories (sold separately). When wiring the motor and the driver, keep a maximum distance of 20 m.

*2 Not Supplied.

*3 Not Supplied. If the wiring distance between the motor and driver is extended to 15 m or longer by using an accessory cable (Sold separately), the 24 VDC±4% specification applies.

Overview, Product Series

AC Input Motor & Driver

0.36°/Geared **αSTEP Absolute AZ**

0.36°/Geared **αSTEP AR**

0.72°/Geared **RK II**

DC Input Motor & Driver

0.36°/Geared **αSTEP Absolute AZ**

0.36°/Geared **αSTEP AR**

1.8°/0.72° /0.36° **CVK**

0.72°/0.36° /Geared **CRK**

1.8°/Geared **RBK**

Motor Only /Driver Only

1.8°/0.9° **PKP/PK**

Geared **PKP/PK**

0.72°/0.36° **PKP/PK**

Driver

Accessories

◇ Connection to a Host Controller

● Connecting to a Current Source Output Circuit

When pulse input is Line Driver

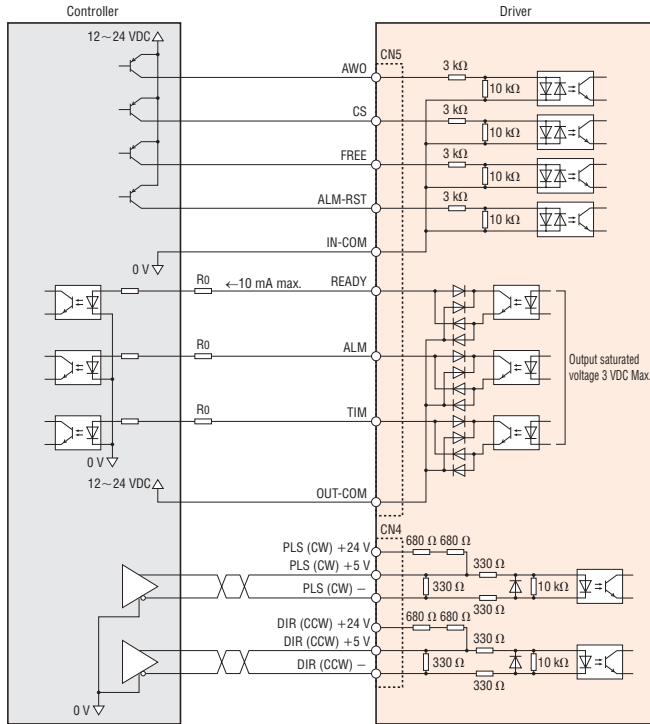

Note

- Use input signal at 12~24 VDC.
- Use output signal at 12~24 VDC 10 mA max. When the current value exceeds 10 mA, connect the external resistor R_o to keep 10 mA max.
- Output saturated voltage should be less than 3 VDC.
- Provide a minimum distance of 100 mm between the signal lines and power lines (Power supply lines, motor lines).
Do not run the signal lines in the same duct as power lines or bundle them with power lines.
- If noise generated by the motor cable or power supply cable causes a problem with the specific wiring or layout, shield the cable or use ferrite cores.

● Connection to a Current Sink Output Circuit

When pulse input is Line Driver

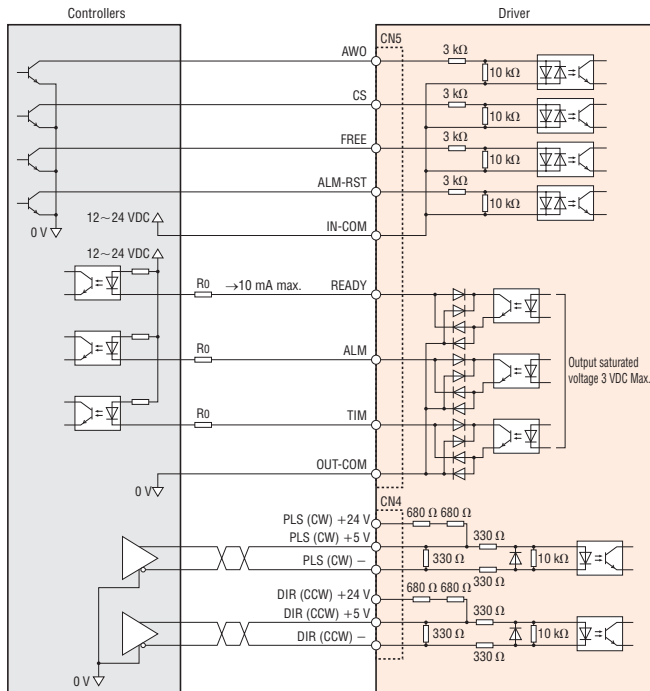

Note

- Use input signal at 12~24 VDC.
- Use output signal at 12~24 VDC 10 mA max. When the current value exceeds 10 mA, connect the external resistor R_o to keep 10 mA max.
- Output saturated voltage should be less than 3 VDC.
- Provide a minimum distance of 100 mm between the signal lines and power lines (Power supply lines, motor lines).
Do not run the signal lines in the same duct as power lines or bundle them with power lines.
- If noise generated by the motor cable or power supply cable causes a problem with the specific wiring or layout, shield the cable or use ferrite cores.

When the pulse input is open collector (Input voltage 5 VDC)

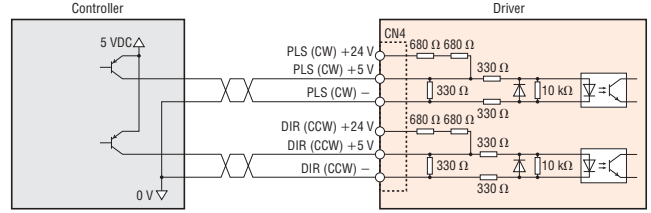

When the pulse input is open collector (Input voltage 24 VDC)

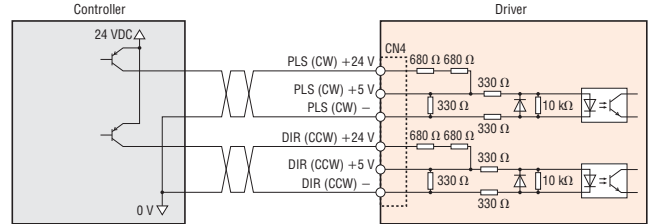

When the pulse input is open collector (Input voltage 5 VDC)

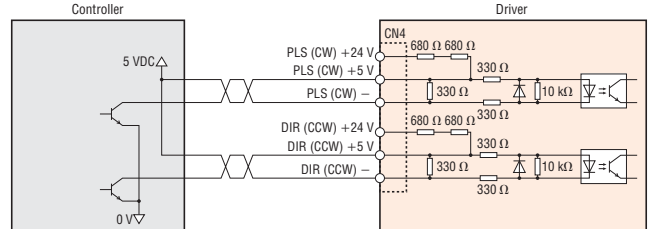

When the pulse input is open collector (Input voltage 24 VDC)

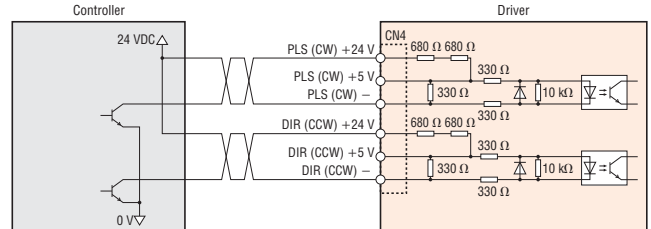

List of Motor and Driver Combinations

Product names for motor and driver combinations are shown below.

Built-in Controller Type

Type	Product Name	Motor Product Name	Driver Product Name	
Standard Type	RKS543□CD-◇	PKE543□C	RKSD503-CD	
	RKS544□CD-◇	PKE544□C		
	RKS545□CD-◇	PKE545□C		
	RKS564□CD-◇	PKE564□C		
	RKS566□CD-◇	PKE566□C		RKSD507-CD
	RKS569□CD-◇	PKE569□C		
	RKS596□CD-◇	PKE596□C		
	RKS599□CD-◇	PKE599□C		
RKS5913□CD-◇	PKE5913□C			
Standard Type with Electromagnetic Brake	RKS543MCD-◇	PKE543MC	RKSD503-CD	
	RKS544MCD-◇	PKE544MC		
	RKS545MCD-◇	PKE545MC		
	RKS564MCD-◇	PKE564MC		
	RKS566MCD-◇	PKE566MC		RKSD507-CD
	RKS569MCD-◇	PKE569MC		
	RKS596MCD-◇	PKE596MC		
	RKS599MCD-◇	PKE599MC		
RKS5913MCD-◇	PKE5913MC			
Standard Type with Encoder	RKS543RCD2-◇	PKE543RC2	RKSD503-CD	
	RKS544RCD2-◇	PKE544RC2		
	RKS545RCD2-◇	PKE545RC2		
	RKS564RCD2-◇	PKE564RC2		
	RKS566RCD2-◇	PKE566RC2		RKSD507-CD
	RKS569RCD2-◇	PKE569RC2		
	RKS596RCD2-◇	PKE596RC2		
	RKS599RCD2-◇	PKE599RC2		
RKS5913RCD2-◇	PKE5913RC2			
TS Geared Type	RKS543□CD-TS3.6-◇	PKE543□C-TS3.6	RKSD503-CD	
	RKS543□CD-TS7.2-◇	PKE543□C-TS7.2		
	RKS543□CD-TS10-◇	PKE543□C-TS10		
	RKS543□CD-TS20-◇	PKE543□C-TS20		
	RKS543□CD-TS30-◇	PKE543□C-TS30		
	RKS564□CD-TS3.6-◇	PKE564□C-TS3.6		
	RKS564□CD-TS7.2-◇	PKE564□C-TS7.2		
	RKS564□CD-TS10-◇	PKE564□C-TS10		
	RKS564□CD-TS20-◇	PKE564□C-TS20		
	RKS564□CD-TS30-◇	PKE564□C-TS30	RKSD507-CD	
	RKS596□CD-TS3.6-◇	PKE596□C-TS3.6		
	RKS596□CD-TS7.2-◇	PKE596□C-TS7.2		
	RKS596□CD-TS10-◇	PKE596□C-TS10		
	RKS596□CD-TS20-◇	PKE596□C-TS20		
	RKS596□CD-TS30-◇	PKE596□C-TS30		
	RKS543MCD-TS3.6-◇	PKE543MC-TS3.6		RKSD503-CD
RKS543MCD-TS7.2-◇	PKE543MC-TS7.2			
RKS543MCD-TS10-◇	PKE543MC-TS10			
RKS543MCD-TS20-◇	PKE543MC-TS20			
RKS543MCD-TS30-◇	PKE543MC-TS30			
RKS564MCD-TS3.6-◇	PKE564MC-TS3.6			
RKS564MCD-TS7.2-◇	PKE564MC-TS7.2			
RKS564MCD-TS10-◇	PKE564MC-TS10			
RKS564MCD-TS20-◇	PKE564MC-TS20	RKSD507-CD		
RKS564MCD-TS30-◇	PKE564MC-TS30			
RKS596MCD-TS3.6-◇	PKE596MC-TS3.6			
RKS596MCD-TS7.2-◇	PKE596MC-TS7.2			
RKS596MCD-TS10-◇	PKE596MC-TS10			
RKS596MCD-TS20-◇	PKE596MC-TS20			
RKS596MCD-TS30-◇	PKE596MC-TS30			

● Enter **A** (Single shaft) or **B** (Double shaft) where the box □ is located within the product name.

For products that include a connection cable, a number indicating the cable length, **1** (1 m), **2** (2 m) or **3** (3 m) is specified where the box ◇ is located in the product name.

If no connection cable is included, there will be no "◇" within the product name.

Overview,
Product
Series

AC Input
Motor &
Driver

0.36°/Geared
αSTEP
Absolute
AZ

0.36°/Geared
αSTEP
AR

0.72°/Geared
RKII

DC Input
Motor &
Driver

0.36°/Geared
αSTEP
Absolute
AZ

0.36°/Geared
αSTEP
AR

1.8°/0.72°
/0.36°
CVK

0.72°/0.36°
/Geared
CRK

1.8°/Geared
RBK

Motor Only
/Driver Only

1.8°/0.9°
PKP/PK

Geared
PKP/PK

0.72°/0.36°
PKP/PK

Driver

Accessories

Type	Product Name	Motor Product Name	Driver Product Name
PS Geared Type	RKS545□CD-PS5-◇	PKE545□C-PS5	RKSD503-CD
	RKS545□CD-PS7.2-◇	PKE545□C-PS7.2	
	RKS545□CD-PS10-◇	PKE545□C-PS10	
	RKS543□CD-PS25-◇	PKE543□C-PS25	
	RKS543□CD-PS36-◇	PKE543□C-PS36	
	RKS543□CD-PS50-◇	PKE543□C-PS50	
	RKS566□CD-PS5-◇	PKE566□C-PS5	RKSD507-CD
	RKS566□CD-PS7.2-◇	PKE566□C-PS7.2	
	RKS566□CD-PS10-◇	PKE566□C-PS10	
	RKS564□CD-PS25-◇	PKE564□C-PS25	
	RKS564□CD-PS36-◇	PKE564□C-PS36	
	RKS564□CD-PS50-◇	PKE564□C-PS50	
	RKS599□CD-PS5-◇	PKE599□C-PS5	
	RKS599□CD-PS7.2-◇	PKE599□C-PS7.2	
RKS599□CD-PS10-◇	PKE599□C-PS10		
RKS596□CD-PS25-◇	PKE596□C-PS25		
RKS596□CD-PS36-◇	PKE596□C-PS36		
RKS596□CD-PS50-◇	PKE596□C-PS50		
PS Geared Type with Electromagnetic Brake	RKS545MCD-PS5-◇	PKE545MC-PS5	RKSD503-CD
	RKS545MCD-PS7.2-◇	PKE545MC-PS7.2	
	RKS545MCD-PS10-◇	PKE545MC-PS10	
	RKS543MCD-PS25-◇	PKE543MC-PS25	
	RKS543MCD-PS36-◇	PKE543MC-PS36	
	RKS543MCD-PS50-◇	PKE543MC-PS50	
	RKS566MCD-PS5-◇	PKE566MC-PS5	RKSD507-CD
	RKS566MCD-PS7.2-◇	PKE566MC-PS7.2	
	RKS566MCD-PS10-◇	PKE566MC-PS10	
	RKS564MCD-PS25-◇	PKE564MC-PS25	
	RKS564MCD-PS36-◇	PKE564MC-PS36	
	RKS564MCD-PS50-◇	PKE564MC-PS50	
	RKS599MCD-PS5-◇	PKE599MC-PS5	
	RKS599MCD-PS7.2-◇	PKE599MC-PS7.2	
RKS599MCD-PS10-◇	PKE599MC-PS10		
RKS596MCD-PS25-◇	PKE596MC-PS25		
RKS596MCD-PS36-◇	PKE596MC-PS36		
RKS596MCD-PS50-◇	PKE596MC-PS50		
Harmonic Geared Type	RKS543□CD-HS50-◇	PKE543□C-HS50	RKSD503-CD
	RKS543□CD-HS100-◇	PKE543□C-HS100	
	RKS564□CD-HS50-◇	PKE564□C-HS50	RKSD507-CD
	RKS564□CD-HS100-◇	PKE564□C-HS100	
	RKS596□CD-HS50-◇	PKE596□C-HS50	
RKS596□CD-HS100-◇	PKE596□C-HS100		
Harmonic Geared Type with Electromagnetic Brake	RKS543MCD-HS50-◇	PKE543MC-HS50	RKSD503-CD
	RKS543MCD-HS100-◇	PKE543MC-HS100	
	RKS564MCD-HS50-◇	PKE564MC-HS50	RKSD507-CD
	RKS564MCD-HS100-◇	PKE564MC-HS100	
	RKS596MCD-HS50-◇	PKE596MC-HS50	
RKS596MCD-HS100-◇	PKE596MC-HS100		

● Enter **A** (Single shaft) or **B** (Double shaft) where the box □ is located within the product name.

For products that include a connection cable, a number indicating the cable length, **1** (1 m), **2** (2 m) or **3** (3 m) is specified where the box ◇ is located in the product name.

If no connection cable is included, there will be no "-◇" within the product name.

● Pulse Input Type

Type	Product Name	Motor Product Name	Driver Product Name
Standard Type	RKS543□C-◇	PKE543□C	RKSD503-C
	RKS544□C-◇	PKE544□C	
	RKS545□C-◇	PKE545□C	
	RKS564□C-◇	PKE564□C	
	RKS566□C-◇	PKE566□C	RKSD507-C
	RKS569□C-◇	PKE569□C	
	RKS596□C-◇	PKE596□C	
	RKS599□C-◇	PKE599□C	
RKS5913□C-◇	PKE5913□C		
Standard Type with Electromagnetic Brake	RKS543MC-◇	PKE543MC	RKSD503M-C
	RKS544MC-◇	PKE544MC	
	RKS545MC-◇	PKE545MC	
	RKS564MC-◇	PKE564MC	
	RKS566MC-◇	PKE566MC	RKSD507M-C
	RKS569MC-◇	PKE569MC	
	RKS596MC-◇	PKE596MC	
	RKS599MC-◇	PKE599MC	
RKS5913MC-◇	PKE5913MC		
TS Geared Type	RKS543□C-TS3.6-◇	PKE543□C-TS3.6	RKSD503-C
	RKS543□C-TS7.2-◇	PKE543□C-TS7.2	
	RKS543□C-TS10-◇	PKE543□C-TS10	
	RKS543□C-TS20-◇	PKE543□C-TS20	
	RKS564□C-TS3.6-◇	PKE564□C-TS3.6	RKSD507-C
	RKS564□C-TS7.2-◇	PKE564□C-TS7.2	
	RKS564□C-TS10-◇	PKE564□C-TS10	
	RKS564□C-TS20-◇	PKE564□C-TS20	
	RKS564□C-TS30-◇	PKE564□C-TS30	
	RKS596□C-TS3.6-◇	PKE596□C-TS3.6	
	RKS596□C-TS7.2-◇	PKE596□C-TS7.2	
	RKS596□C-TS10-◇	PKE596□C-TS10	
	RKS596□C-TS20-◇	PKE596□C-TS20	
	RKS596□C-TS30-◇	PKE596□C-TS30	
TS Geared Type with Electromagnetic Brake	RKS543MC-TS3.6-◇	PKE543MC-TS3.6	RKSD503M-C
	RKS543MC-TS7.2-◇	PKE543MC-TS7.2	
	RKS543MC-TS10-◇	PKE543MC-TS10	
	RKS543MC-TS20-◇	PKE543MC-TS20	
	RKS564MC-TS3.6-◇	PKE564MC-TS3.6	RKSD507M-C
	RKS564MC-TS7.2-◇	PKE564MC-TS7.2	
	RKS564MC-TS10-◇	PKE564MC-TS10	
	RKS564MC-TS20-◇	PKE564MC-TS20	
	RKS564MC-TS30-◇	PKE564MC-TS30	
	RKS596MC-TS3.6-◇	PKE596MC-TS3.6	
	RKS596MC-TS7.2-◇	PKE596MC-TS7.2	
	RKS596MC-TS10-◇	PKE596MC-TS10	
	RKS596MC-TS20-◇	PKE596MC-TS20	
	RKS596MC-TS30-◇	PKE596MC-TS30	

● Enter **A** (Single shaft) or **B** (Double shaft) where the box □ is located within the product name.

For products that include a connection cable, a number indicating the cable length, **1** (1 m), **2** (2 m) or **3** (3 m) is specified where the box ◇ is located in the product name.

If no connection cable is included, there will be no "◇" within the product name.

Overview, Product Series

AC Input Motor & Driver

0.36°/Geared **αSTEP Absolute AZ**

0.36°/Geared **αSTEP AR**

0.72°/Geared **RKII**

DC Input Motor & Driver

0.36°/Geared **αSTEP Absolute AZ**

0.36°/Geared **αSTEP AR**

1.8°/0.72°/0.36° **CVK**

0.72°/0.36°/Geared **CRK**

1.8°/Geared **RBK**

Motor Only /Driver Only

1.8°/0.9° **PKP/PK**

Geared **PKP/PK**

0.72°/0.36° **PKP/PK**

Driver

Accessories

Type	Product Name	Motor Product Name	Driver Product Name
PS Geared Type	RKS545□C-PS5-◇	PKE545□C-PS5	RKSD503-C
	RKS545□C-PS7.2-◇	PKE545□C-PS7.2	
	RKS545□C-PS10-◇	PKE545□C-PS10	
	RKS543□C-PS25-◇	PKE543□C-PS25	
	RKS543□C-PS36-◇	PKE543□C-PS36	
	RKS543□C-PS50-◇	PKE543□C-PS50	
	RKS566□C-PS5-◇	PKE566□C-PS5	RKSD507-C
	RKS566□C-PS7.2-◇	PKE566□C-PS7.2	
	RKS566□C-PS10-◇	PKE566□C-PS10	
	RKS564□C-PS25-◇	PKE564□C-PS25	
	RKS564□C-PS36-◇	PKE564□C-PS36	
	RKS564□C-PS50-◇	PKE564□C-PS50	
	RKS599□C-PS5-◇	PKE599□C-PS5	
	RKS599□C-PS7.2-◇	PKE599□C-PS7.2	
RKS599□C-PS10-◇	PKE599□C-PS10		
RKS596□C-PS25-◇	PKE596□C-PS25		
RKS596□C-PS36-◇	PKE596□C-PS36		
RKS596□C-PS50-◇	PKE596□C-PS50		
PS Geared Type with Electromagnetic Brake	RKS545MC-PS5-◇	PKE545MC-PS5	RKSD503M-C
	RKS545MC-PS7.2-◇	PKE545MC-PS7.2	
	RKS545MC-PS10-◇	PKE545MC-PS10	
	RKS543MC-PS25-◇	PKE543MC-PS25	
	RKS543MC-PS36-◇	PKE543MC-PS36	
	RKS543MC-PS50-◇	PKE543MC-PS50	
	RKS566MC-PS5-◇	PKE566MC-PS5	RKSD507M-C
	RKS566MC-PS7.2-◇	PKE566MC-PS7.2	
	RKS566MC-PS10-◇	PKE566MC-PS10	
	RKS564MC-PS25-◇	PKE564MC-PS25	
	RKS564MC-PS36-◇	PKE564MC-PS36	
	RKS564MC-PS50-◇	PKE564MC-PS50	
	RKS599MC-PS5-◇	PKE599MC-PS5	
	RKS599MC-PS7.2-◇	PKE599MC-PS7.2	
RKS599MC-PS10-◇	PKE599MC-PS10		
RKS596MC-PS25-◇	PKE596MC-PS25		
RKS596MC-PS36-◇	PKE596MC-PS36		
RKS596MC-PS50-◇	PKE596MC-PS50		
Harmonic Geared Type	RKS543□C-HS50-◇	PKE543□C-HS50	RKSD503-C
	RKS543□C-HS100-◇	PKE543□C-HS100	
	RKS564□C-HS50-◇	PKE564□C-HS50	RKSD507-C
	RKS564□C-HS100-◇	PKE564□C-HS100	
	RKS596□C-HS50-◇	PKE596□C-HS50	
RKS596□C-HS100-◇	PKE596□C-HS100		
Harmonic Geared Type with Electromagnetic Brake	RKS543MC-HS50-◇	PKE543MC-HS50	RKSD503M-C
	RKS543MC-HS100-◇	PKE543MC-HS100	
	RKS564MC-HS50-◇	PKE564MC-HS50	RKSD507M-C
	RKS564MC-HS100-◇	PKE564MC-HS100	
	RKS596MC-HS50-◇	PKE596MC-HS50	
RKS596MC-HS100-◇	PKE596MC-HS100		

● Enter **A** (Single shaft) or **B** (Double shaft) where the box □ is located within the product name.

For products that include a connection cable, a number indicating the cable length, **1** (1 m), **2** (2 m) or **3** (3 m) is specified where the box ◇ is located in the product name.

If no connection cable is included, there will be no "-◇" within the product name.