



Electric Swing Clamps

Top flange, with position and clamping force monitoring,
 DC voltage 24 V, minimum energy demand



Application

Electric swing clamps are used for clamping or holding of workpieces

- where the use of hydraulic clamping elements is not possible
- where the clamping force must be maintained also after the separation from the energy supply
- when clamping elements have to be controlled individually
- when an extended functionality is required for automated systems
- when the clamping and holding points shall be free for loading and unloading of the fixture

Electric swing clamps are particularly suited for:

- Packaging industry
- Test systems
- Special machines
- Assembly equipments and robotics
- Automatic manufacturing systems
- Clamping fixtures with workpiece loading via handling systems

Important notes!

Electric swing clamps are designed exclusively for clamping or holding of workpieces in industrial applications. They can generate very high clamping forces. The workpiece, the fixture or the machine must be in the position to compensate these forces.

In the effective area of piston rod and clamping arm there is the danger of crushing.

The manufacturer of the fixture or the machine is obliged to provide effective protection devices. During loading and unloading of the fixture and during clamping a collision with the clamping arm has to be avoided.

For the positioning of workpieces, the admissible displacement force as per diagram on page 3 has to be considered.

If there is any danger that fluids penetrate into the electric swing clamp, the screw plug at the venting port G 1/8 has to be removed and a vent hose has to be connected. The other end of the hose has to be placed to an absolutely dry area.

It is recommended to connect a dry positive air pressure protection with 0.2 bar.

Advantages

- High clamping force
- Adjustable clamping force
- Clamping force monitoring (error code output)
- Can be controlled individually or in common
- High operating safety by self-locking spindle drive
- Mechanical reclamping by Belleville springs
- Swing angle up to 180° available
- Overload protection device in the case of collisions with the clamping arm
- Electric position monitoring and extensive self-monitoring with error message
- Clamping stroke control possible
- Low voltage 24 V
- Leakage free
- Maintenance free (500,000 cycles).
- Code class IP 67

Description

The electric swing clamp is driven by a wear-resistant brushless DC motor. The motor speed is transformed by means of a gear and a threaded spindle into the swing and stroke movement of the piston rod. For swinging the clamping arm by 180°, an axial stroke of only 3 mm is required.

If the clamping arm collides during the swing motion with a workpiece, the mechanism is protected against overload. The direct current motor is automatically and immediately switched off. When unclamping, the clamping arm always swings back to the off-position.

Power supply

For motor and electronic control a DC voltage of 24 V with a residual ripple of max. 10 % is required.

For the DC motor, we recommend the use of a switching power supply with a current output of 15 A per connected electric swing clamp. When operating several swing clamps at the same time, the line is to be enlarged correspondingly. The electronic control has to be supplied by a separate power supply (24 V DC/100 mA).

Integrated control

The electronic control for the DC motor is on a board in the housing of the electric swing clamp.

Electric connection

Power supply and signal exchange for external control are transmitted via two short cables with plug-type connector. Cable sockets are available for the customer's connection (see accessories).

Not dangerous touch voltage

The used DC voltage 24 V is considered to be a "low voltage" and thus it is not dangerous for people in case of contact.

Functional principle

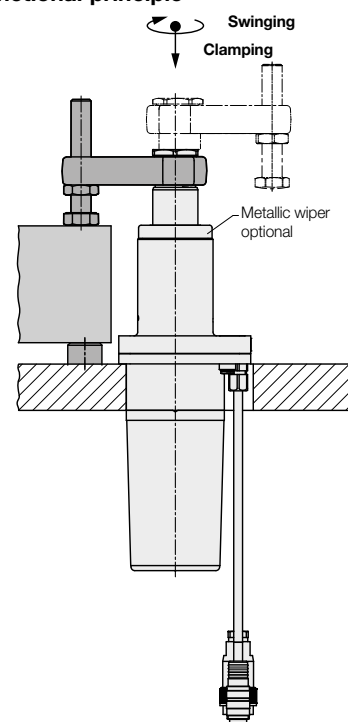

Adjusting ranges

After removal of the protection cover, the following adjustments can be made on the control board:

- Clamping force
- Swing speed
- Compensation of the clamping arm elasticity

The clamping force can also be adjusted via analogue input.

Function control

Unclamped

- Clamping arm in off-position and unclamping process completed

Clamped

- Clamping arm within clamping area and clamping force obtained
- Clamping stroke control possible by analogue output signal

Error messages

- Extensive review on error conditions
- Signalling via error code (flashing signal) internally on control board or via external interface signal
- Error messages can be reset
- Review display after 500,000 cycles

You will find a complete description in the supplied operating manual.

Technical information

Further information on the application and operating conditions is available on request.

Dimensions Technical data

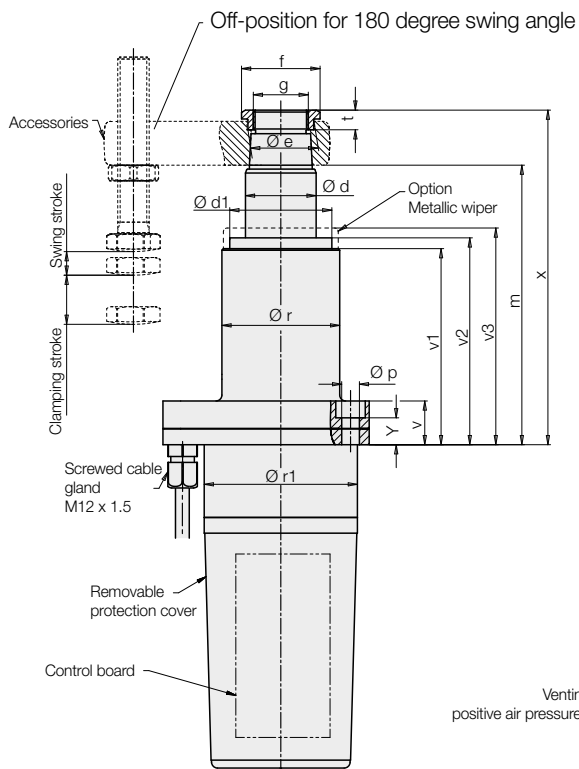

View X

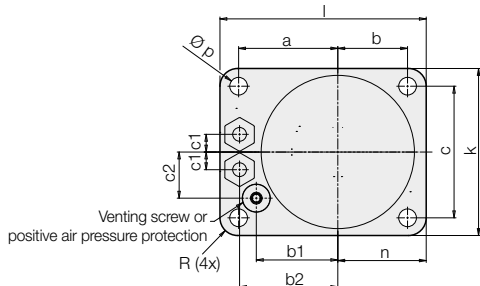

Clamping arm can be fixed in any desired position.

Clamping position $\pm 1^\circ$

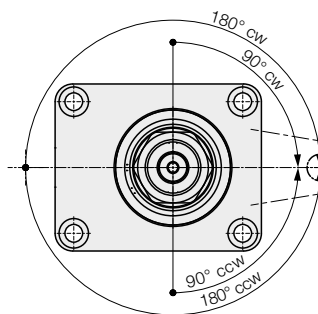

Collar nut included in the delivery
Spare nut see page 4

Option
Metallic wiper

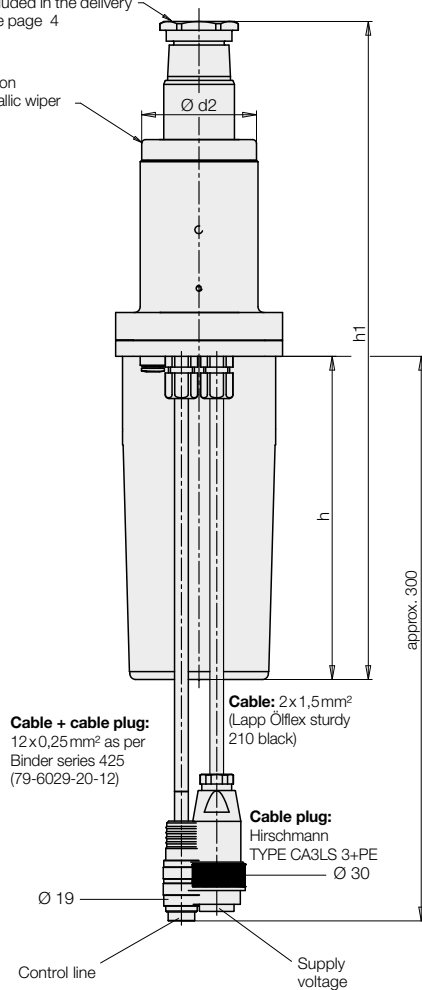

Accessories see page 4

Connecting scheme

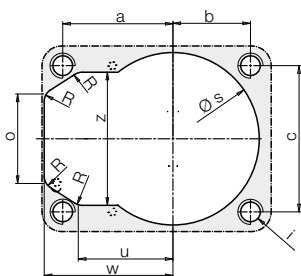

Connecting example (minimum configuration)

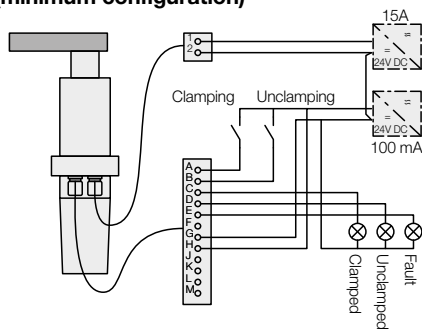

Connecting example with programmable logic control (PLC) and further technical characteristics and descriptions see technical information "Electric swing clamp".

Pin assignment

Supply voltage 24 VDC - 15A

Pin	Function
1	+24VDC
2	Ground (GND)

Control line

Pin Function

Pin	Function
A	Command clamping
B	Command unclamping
C	Message clamped
D	Message unclamped
E	Message number of cycles
F	Message error code
G	GND (control)
H	+24VDC (control)
K	Command error reset
L	Analogue input clamping force (0–10 V)
M	Analogue output clamping stroke (0–10 V)

Important notes

For cable lengths of more than 10 m or electromagnetic interference, the cables must be shielded. The shielding must be grounded on the control side
The connecting cables should be laid and fixed so that damages are excluded.

Connecting cable

for control	12 x 0.25 mm ²
for supply of the DC motor	
Cable length	Cable cross section
< 7 m	2 x 1 mm ²
< 12 m	2 x 1.5 mm ²
< 20 m	2 x 2.5 mm ²
< 30 m	2 x 4 mm ²

Dimensions Technical data

Electric swing clamps		1835
Axial pulling force adjustable	[kN]	3...9
Effective clamping force	[kN]	see diagram
Admissible displacement force	[kN]	see diagram
Clamping stroke (usable)	[mm]	20
Swing stroke	[mm]	3
Total stroke (mechanical)	[mm]	26
Swing angle	[°]	0°/90°/180°*
Clamping time approx.	[s]	3**
Unclamping time approx.	[s]	3**
Special clamping arm		
Max. clamping arm length	[mm]	150
Max. radial torque	[Nm]	0.4
Max. moment of inertia	[kgm ²]	0.012
Nominal voltage	[V DC]	24
Operating range	[V DC]	22...30
Residual ripple	[%]	< 10
Max. current consumption	[A]	15
Power consumption in standby mode approx.	[W]	1.2
Duty cycle	[%]	25 (S3)
Code class		IP 67
Positive air pressure connection max.	[bar]	0.2
Ambient temperature	[°C]	-10 ... +40
Mounting position		preferably vertical***
Weight, approx.	[kg]	8
a	[mm]	50.5
b	[mm]	35.5
b1	[mm]	41.5
b2	[mm]	50
c	[mm]	67
c1	[mm]	9
c2	[mm]	23.5
Ø d	[mm]	36
Ø d1	[mm]	52
Ø d2	[mm]	58.5
Ø e	[mm]	33.5
f	[mm]	40
g	[mm]	M28 x 1.5
h	[mm]	164.5
h1	[mm]	334
i	[mm]	M8
k	[mm]	85
l	[mm]	105
m - 1	[mm]	142
n	[mm]	45
o	[mm]	41
Ø p	[mm]	9
Ø r - 0.1	[mm]	60
Ø r 1	[mm]	78
R max.	[mm]	6
Ø s ± 0.5	[mm]	79
t	[mm]	10
u	[mm]	43.4
v	[mm]	22
v1	[mm]	99.5
v2	[mm]	105
v3	[mm]	110
w	[mm]	59
x	[mm]	170
y	[mm]	13.5
z	[mm]	61
Part no.		
Swing direction 90° clockwise		1835-B090-R26M
Swing direction 90° counterclockwise		1835-B090-L26M
Swing direction 180° clockwise		1835-B180-R26M
Swing direction 180° counterclockwise		1835-B180-L26M
0 degree		1835-B000-026M

M = Option metallic wiper

* Further swing angles are available on request (min. 45°).

** Further technical data are available on request

*** For horizontal mounting position, please note page 4.

Accessories

Cable socket Binder 423 12 POL.

Part no. 3141-992



Cable socket Hirschmann CA3LD

Part no. 3141-991



Effective clamping force F_{Sp} as a function of the clamping arm length L

The effective clamping force is smaller the longer the clamping arm. For longer clamping arms, the clamping force must be reduced so that the admissible bending moment will not be exceeded.

The adjustment of the clamping force is made on the control board or externally via the analogue input L.

The default setting of 6.9 kN is suitable for the accessory clamping arm $L = 75$ mm.

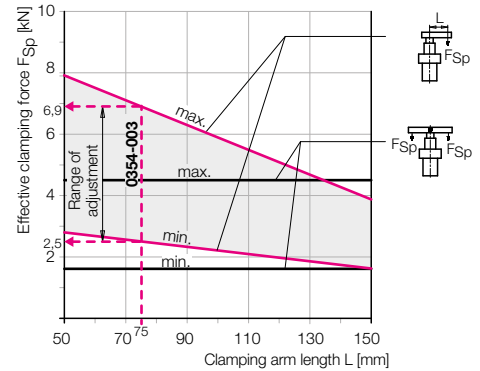

Example

Accessory clamping arm 0354-003: $L = 75$ mm

As per diagram:

- max. clamping force 6.9 kN
- min. clamping force 2.5 kN

If required, the clamping force can be reduced in 9 steps up to 2.5 kN.

Admissible displacement force F_v for the horizontal positioning of a workpiece

The electric swing clamp can push, i.e. position a workpiece against fixed points.

The usable displacement force F_v is depending on the clamping arm length between 0.7 and 1.1 kN.

Conditions:

For functional reasons, the clamping force F_{Sp} must be adjusted for the subsequent clamping of the workpiece with the accessory clamping arm ($L = 75$ mm) to at least 4.5 kN.

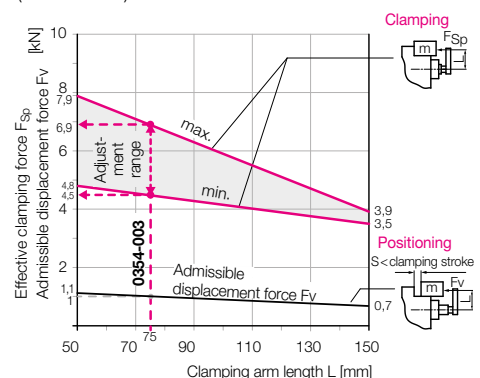

Example

Accessory clamping arm 0354-003: $L = 75$ mm

As per diagram:

- Min. clamping force 4.5 kN
- Max. clamping force 6.9 kN
- Displacement force F_v 1.0 kN

With a friction coefficient $\mu = 0.4$, this is sufficient for a workpiece mass m :

$$m = \frac{F_v}{g \cdot \mu} = \frac{1000 \text{ N}}{9.81 \cdot 0.4} = 250 \text{ kg}$$

Dimensions for special clamping arms

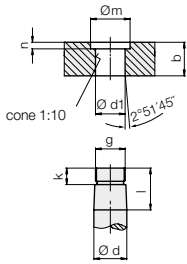

Clamping arm with contact bolt

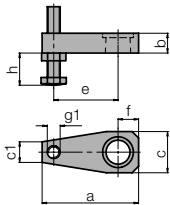

Clamping arm without thread g1

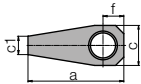

Clamping arm blank

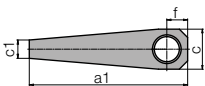

Double clamping arm complete with carrier
GGG 40

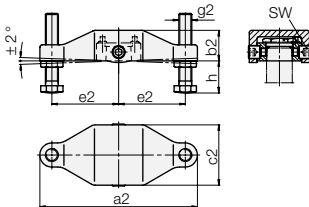

Carrier for double clamping arm
42CrV4 hardened and tempered

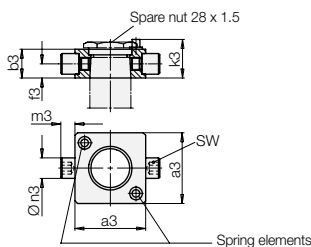

Horizontal mounting position

The electric swing clamp can be operated with the accessory clamping arm 0354-003 (e = 75 mm) in every mounting position.

In the case of longer and heavier special clamping arms, the admissible radial torque of 0.4 Nm will be exceeded, which can lead to malfunctions and increased wear.

Remedy:

Provide the clamping arm with a counterweight as explained in the opposite example.

Electric swing clamps

		1835
a	[mm]	115
a1	[mm]	190
a2	[mm]	196
a3 ±0.1	[mm]	55
b	[mm]	23
b2	[mm]	38
b3 ±0.1	[mm]	23
c	[mm]	48
c1	[mm]	22
c2	[mm]	75
Ød f7	[mm]	32
Ød1 +0.05	[mm]	31.85
e	[mm]	75
e2	[mm]	83
f	[mm]	25
f3	[mm]	11
g	[mm]	M28x1.5
g1	[mm]	M16
g2	[mm]	M16
h min...max	[mm]	15...79
k	[mm]	12
k3**	[mm]	29
l	[mm]	28
Ø m	[mm]	34
m3	[mm]	11
n	[mm]	5
Ø n3 g6	[mm]	16
Ø p	[mm]	90
Ø q -0.2	[mm]	68
r	[mm]	M60x1.5
s	[mm]	13
t	[mm]	4
SW	[mm]	8

Part no.

Clamping arm with contact bolt

Weight, approx.	[kg]	0.8
Moment of inertia	[kgm ²]	0.002295
Radial torque	[Nm]	0.32

Clamping arm without thread g1

Weight, approx.	[kg]	0.65
Moment of inertia	[kgm ²]	0.00134
Radial torque	[Nm]	0.20

Clamping arm blank

Weight, approx.	[kg]	1.15
Moment of inertia	[kgm ²]	0.00798
Radial torque	[Nm]	0.74

Material: High alloy steel 1000....1200 N/mm²

Double clamping arm, complete*

Weight, approx.	[kg]	2
Moment of inertia	[kg·m ²]	0.00765

Carrier for double clamping arm

Weight, approx.	[kg]	0.46
-----------------	------	------

Spare nut M 28 x 1.5

Max. tightening torque	[Nm]	90
------------------------	------	----

Weight, approx.	[kg]	0.05
-----------------	------	------

Metallic wiper

		0341-231
--	--	----------

- * Complete with threaded bolt and spring elements
- ** Height stop surface for spring elements

Clamping arm with weight compensation

$$\text{Required counterweight } m_2 = \frac{M_1}{l_2} \quad [\text{kg}]$$

M₁ = First-order torque around the piston axis (control of the CAD model) [kgm]

m₂ = Mass of counterweight [kg]

l₂ = Centre of gravity of the mass m₂ [m]

Important note

The additional counterweight increases the moment of inertia J around the piston axis, what can be easily determined by querying of the CAD model. To avoid an overload of the swing drive, the flow rate has to be reduced: The setting is described in the operating manual.

Mounting position - horizontal

