

# INSTRUCTIONS–PARTS LIST

**VERDER**

CONDUCTIVE POLYPROPYLENE, POLYPROPYLENE AND PVDF

## **VERDERAIR VA 50**

# Air-Operated Diaphragm Pumps

**819.4496**

Rev. ZAB  
EN

***For fluid transfer applications. For professional use only.***

8.3 bar Maximum Fluid Working Pressure

8.3 bar Maximum Air Input Pressure



### **Important Safety Instructions**

Read all warnings and instructions in the manual. Save these instructions.

**\*NOTE:** Refer to the Pump Listing on page 22 to determine the Model No. of your pump.

Patent No.  
CN ZL941026434.4  
FR 9408894  
JA 35107270  
US 5,368,452

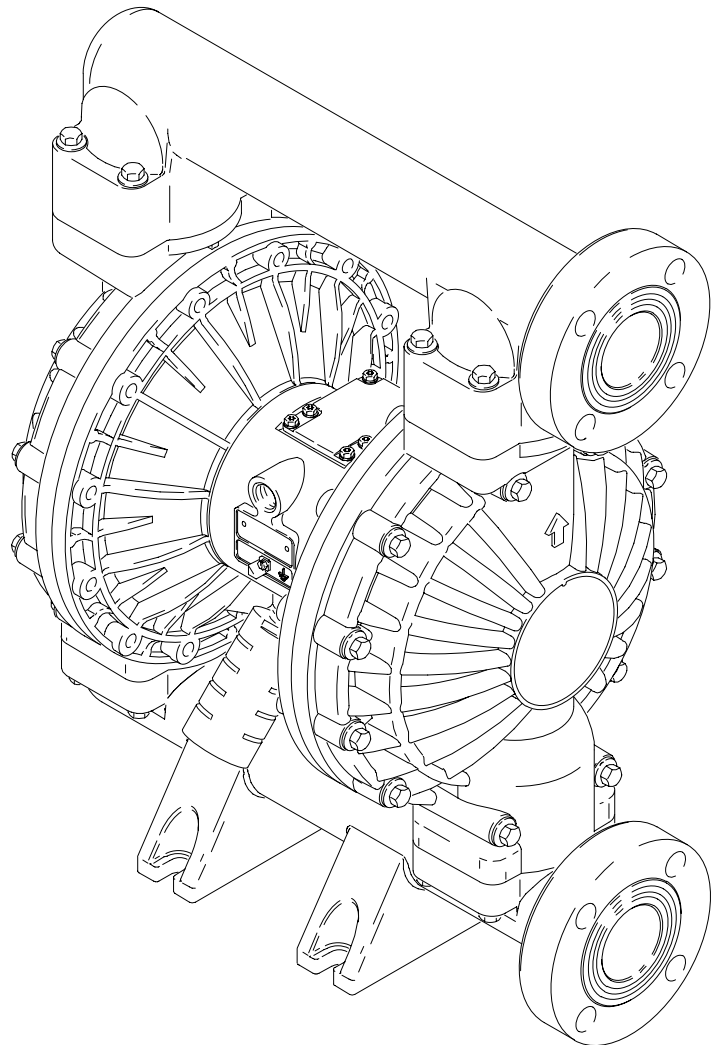

II 2 GD c IIC T4



HO03

\* Applies only to pumps with conductive polypropylene fluid sections.

04613B

## Table of Contents

Safety Warnings .....	2
Installation .....	4
Operation .....	11
Maintenance .....	12
Troubleshooting .....	13
Service	
Repairing the Air Valve .....	14
Ball Check Valve Repair .....	16
Diaphragm Repair .....	17
Bearing and Air Gasket Removal .....	20
Pump Listing .....	22
Repair Kit Listing .....	23
Parts .....	24
Torque Sequence .....	28
Dimensions .....	29
Technical Data and Performance Chart .....	30
Customer/Guarantee .....	31

## Symbols

### Warning Symbol



This symbol alerts you to the possibility of serious injury or death if you do not follow the instructions.

### Caution Symbol



This symbol alerts you to the possibility of damage to or destruction of equipment if you do not follow the instructions.

## Warning



INSTRUCTIONS

### EQUIPMENT MISUSE HAZARD

Equipment misuse can cause the equipment to rupture or malfunction and result in serious injury.

- This equipment is for professional use only.
- Read all instruction manuals, tags, and labels before operating the equipment.
- Use the equipment only for its intended purpose. If you are not sure, call VERDER After Sales Service.
- Do not alter or modify this equipment.
- Check equipment daily. Repair or replace worn or damaged parts immediately.
- Do not exceed the maximum working pressure of the lowest rated component in your system. This equipment has a **8.3 bar maximum working pressure at 8.3 bar maximum incoming air pressure**.
- Use fluids and solvents which are compatible with the equipment wetted parts. Refer to the **Technical Data** section of all equipment manuals. Read the fluid and solvent manufacturer's warnings.
- Do not use hoses to pull equipment.
- Route hoses away from traffic areas, sharp edges, moving parts, and hot surfaces. Do not expose VERDER hoses to temperatures above 82°C or below -40°C.
- Do not lift pressurized equipment.
- Wear hearing protection when operating this equipment.
- Comply with all applicable local, state, and national fire, electrical, and safety regulations.

## Warning



### TOXIC FLUID HAZARD

Hazardous fluid or toxic fumes can cause serious injury or death if splashed in the eyes or on the skin, inhaled, or swallowed.



- Know the specific hazards of the fluid you are using.
- Store hazardous fluid in an approved container. Dispose of hazardous fluid according to all local, state, and national guidelines.
- Always wear protective eyewear, gloves, clothing, and respirator as recommended by the fluid and solvent manufacturer.
- Pipe and dispose of the exhaust air safely, away from people, animals, and food handling areas. If the diaphragm fails, the fluid is exhausted along with the air. See **Air Exhaust Ventilation** on page 10.



### FIRE AND EXPLOSION HAZARD

Improper grounding, poor ventilation, open flames or sparks can cause a hazardous condition and result in a fire or explosion and serious injury.



- Ground the equipment. Refer to **Grounding** on page 4.
- **Never** use a non-conductive polypropylene or PVDF pump in an explosive atmosphere or with non-conductive flammable fluids as specified by your local fire protection code. Refer to **Grounding** on page 4 for additional information. Consult your fluid supplier to determine the conductivity or resistivity of your fluid.
- If there is any static sparking or you feel an electric shock while using this equipment, **stop pumping immediately**. Do not use the equipment until you identify and correct the problem.
- Provide fresh air ventilation to avoid the buildup of flammable fumes from solvents or the fluid being sprayed, dispensed, or transferred.
- Pipe and dispose of the exhaust air safely, away from all sources of ignition. If the diaphragm fails, the fluid is exhausted along with the air. See **Air Exhaust Ventilation** on page 10.
- Keep the work area free of debris, including solvent, rags, and gasoline.
- Electrically disconnect all equipment in the work area.
- Extinguish all open flames or pilot lights in the work area.
- Do not smoke in the work area.
- Do not turn on or off any light switch in the work area while operating or if fumes are present.
- Do not operate a gasoline engine in the work area.

## Installation

### General Information

1. The Typical Installation shown in Fig. 2 is only a guide for selecting and installing system components. Contact your VERDER Customer Service for assistance in planning a system to suit your needs.
2. Always use Genuine VERDER Parts and Accessories. Be sure all accessories are adequately sized and pressure-rated to meet the system's requirements.
3. Reference numbers and letters in parentheses refer to the callouts in the figures and the parts lists on pages 26–27.
4. Variations in color between the plastic components of this pump are normal. Color variation does not affect the performance of the pump.

### Warning



#### TOXIC FLUID HAZARD

Hazardous fluid or toxic fumes can cause serious injury or death if splashed in the eyes or on the skin, inhaled, or swallowed.

1. Read **TOXIC FLUID HAZARD** on page 3.
2. Use fluids and solvents which are compatible with the equipment wetted parts. Refer to the **Technical Data** section of all equipment manuals. Read the fluid and solvent manufacturer's warnings.

### Tightening Screws Before First Use

Before using the pump for the first time, check and retorque all external fasteners. See **Torque Sequence**, page 28. After the first day of operation, retorque the fasteners. Although pump use varies, a general guideline is to retorque fasteners every two months.

### Grounding

#### Warning



#### FIRE AND EXPLOSION HAZARD

This pump must be grounded. Before operating the pump, ground the system as explained below. Also, read the section **FIRE AND EXPLOSION HAZARD**, on page 3.



The non-conductive polypropylene and PVDF pumps are **not** conductive. Attaching the ground wire to the grounding strip grounds only the air motor.

When pumping conductive flammable fluids, **always** ground the entire fluid system by making sure the fluid has an electrical path to a true earth ground. See Fig. 1.

**Never** use a non-conductive polypropylene or PVDF pump in an explosive atmosphere or with non-conductive flammable fluids as specified by your local fire protection code.

U.S. Code (NFPA 77 Static Electricity) recommends a conductivity greater than  $50 \times 10^{-12}$  Siemens/meter (mhos/meter) over your operating temperature range to reduce the hazard of fire. Consult your fluid supplier to determine the conductivity or resistivity of your fluid. The resistivity must be less than  $2 \times 10^{12}$  ohm-centimeters.

# Installation

## Grounding (continued)

To reduce the risk of static sparking, ground the pump and all other equipment used or located in the pumping area. Check your local electrical code for detailed grounding instructions for your area and type of equipment.

### Ground all of this equipment:

- *Air Motor:* Connect a ground wire and clamp as shown in Fig. 1. Loosen the grounding screw (W). Insert one end of a 1.5 mm<sup>2</sup> minimum ground wire (Y) behind the grounding screw and tighten the screw securely. Connect the clamp end of the ground wire to a true earth ground. Order Part No. 819.4486 Ground Wire and Clamp.

**NOTE:** When pumping conductive flammable fluids with a non-conductive polypropylene or a PVDF pump, **always** ground the entire fluid system. See the **Warning** on page 4.

- *Air and Fluid hoses:* Use only electrically conductive hoses.
- *Air compressor:* Follow the manufacturer's recommendations.

- *All solvent pails used when flushing,* according to local code. Use only metal pails, which are conductive. Do not place the pail on a non-conductive surface, such as paper or cardboard, which interrupts the grounding continuity.
- *Fluid supply container:* Follow local code.

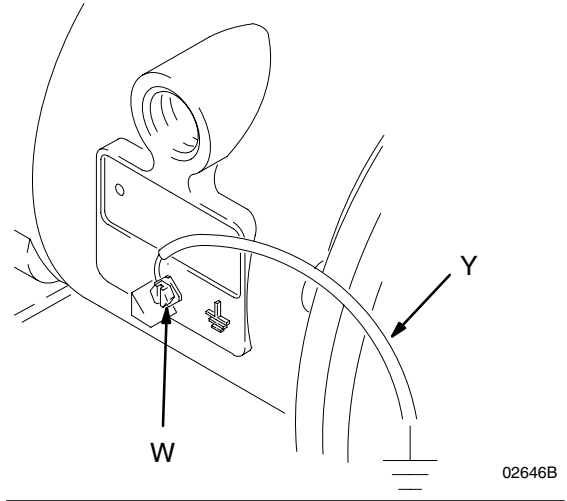

Fig. 1

# Installation

## Air Line

### Warning

A bleed-type master air valve (B) is required in your system to relieve air trapped between this valve and the pump. Trapped air can cause the pump to cycle unexpectedly, which could result in serious injury, including splashing in the eyes or on the skin, injury from moving parts, or contamination from hazardous fluids. See Fig. 2.

1. Install the air line accessories as shown in Fig. 2. Mount these accessories on the wall or on a bracket. Be sure the air line supplying the accessories is electrically conductive.
  - a. Install an air regulator (C) and gauge to control the fluid pressure. The fluid outlet pressure will be the same as the setting of the air regulator.

- b. Locate one bleed-type master air valve (B) close to the pump and use it to relieve trapped air. See the **Warning** at left. Locate the other master air valve (E) upstream from all air line accessories and use it to isolate them during cleaning and repair.

- c. The air line filter (F) removes harmful dirt and moisture from the compressed air supply.

2. Install an electrically conductive, flexible air hose (A) between the accessories and the 1/2 npt(f) pump air inlet (N). See Fig. 2. Use a minimum 13 mm ID air hose.

3. Screw an air line quick disconnect coupler (D) onto the end of the air hose (A); be sure the coupler porting is large enough to not restrict the air flow, which will affect pump performance. Screw the mating fitting into the pump air inlet snugly. Do not connect the coupler (D) to the fitting until you are ready to operate the pump.

## FLOOR MOUNT TYPICAL INSTALLATION

### KEY FOR FIG. 2

- A Electrically Conductive Air Supply Hose
- B Bleed-Type Master Air Valve (required for pump)
- C Air Regulator
- D Air Line Quick Disconnect
- E Master Air Valve (for accessories)
- F Air Line Filter
- G Fluid Suction Hose
- H Fluid Supply
- J Fluid Drain Valve (required)
- K Fluid Shutoff Valve
- L Fluid Hose
- N 1/2 npt(f) Air Inlet Port
- R 2 in. Fluid Inlet Flange
- S 2 in. Fluid Outlet Flange
- Y Ground Wire (required; see page 5 for installation instructions)

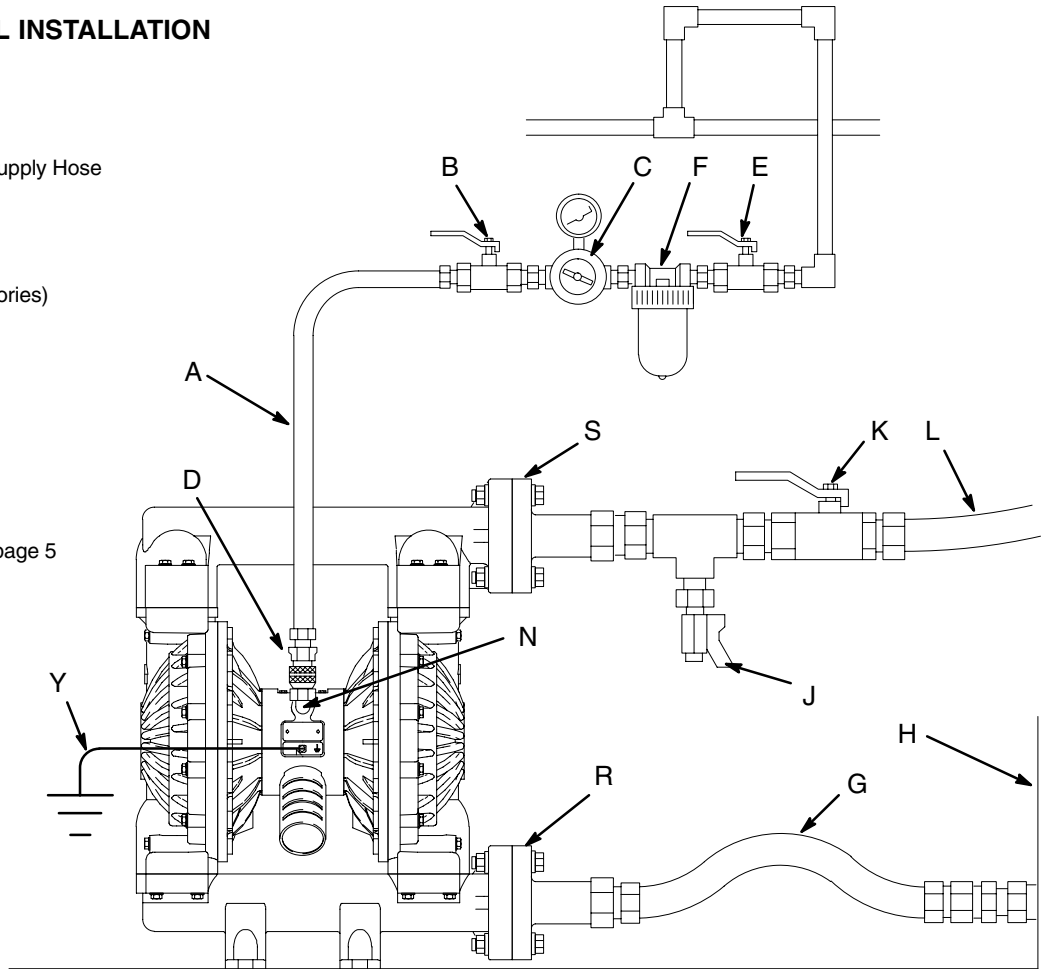

04614B

Fig. 2

# Installation

## Mountings

### Caution

The pump exhaust air may contain contaminants. Ventilate to a remote area if the contaminants could affect your fluid supply. See **Air Exhaust Ventilation** on page 10.

1. Be sure the mounting surface can support the weight of the pump, hoses, and accessories, as well as the stress caused during operation.
2. For all mountings, be sure the pump is bolted directly to the mounting surface.
3. For ease of operation and service, mount the pump so the air valve cover (2), air inlet, and fluid inlet and outlet ports are easily accessible.
4. Rubber Foot Mounting Kit 819.4333 is available to reduce noise and vibration during operation.

## Fluid Suction Line

1. The pump fluid inlet (R) is a 2 in. raised face flange. Refer to **Flange Connections** on page 8.

2. If the fluid inlet pressure to the pump is more than 25% of the outlet working pressure, the ball check valves will not close fast enough, resulting in inefficient pump operation.
3. At inlet fluid pressures greater than 1.05 bar, diaphragm life will be shortened.
4. See the **Technical Data** on page 30 for maximum suction lift (wet and dry).

## Fluid Outlet Line

### Warning

A fluid drain valve (J) is required to relieve pressure in the hose if it is plugged. The drain valve reduces the risk of serious injury, including splashing in the eyes or on the skin, or contamination from hazardous fluids when relieving pressure. Install the valve close to the pump fluid outlet. See Fig. 2.

1. The pump fluid outlet (S) is a 2 in. raised face flange. Refer to **Flange Connections** on page 8.
2. Install a fluid drain valve (J) near the fluid outlet. See the **Warning** above.
3. Install a shutoff valve (K) in the fluid outlet line.

# Installation

## Flange Connections

The fluid inlet and outlet ports are 2 in. raised face, standard 150 lb class pipe flanges. Connect 2 in. flanged plastic pipe to the pump as follows. You will need:

- torque wrench
- adjustable wrench
- a 6 in. diameter, 1/8 in. thick PTFE gasket, with four 0.75 in. diameter holes on a 4.75 in. diameter bolt circle, and a 2.20 in. diameter center
- four 5/8 in. x 3 in. bolts
- four 5/8 in. spring lockwashers
- eight 5/8 in. flat washers
- four 5/8 in. nuts.

1. Place a flat washer (E) on each bolt (C). Refer to Fig. 3.
2. Align the holes in the gasket (B) and the pipe flange (A) with the holes in the pump outlet flange (S).
3. Lubricate the threads of the four bolts. Install the bolts through the holes and secure with the washers (E), lockwashers (D), and nuts (F).
4. Hold the nuts with a wrench. Refer to the tightening sequence in Fig. 3 and torque the bolts to 27–41 N•m. **Do not over-torque.**
5. Repeat for the pump inlet flange (R).

### BOLT TIGHTENING SEQUENCE

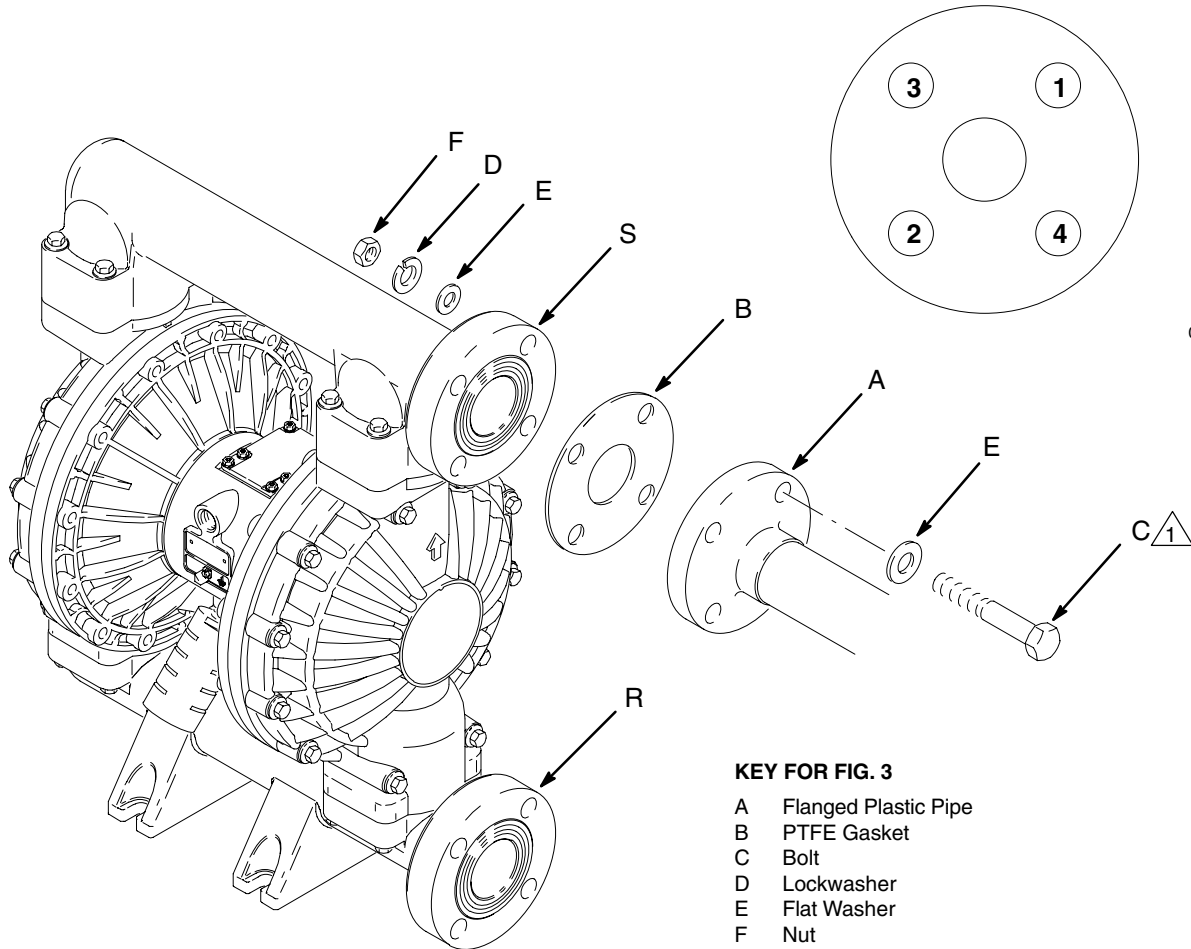

04405

#### KEY FOR FIG. 3

- A Flanged Plastic Pipe
- B PTFE Gasket
- C Bolt
- D Lockwasher
- E Flat Washer
- F Nut
- R 2 in. Fluid Inlet Flange
- S 2 in. Fluid Outlet Flange

 Lubricate threads. Torque to 27–41 N•m. Do not over-torque.

Fig. 3

04615B



# Installation

## Changing the Orientation of the Fluid Inlet and Outlet Ports

The pump is shipped with the fluid inlet (R) and outlet (S) ports facing the same direction. See Fig. 4. To change the orientation of the inlet and/or outlet port:

1. Remove the screws and washers (106, 112, 113, and 114) holding the inlet (102) and/or outlet (103) manifold to the covers (101).
2. Reverse the manifold and reattach. Install the screws and torque to 17–18 N•m. See **Torque Sequence**, page 28.

### KEY

N	1/2 npt(f) Air Inlet Port	106	Fluid Outlet Manifold Screws (Top)
P	Muffler; Air Exhaust Port is 3/4 npt(f)	112	Fluid Inlet Manifold Screws (Bottom)
R	2 in. Fluid Inlet Flange	113	Fluid Outlet Manifold Washers
S	2 in. Fluid Outlet Flange	114	Fluid Inlet Manifold Washers
101	Fluid Covers		
102	Fluid Inlet Manifold		
103	Fluid Outlet Manifold		

1 Torque to 17–18 N•m. See **Torque Sequence**, page 28.

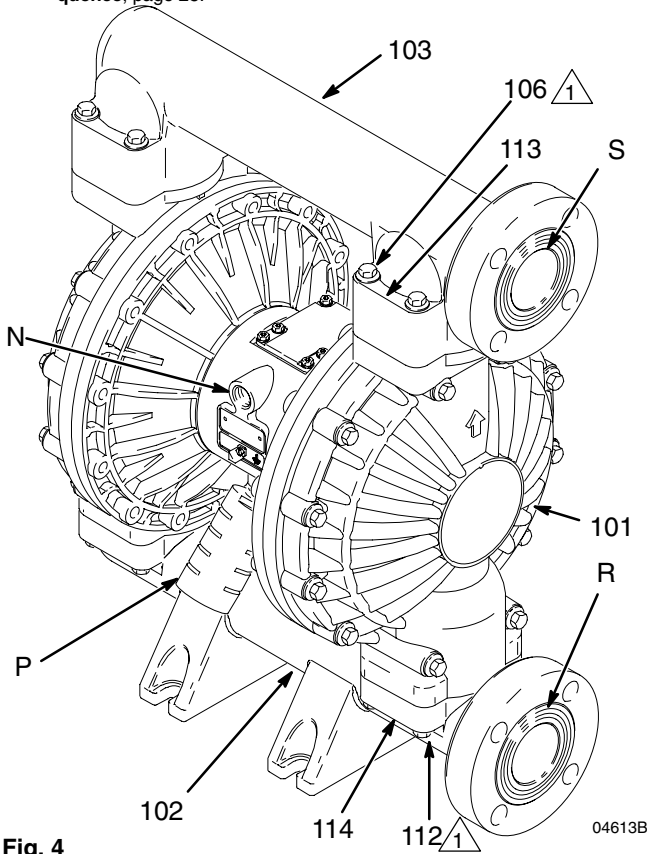

Fig. 4

## Fluid Pressure Relief Valve

### ⚠ Caution

Some systems may require installation of a pressure relief valve at the pump outlet to prevent overpressurization and rupture of the pump or hose. See Fig. 5.

Thermal expansion of fluid in the outlet line can cause overpressurization. This can occur when using long fluid lines exposed to sunlight or ambient heat, or when pumping from a cool to a warm area (for example, from an underground tank).

Overpressurization can also occur if the *VERDERAIR* pump is being used to feed fluid to a piston pump, and the intake valve of the piston pump does not close, causing fluid to back up in the outlet line.

### KEY

R	2 in. Fluid Inlet Flange
S	2 in. Fluid Outlet Flange
V	Pressure Relief Valve Part No. 819.0159 (Stainless Steel)

- 1 Install valve between fluid inlet and outlet ports.
- 2 Connect fluid inlet line here.
- 3 Connect fluid outlet line here.

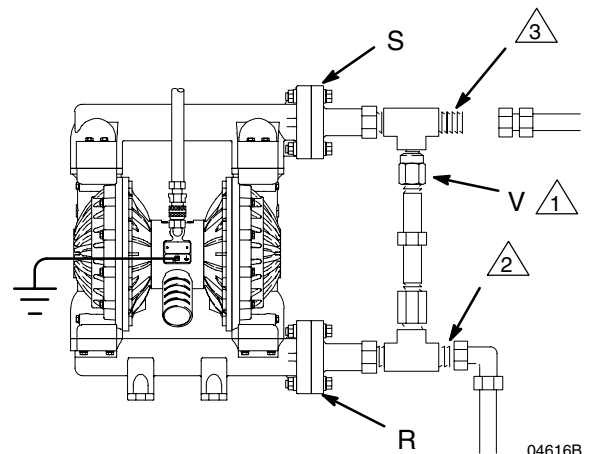

Fig. 5

# Installation

## Air Exhaust Ventilation

### Warning



#### FIRE AND EXPLOSION HAZARD

Be sure to read and follow the warnings and precautions regarding **TOXIC FLUID HAZARD**, and **FIRE OR EXPLOSION HAZARD** on page 3, before operating this pump.



Be sure the system is properly ventilated for your type of installation. You must vent the exhaust to a safe place, away from people,

animals, food handling areas, and all sources of ignition when pumping flammable or hazardous fluids.

Diaphragm failure will cause the fluid being pumped to exhaust with the air. Place an appropriate container at the end of the air exhaust line to catch the fluid. See Fig. 6.

The air exhaust port is 3/4 npt(f). Do not restrict the air exhaust port. Excessive exhaust restriction can cause erratic pump operation.

If the muffler (P) is installed directly to the air exhaust port, apply PTFE thread tape or anti-seize lubricant to the muffler threads before assembly.

To provide a remote exhaust:

1. Remove the muffler (P) from the pump air exhaust port.
2. Install an electrically conductive air exhaust hose (T) and connect the muffler (P) to the other end of the hose. The minimum size for the air exhaust hose is 19 mm ID. If a hose longer than 4.57 m is required, use a larger diameter hose. Avoid sharp bends or kinks in the hose. See Fig. 6.
3. Place a container (U) at the end of the air exhaust line to catch fluid in case a diaphragm ruptures.

## VENTING EXHAUST AIR

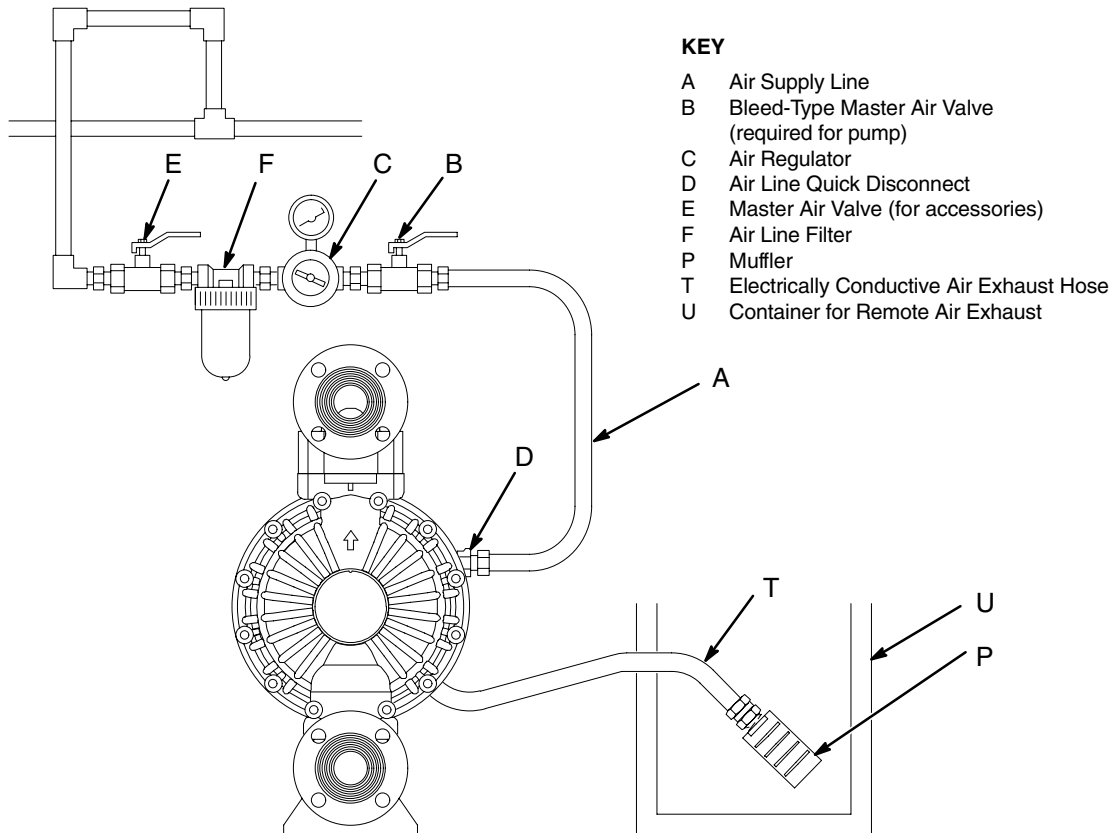

04617

Fig. 6

# Operation

## Pressure Relief Procedure

### Warning

#### PRESSURIZED EQUIPMENT HAZARD

The equipment stays pressurized until pressure is manually relieved. To reduce the risk of serious injury from pressurized fluid, accidental spray from the gun or splashing fluid, follow this procedure whenever you:

- Are instructed to relieve pressure,
  - Stop pumping,
  - Check, clean or service any system equipment,
  - Install or clean fluid nozzles.
1. Shut off the air to the pump.
  2. Open the dispensing valve, if used.
  3. Open the fluid drain valve to relieve all fluid pressure, having a container ready to catch the drainage.

## Flush the Pump Before First Use

The pump was tested with lightweight oil, which is left in the fluid passages to protect parts. To avoid contaminating your fluid with oil, flush the pump with a compatible solvent before using the equipment. Follow the steps under **Starting and Adjusting the Pump**.

## Starting and Adjusting the Pump

### Warning



#### TOXIC FLUID HAZARD

Hazardous fluid or toxic fumes can cause serious injury or death if splashed in the eyes or on the skin, inhaled, or swallowed. Do not lift a pump under pressure. If dropped, the fluid section may rupture. Always follow the **Pressure Relief Procedure** above before lifting the pump.

1. Be sure the pump is properly grounded. Refer to **Grounding** on page 4.
2. Check all fittings to be sure they are tight. Be sure to use a compatible liquid thread sealant on all male threads. Tighten the fluid inlet and outlet fittings securely.
3. Place the suction tube (if used) in the fluid to be pumped.

**NOTE:** If the fluid inlet pressure to the pump is more than 25% of the outlet working pressure, the ball check valves will not close fast enough, resulting in inefficient pump operation.

4. Place the end of the fluid hose (L) into an appropriate container.
5. Close the fluid drain valve (J). See Fig. 2.
6. With the pump air regulator (C) closed, open all bleed-type master air valves (B, E).
7. If the fluid hose has a dispensing device, hold it open while continuing with the following step.
8. Slowly open the air regulator (C) until the pump starts to cycle. Allow the pump to cycle slowly until all air is pushed out of the lines and the pump is primed.

*If you are flushing*, run the pump long enough to thoroughly clean the pump and hoses. Close the air regulator. Remove the suction tube from the solvent and place it in the fluid to be pumped.

## Pump Shutdown

### Warning

To reduce the risk of serious injury whenever you are instructed to relieve pressure, always follow the **Pressure Relief Procedure** at left.

At the end of the work shift, relieve the pressure.

## Maintenance

### Lubrication

The air valve is designed to operate unlubricated. However, if lubrication is desired, every 500 hours of operation (or monthly) remove the hose from the pump air inlet and add two drops of machine oil to the air inlet.

#### **Caution**

Do not over-lubricate the pump. Oil is exhausted through the muffler, which could contaminate your fluid supply or other equipment. Excessive lubrication can also cause the pump to malfunction.

### Flushing and Storage

#### **Warning**

To reduce the risk of serious injury whenever you are instructed to relieve pressure, always follow the **Pressure Relief Procedure** on page 11.

Flush the pump often enough to prevent the fluid you are pumping from drying or freezing in the pump and damaging it. Flush with a fluid that is compatible with the fluid you are pumping and with the wetted parts in your system. Check with your fluid manufacturer or supplier for recommended flushing fluids and flushing frequency.

Always flush the pump and relieve the pressure before storing it for any length of time.

### Tightening Threaded Connections

Before each use, check all hoses for wear or damage, and replace as necessary. Check to be sure all threaded connections are tight and leak-free. Check fasteners. Tighten or retorque as necessary. Although pump use varies, a general guideline is to retorque fasteners every two months. See **Torque Sequence**, page 28.

### Preventive Maintenance Schedule

Establish a preventive maintenance schedule, based on the pump's service history. This is especially important for prevention of spills or leakage due to diaphragm failure.

# Troubleshooting

## Warning

To reduce the risk of serious injury whenever you are instructed to relieve pressure, always follow the **Pressure Relief Procedure** on page 11.

1. Relieve the pressure before checking or servicing the equipment.
2. Check all possible problems and causes before disassembling the pump.

PROBLEM	CAUSE	SOLUTION
Pump cycles at stall or fails to hold pressure at stall.	Worn check valve balls (301), seats (201) or o-rings (202).	Replace. See page 16.
Pump will not cycle, or cycles once and stops.	Air valve is stuck or dirty.	Disassemble and clean air valve. See pages 14–15. Use filtered air.
	Check valve ball (301) severely worn and wedged in seat (201) or manifold (102 or 103).	Replace ball and seat. See page 16.
	Check valve ball (301) is wedged into seat (201), due to overpressurization.	Install Pressure Relief Valve (see page 9).
	Dispensing valve clogged.	Relieve pressure and clear valve.
Pump operates erratically.	Clogged suction line.	Inspect; clear.
	Sticky or leaking balls (301).	Clean or replace. See page 16.
	Diaphragm ruptured.	Replace. See pages 17–19.
	Restricted exhaust.	Remove restriction.
Air bubbles in fluid.	Suction line is loose.	Tighten.
	Diaphragm ruptured.	Replace. See pages 17–19.
	Loose inlet manifold (102), damaged seal between manifold and seat (201), damaged o-rings (202).	Tighten manifold bolts (112) or replace seats (201) or o-rings (202). See page 16.
	Loose fluid side diaphragm plate (105).	Tighten or replace. See pages 17–19.
Fluid in exhaust air.	Diaphragm ruptured.	Replace. See pages 17–19.
	Loose fluid side diaphragm plate (105).	Tighten or replace. See pages 17–19.
Pump exhausts excessive air at stall.	Worn air valve block (7), o-ring (6), plate (8), pilot block (18), u-cups (10), or pilot pin o-rings (17).	Inspect; replace. See pages 14–15.
	Worn shaft seals (402).	Replace. See pages 17–19.
Pump leaks air externally.	Air valve cover (2) or air valve cover screws (3) are loose.	Tighten screws. See page 15.
	Air valve gasket (4) or air cover gasket (22) is damaged.	Inspect; replace. See pages 14–15, 20–21.
	Air cover screws (25) are loose.	Tighten screws. See pages 20–21.
Pump leaks fluid externally from ball check valves.	Loose manifolds (102, 103), damaged seal between manifold and seat (201), damaged o-rings (202).	Tighten manifold bolts (106 and 112) or replace seats (201) or o-rings (202). See page 16.

## Service

### Repairing the Air Valve

#### Tools Required

- Torque wrench
- Torx (T20) screwdriver or 7 mm socket wrench
- Needle-nose pliers
- O-ring pick
- Lithium base grease

**NOTE:** Air Valve Repair Kits 819.4274 (aluminum center housing models) and 819.0249 (stainless steel center housing models) are available. Refer to page 26. Parts included in the kit are marked with a symbol, for example (4†■). Use all the parts in the kit for the best results.

#### Disassembly

### Warning

To reduce the risk of serious injury whenever you are instructed to relieve pressure, always follow the **Pressure Relief Procedure** on page 11.

1. **Relieve the pressure.**
2. With a Torx (T20) screwdriver or 7 mm socket wrench, remove the six screws (3), air valve cover (2), and gasket (4). See Fig. 7.
3. Move the valve carriage (5) to the center position and pull it out of the cavity. Remove the valve block (7) and o-ring (6) from the carriage. Using a needle-nose pliers, pull the pilot block (18) straight up and out of the cavity. See Fig. 8.
4. Pull the two actuator pistons (11) out of the bearings (12). Remove the u-cup packings (10) from the pistons. Pull the pilot pins (16) out of the bearings (15). Remove the o-rings (17) from the pilot pins. See Fig. 9.
5. Inspect the valve plate (8) in place. If damaged, use a Torx (T20) screwdriver or 7 mm socket wrench to remove the three screws (3). Remove the valve plate (8) and, on aluminum center housing models, remove the seal (9). See Fig. 10.
6. Inspect the bearings (12, 15) in place. See Fig. 9. The bearings are tapered and, if damaged, must be removed from the outside. This requires disassembly of the fluid section. See page 20.
7. Clean all parts and inspect for wear or damage. Replace as needed. Reassemble as explained on page 15.

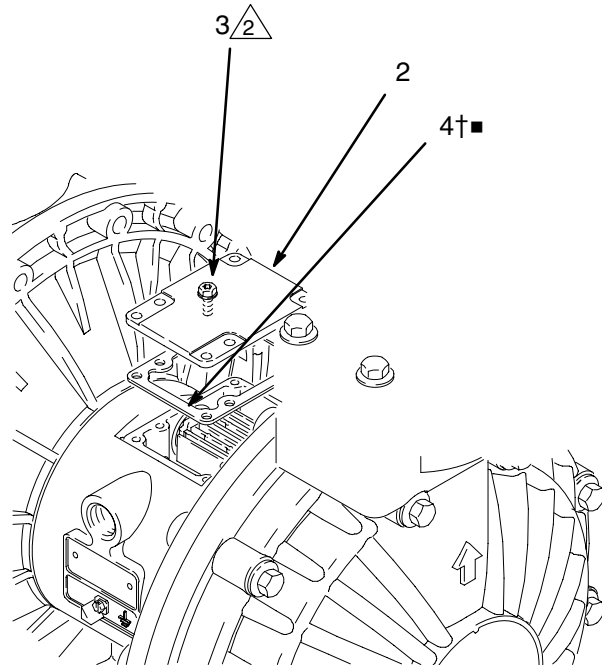

2 Torque to 5.6–6.8 N•m.

04618B

Fig. 7

- 1 See Detail at right.
- 2 Grease.
- 3 Grease lower face.

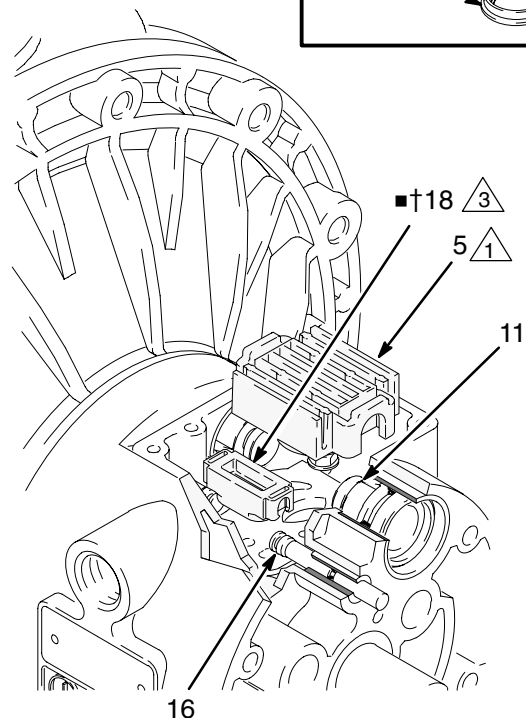
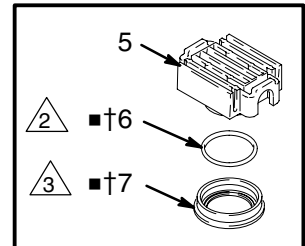

Fig. 8

04900B

# Service

- 1 Insert narrow end first.
- 2 Grease.
- 3 Install with lips facing narrow end of piston (11).
- 4 Insert wide end first.

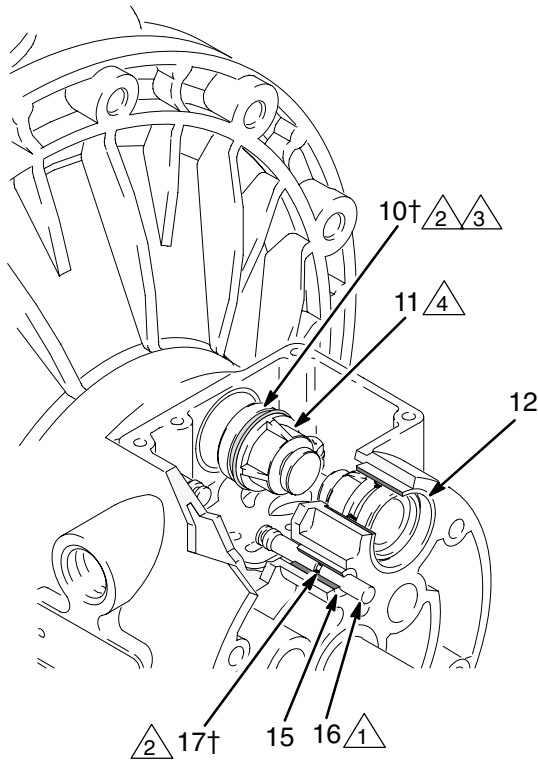

Fig. 9

04901B

- 1 Rounded side must face down.
- 2 Tighten screws until they bottom out on the housing.

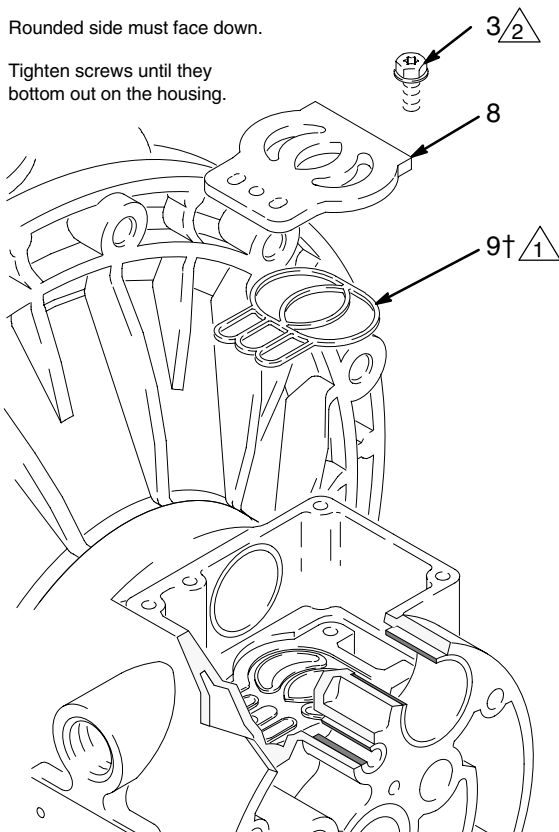

Fig. 10

03947

## Reassembly

1. If you removed the bearings (12, 15), install new ones as explained on page 20. Reassemble the fluid section.
2. On aluminum center housing models, install the valve plate seal (9) into the groove at the bottom of the valve cavity. The rounded side of the seal **must face down** into the groove. See Fig. 10.
3. Install the valve plate (8) in the cavity. On aluminum center housing models, the plate is reversible, so either side can face up. Install the three screws (3), using a Torx (T20) screwdriver or 7 mm socket wrench. Tighten until the screws bottom out on the housing. See Fig. 10.
4. Install an o-ring (17) on each pilot pin (16). Grease the pins and o-rings. Insert the pins into the bearings (15), **narrow** end first. See Fig. 9.
5. Install a u-cup packing (10) on each actuator piston (11), so the lips of the packings face the **narrow** end of the pistons. See Fig. 9.
6. Lubricate the u-cup packings (10) and actuator pistons (11). Insert the actuator pistons in the bearings (12), **wide** end first. Leave the narrow end of the pistons exposed. See Fig. 9.
7. Grease the lower face of the pilot block (18) and install so its tabs snap into the grooves on the ends of the pilot pins (16). See Fig. 8.
8. Grease the o-ring (6) and install it in the valve block (7). Push the block onto the valve carriage (5). Grease the lower face of the valve block. See Fig. 8.
9. Install the valve carriage (5) so its tabs slip into the grooves on the narrow end of the actuator pistons (11). See Fig. 8.
10. Align the valve gasket (4) and cover (2) with the six holes in the center housing (1). Secure with six screws (3), using a Torx (T20) screwdriver or 7 mm socket wrench. Torque to 5.6–6.8 N•m. See Fig. 7.

## Service

### Ball Check Valve Repair

#### Tools Required

- Torque wrench
- 10 mm socket wrench
- O-ring pick

#### Disassembly

**NOTE:** A Fluid Section Repair Kit is available. Refer to page 23 to order the correct kit for your pump. Parts included in the kit are marked with an asterisk, for example (201\*). Use all the parts in the kit for the best results.

**NOTE:** To ensure proper seating of the balls (301), always replace the seats (201) when replacing the balls.

### Warning

To reduce the risk of serious injury whenever you are instructed to relieve pressure, always follow the **Pressure Relief Procedure** on page 11.

1. **Relieve the pressure.** Disconnect all hoses.
2. Remove the pump from its mounting.
3. Using a 10 mm socket wrench, remove the eight bolts (106) and four washers (113), holding the outlet manifold (103) to the fluid covers (101). See Fig. 11.
4. Remove the seats (201), balls (301), and o-rings (202) from the manifold.

**NOTE:** Some models do not use o-rings (202).

5. Turn the pump over and remove the bolts (112), washers (114), and inlet manifold (102). Remove the seats (201), balls (301), and o-rings (202) from the fluid covers (101).

#### Reassembly

1. Clean all parts and inspect for wear or damage. Replace parts as needed.
2. Reassemble in the reverse order, following all notes in Fig. 11. Be sure the ball checks are assembled **exactly** as shown. The arrows (A) on the fluid covers (101) **must** point toward the outlet manifold (103).

 1 Torque to 17–18 N•m. See **Torque Sequence**, page 28.

 2 Arrow (A) must point toward outlet manifold (103).

 3 Not used on some models.

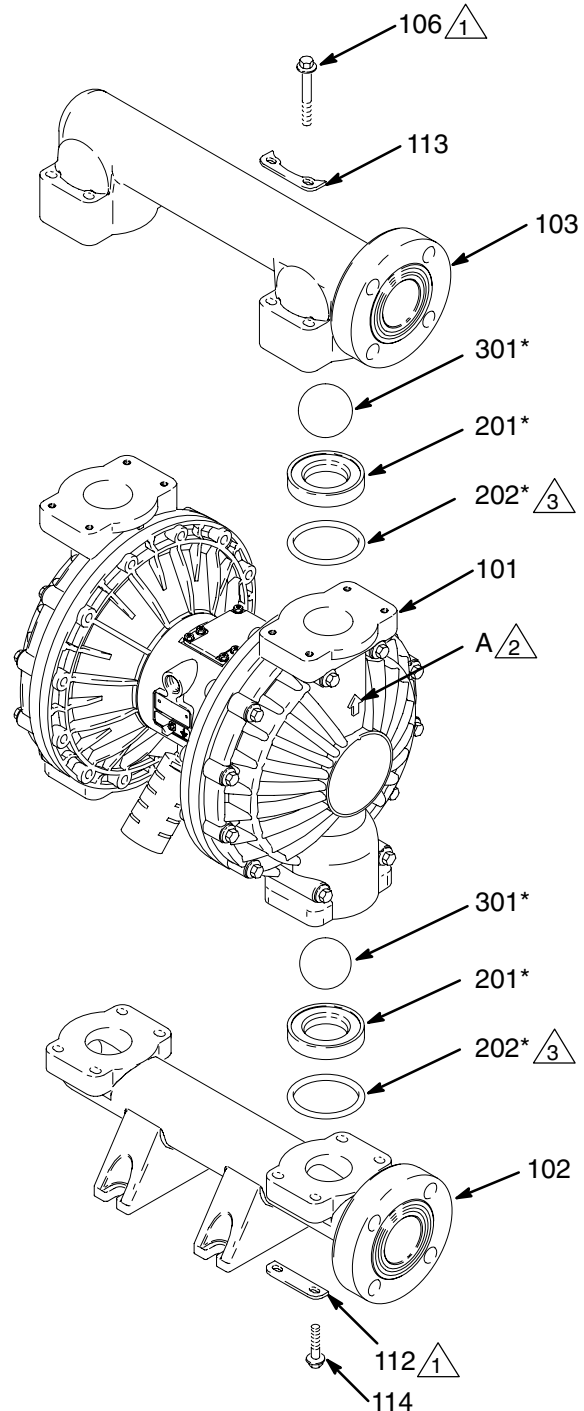

Fig. 11

04619C



# Service

## Diaphragm Repair

### Tools Required

- Torque wrench
- 13 mm socket wrench
- Adjustable wrench
- 19 mm open-end wrench
- O-ring pick
- Lithium-base grease

### Disassembly

**NOTE:** A Fluid Section Repair Kit is available. Refer to page 23 to order the correct kit for your pump. Parts included in the kit are marked with an asterisk, for example (401\*). Use all the parts in the kit for the best results.

**Warning**

To reduce the risk of serious injury whenever you are instructed to relieve pressure, always follow the **Pressure Relief Procedure** on page 11.

1. **Relieve the pressure.**
2. Remove the manifolds and disassemble the ball check valves as explained on page 16.
3. Using 13 mm socket wrenches, remove the screws (107 and 108) holding the fluid covers (101) to the air covers (23). Pull the fluid covers (101) off the pump. See Fig. 12.

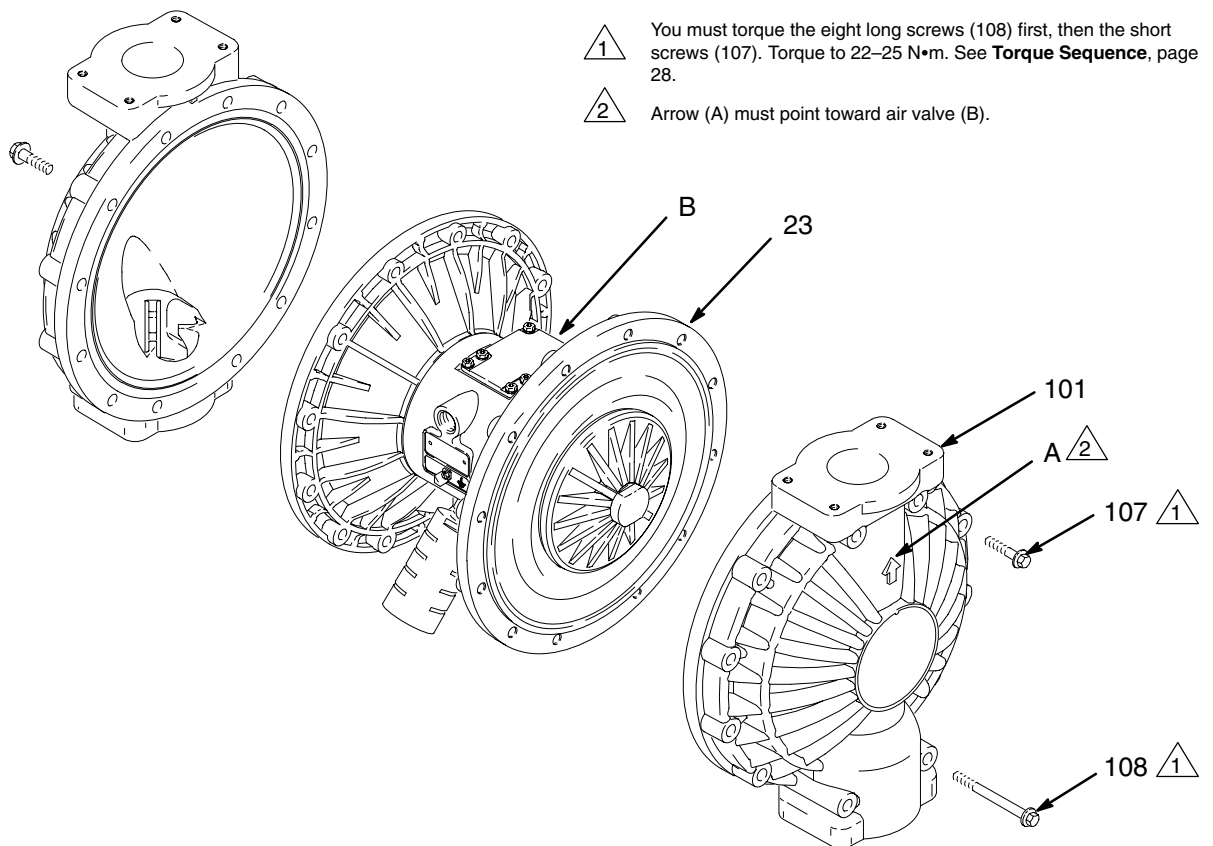

**1** You must torque the eight long screws (108) first, then the short screws (107). Torque to 22–25 N•m. See **Torque Sequence**, page 28.

**2** Arrow (A) must point toward air valve (B).

Fig. 12

04620B

## Service

4. Unscrew one outer plate (105) from the diaphragm shaft (24). Remove one diaphragm (401), and the inner plate (104). See Fig. 13.

**NOTE:** PTFE models include a PTFE diaphragm (403) in addition to the backup diaphragm (401).

5. Pull the other diaphragm assembly and the diaphragm shaft (24) out of the center housing (1). Hold the shaft flats with a 19 mm open-end wrench, and remove the outer plate (105) from the shaft. Disassemble the remaining diaphragm assembly.
6. Inspect the diaphragm shaft (24) for wear or scratches. If it is damaged, inspect the bearings (19) in place. If the bearings are damaged, refer to page 20.
7. Reach into the center housing (1) with an o-ring pick and hook the u-cup packings (402), then pull them out of the housing. This can be done with the bearings (19) in place.
8. Clean all parts and inspect for wear or damage. Replace parts as needed.

## Reassembly

1. Grease the shaft u-cup packings (402\*) and install them so the lips face **out** of the housing (1). See Fig. 13.
2. Grease the length and ends of the diaphragm shaft (24) and slide it through the housing (1).
3. Assemble the inner diaphragm plates (104), diaphragms (401\*), PTFE diaphragms (403\*, if present), and outer diaphragm plates (105) *exactly* as shown in Fig. 13. These parts **must** be assembled correctly.
4. Apply medium-strength (blue) Loctite® or equivalent to the threads of the fluid-side plates (105). Hold one of the outer plates (105) with a wrench and torque the other outer plate to 27 to 34 N•m at 100 rpm maximum. Do not over-torque.
5. Align the fluid covers (101) and the center housing (1) so the arrows (A) on the covers face the same direction as the air valve (B). Secure the covers with the screws (107 and 108), handtight. Install the longer screws (108) in the top and bottom holes of the covers. See Fig. 12.
6. First, torque the longer screws (108) oppositely and evenly to 22–25 N•m, using a 13 mm socket wrench. Then torque the shorter screws (107). See **Torque Sequence**, page 28.
7. Reassemble the ball check valves and manifolds as explained on page 16.

# Service

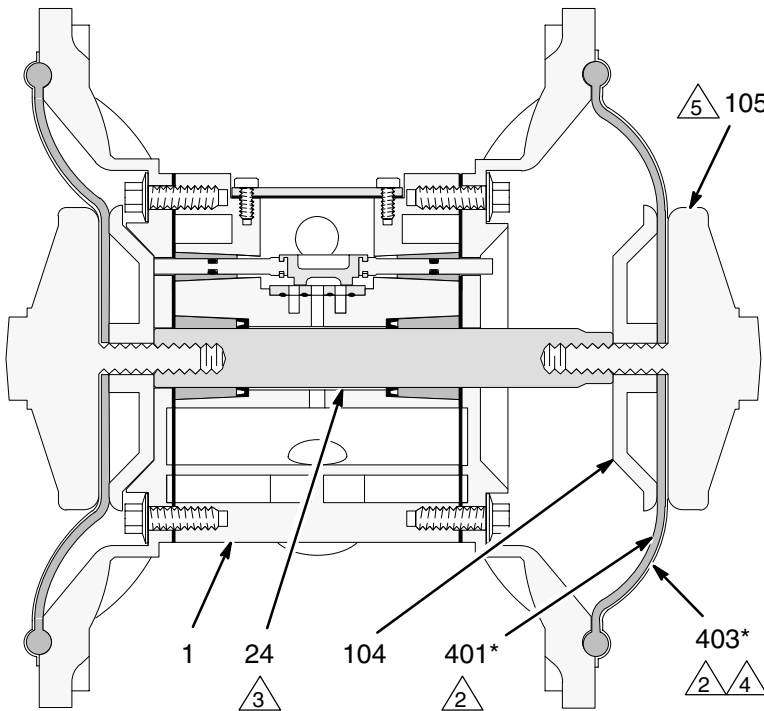

04708

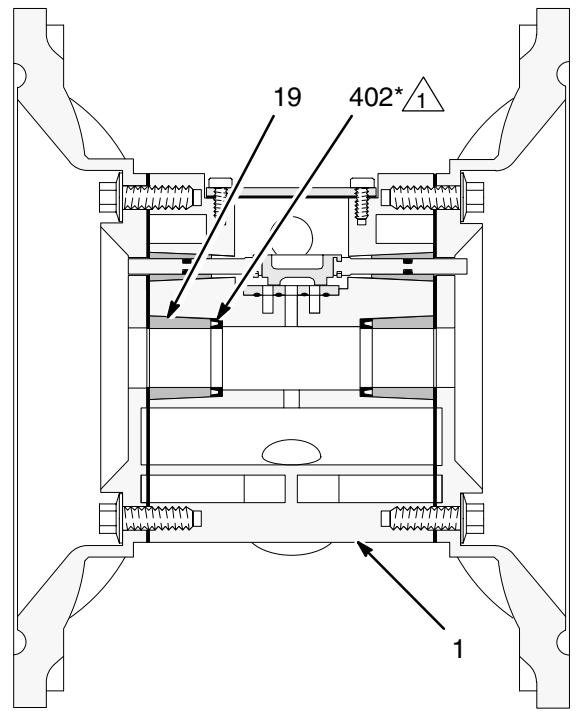

03982

**Cutaway View, with Diaphragms in Place**

**Cutaway View, with Diaphragms Removed**

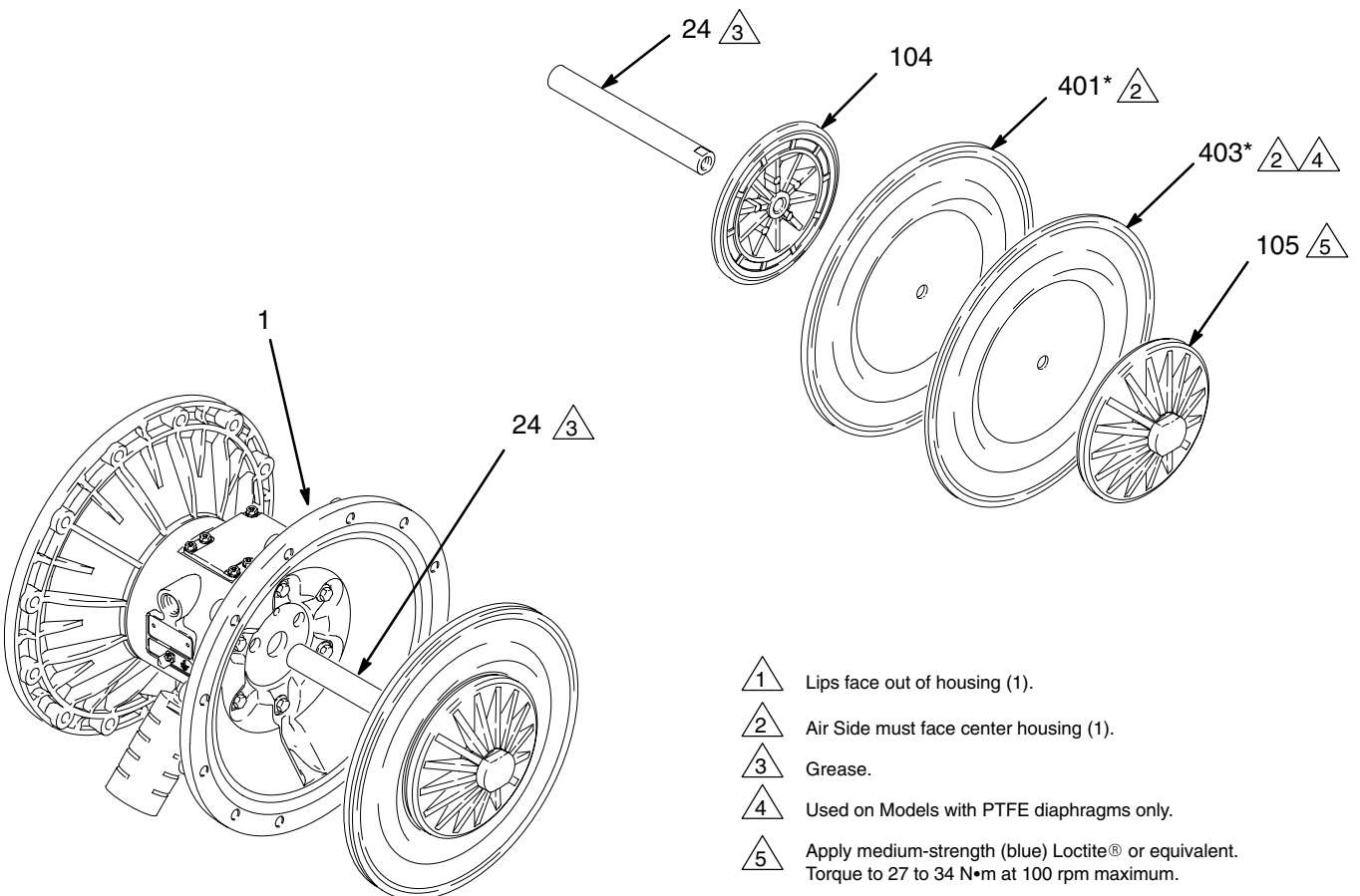

- △1 Lips face out of housing (1).
- △2 Air Side must face center housing (1).
- △3 Grease.
- △4 Used on Models with PTFE diaphragms only.
- △5 Apply medium-strength (blue) Loctite® or equivalent. Torque to 27 to 34 N•m at 100 rpm maximum.

**Fig. 13**

04621B

## Service

### Bearing and Air Gasket Removal

#### Tools Required

- Torque wrench
- 10 mm socket wrench
- Bearing puller
- O-ring pick
- Press, or block and mallet

#### Disassembly

**NOTE:** Do not remove undamaged bearings.

### Warning

To reduce the risk of serious injury whenever you are instructed to relieve pressure, always follow the **Pressure Relief Procedure** on page 11.

1. **Relieve the pressure.**
2. Remove the manifolds and disassemble the ball check valves as explained on page 16.
3. Remove the fluid covers and diaphragm assemblies as explained on page 17.

**NOTE:** If you are removing only the diaphragm shaft bearing (19), skip step 4.

4. Disassemble the air valve as explained on page 14.
5. Using a 10 mm socket wrench, remove the screws (25) holding the air covers (23) to the center housing (1). See Fig. 14.

6. Remove the air cover gaskets (22). Always replace the gaskets with new ones.
7. Use a bearing puller to remove the diaphragm shaft bearings (19), air valve bearings (12) or pilot pin bearings (15). Do not remove undamaged bearings.
8. If you removed the diaphragm shaft bearings (19), reach into the center housing (1) with an o-ring pick and hook the u-cup packings (402), then pull them out of the housing. Inspect the packings. See Fig. 13.

#### Reassembly

1. If removed, install the shaft u-cup packings (402\*) so the lips face **out** of the housing (1).
2. The bearings (19, 12, and 15) are tapered and can only be installed one way. Insert the bearings into the center housing (1), **tapered end first**. Using a press or a block and rubber mallet, press-fit the bearing so it is flush with the surface of the center housing.
3. Reassemble the air valve as explained on page 15.
4. Align the new air cover gasket (22) so the pilot pin (16) protruding from the center housing (1) fits through the proper hole (H) in the gasket.
5. Align the air cover (23) so the pilot pin (16) fits in the middle hole (M) of the three small holes near the center of the cover. Install the screws (25), handtight. See Fig. 14. Using a 10 mm socket wrench, torque the screws oppositely and evenly to 15–17 N•m.
6. Install the diaphragm assemblies and fluid covers as explained on page 17.
7. Reassemble the ball check valves and manifolds as explained on page 16.

# Service

- 1 Insert bearings tapered end first.
- 2 Press-fit bearings flush with surface of center housing (1).
- 3 Torque to 15–17 N•m.

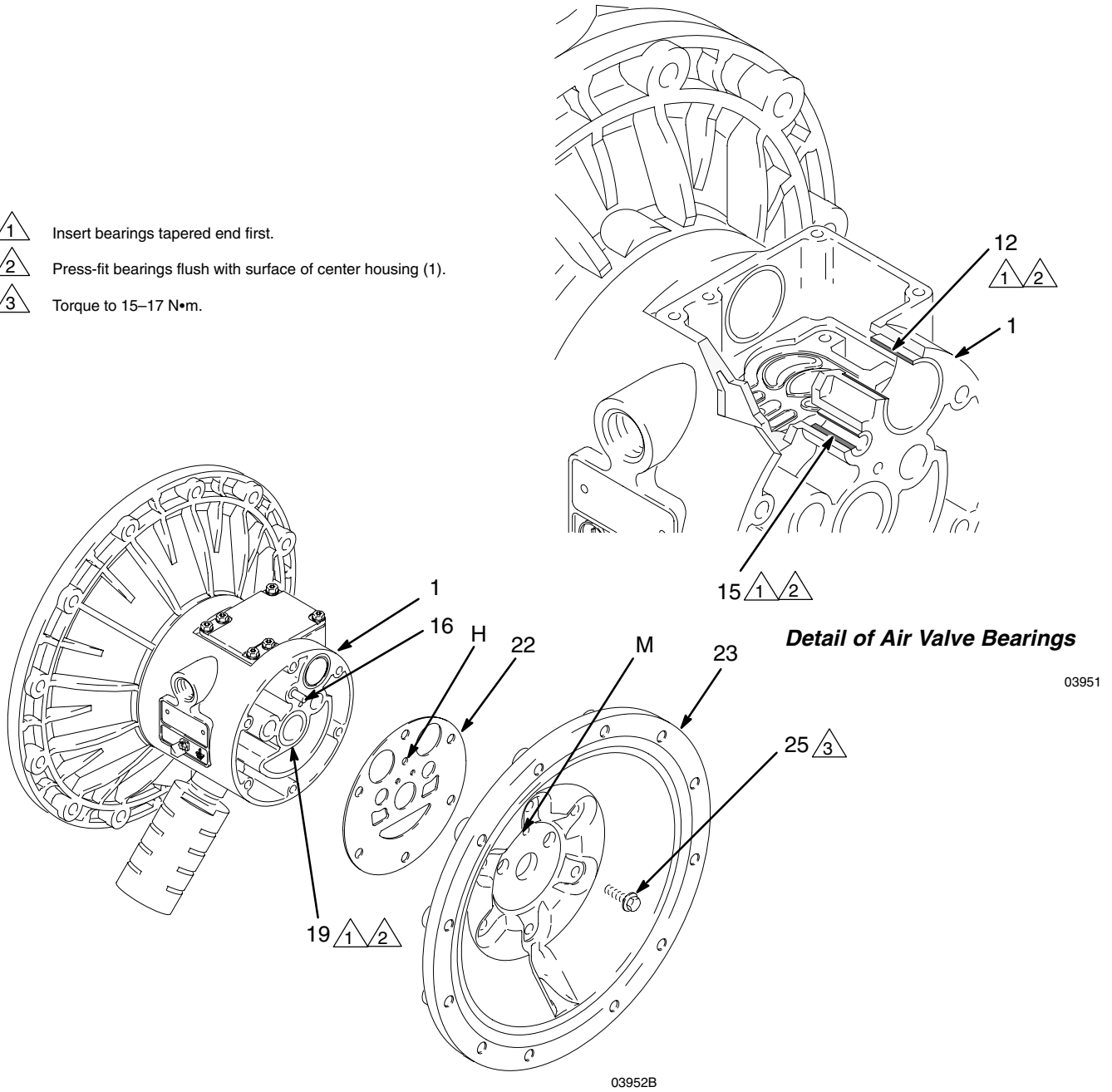

Fig. 14

# Pump Listing

## **VERDERAIR VA 50 Polypropylene and PVDF Pumps, Series B**

Your Model No. is marked on the pump's serial plate. The listing of existing *VERDERAIR VA 50* pumps is below:

<b>Part No.</b>	<b>Air Section</b>	<b>Fluid Section</b>	<b>Seats</b>	<b>Balls</b>	<b>Dia-phragms</b>
810.4129	ALU	KYN	316	TEF	TEF
810.4249	ALU	KYN	KYN	TEF	TEF
810.4272	ALU	KYN	KYN	VIT	VIT
810.4027	ALU	POL	SAN	SAN	SAN
810.4033	ALU	POL	POL	TEF	TEF
810.4046	ALU	POL	POL	HYT	HYT
810.4051	ALU	POL	POL	SAN	SAN
810.4056	ALU	POL	POL	VIT	VIT
810.6989	ALU	POL	POL	GEO	GEO
810.7036	ALU	KYN	KYN	TEF	TEF
810.0105	ALU	POL	SST	BUN	BUN
810.0106	ALU	POL	BUN	BUN	BUN
810.0107	ALU	POL	VIT	VIT	VIT
810.0114	ALU	KYN	VIT	VIT	VIT
810.0115	SST	POL	SST	BUN	BUN
810.0116	SST	POL	SST	TEF	TEF
810.0117	SST	POL	VIT	VIT	VIT
810.0120	SST	KYN	SST	TEF	TEF
810.0448	ALU	CPP	316	BUN	BUN
810.0449	ALU	CPP	316	VIT	VIT
810.0450	ALU	CPP	HYT	HYT	HYT
810.0451	ALU	CPP	SAN	SAN	SAN
810.0452	ALU	CPP	BUN	BUN	BUN
810.0453	ALU	CPP	VIT	VIT	VIT
810.0454	ALU	CPP	POL	TEF	TEF
810.0455	ALU	CPP	POL	HYT	HYT
810.0456	ALU	CPP	POL	SAN	SAN
810.0457	ALU	CPP	POL	VIT	TEF
810.0458	ALU	CPP	POL	VIT	VIT
810.0459	ALU	CPP	POL	GEO	GEO
810.0460	ALU (Remote)	CPP	POL	SAN	SAN
810.0461	SST	CPP	316	TEF	TEF
810.0462	SST	CPP	316	BUN	BUN
810.0463	SST	CPP	VIT	VIT	VIT
810.0464	SST	CPP	POL	TEF	TEF

ACE = Acetal HYT = TPE POL = Polypropylene TEF = PTFE ALU= Aluminium SAN = Santoprene VIT = Fluoroelastomer  
440 = 440C sst SST = Stainless Steel KYN = PVDF 316 = 316 SST GEO=Geolast CPP=Conductive Polypropylene

### **819.7139 Stainless Steel Air Motor Conversion Kit**

Use kit 819.7139 and refer to instruction manual 819.7140 (included with kit) to convert from aluminum air motor to stainless steel air motor.

# Repair Kit Listing

## For **VERDERAIR VA 50** Polypropylene and PVDF Pumps, Series B

Repair Kits may only be ordered as kits. To repair the air valve, order **Part No. 819.4274** for aluminum center housing models and **Part No. 819.0249** for stainless steel center housing models (see page 26). Parts included in the Air Valve Repair Kit are marked with a symbol in the parts list, for example (4†■). The list of existing Repair Kits is below:

Part No.	O-Rings	Seats	Balls	Dia-phragms
819.4510	PLA	NUL	NUL	HYT
819.4512	PLA	NUL	NUL	VIT
819.4625	PLA	HYT	ACE	HYT
819.4635	PLA	HYT	HYT	HYT
819.4673	PLA	SAN	SAN	NUL
819.4676	PLA	SAN	SAN	SAN
819.4688	PLA	POL	TEF	NUL
819.4689	PLA	POL	TEF	TEF
819.4703	PLA	POL	HYT	NUL
819.4705	PLA	POL	HYT	HYT
819.4706	PLA	POL	HYT	SAN
819.4708	PLA	POL	SAN	NUL
819.4713	PLA	POL	VIT	NUL
819.4717	PLA	POL	VIT	VIT
819.4723	PLA	KYN	TEF	NUL
819.4549	PLA	316	TEF	TEF
819.4724	PLA	KYN	TEF	TEF
819.4752	PLA	KYN	VIT	VIT
819.4509	PLA	NUL	NUL	TEF
819.4511	PLA	NUL	NUL	SAN
819.4559	PLA	316	440	TEF
819.4711	PLA	POL	SAN	SAN
819.0257	EPDM	NUL	NUL	NUL

ACE = Acetal    HYT = TPE    POL = Polypropylene    TEF = PTFE    SAN = Santoprene    VIT = Fluoroelastomer    NUL = Null  
 PLA = Plastic    316 = 316 SST    KYN = PVDF    440 = 440C sst    EPDM = Ethylene propylene diene monomer

# Parts

## Air Motor Parts List

Ref. No.	Part No.	Description	Qty
1	819.4275	HOUSING, center; alum.	1
	819.7102	HOUSING, center; stainless steel	1
2	819.4276	COVER, air valve; alum.	1
	819.7103	COVER, air valve; stainless steel	1
3	819.0221	SCREW, mach, hex flange hd; M5 x 0.8; 12 mm	9
4†■	819.4278	GASKET, cover; Santoprene®	1
5	819.4279	CARRIAGE; aluminum	1
6†■	819.4280	O-RING; nitrile	1
7†■	819.4281	BLOCK, air valve; acetal	1
8■	819.4282	PLATE, air valve; sst	1
9†	819.4283	SEAL, valve plate; buna-N	1
10†■	819.4284	PACKING, u-cup; nitrile	2
11	819.4285	PISTON, actuator; acetal	2
12	819.4286	BEARING, piston; acetal	2
15	819.4287	BEARING, pin; acetal	2
16	819.4288	PIN, pilot; stainless steel	2
17†■	819.4289	O-RING; buna-N	2
18†■	819.4290	BLOCK, pilot; acetal	1
19	819.4291	BEARING, shaft; acetal	2
20	819.0220	SCREW, grounding	1
22	819.4294	GASKET, air cover; foam	2
23	819.4295	COVER, air; aluminum	2
	819.7110	COVER, air; stainless steel	2
24	819.4296	SHAFT, diaphragm; sst	1
25	819.7051	SCREW; M8 x 1.25; 25 mm	12

## Fluid Section Parts List

Fluid Section Material	Ref. No.	Part No.	Description	Qty
P O L Y P R O P Y L E N E	101	819.4497	COVER, fluid; polypropylene	2
		819.0279	COVER, fluid; conductive polypropylene	2
	102	819.4498	MANIFOLD, inlet; polypropylene	1
		819.0278	MANIFOLD, inlet; conductive polypropylene	1
	103	819.4499	MANIFOLD, outlet; polypropylene	1
		819.0288	MANIFOLD, outlet; conductive polypropylene	1
	104	819.4301	PLATE, air side; aluminum	2
	105	819.4500	PLATE, fluid side; polypropylene	2
	106	819.4375	SCREW; M8 x 1.25; 70 mm; sst	8
	107	819.4491	SCREW; M10 x 1.50; 60 mm; sst	16
	108	819.9753	SCREW; M10 x 1.50; 110 mm; sst	8
	110▲	819.6314	LABEL, warning	1
	111	819.7000	MUFFLER	1
	112	819.4377	SCREW; M8 x 1.25; 40 mm; sst	8
113	819.9758	WASHER; manifold; outlet	4	
114	819.9759	WASHER; manifold; inlet	4	



**Fluid Section Parts List (continued)**

P O L Y - V I N Y L I D E N E  F L U O R I D E  P V D F	101	819.4501	COVER, fluid; PVDF	2
	102	819.4502	MANIFOLD, inlet; PVDF	1
	103	819.4503	MANIFOLD, outlet; PVDF	1
	104	819.4301	PLATE, air side; aluminum	2
	105	819.4504	PLATE, fluid side; PVDF	2
	106	819.4375	SCREW; M8 x 1.25; 70 mm; sst	8
	107	819.4491	SCREW; M10 x 1.50; 60 mm; sst	16
	108	819.9753	SCREW; M10 x 1.50; 110 mm; sst	8
	110▲	819.6314	LABEL, warning	1
	111	819.7000	MUFFLER	1
	112	819.4377	SCREW; M8 x 1.25; 40 mm; sst	8
	113	819.9758	WASHER; manifold; outlet	4
	114	819.9759	WASHER; manifold; inlet	4

## Parts

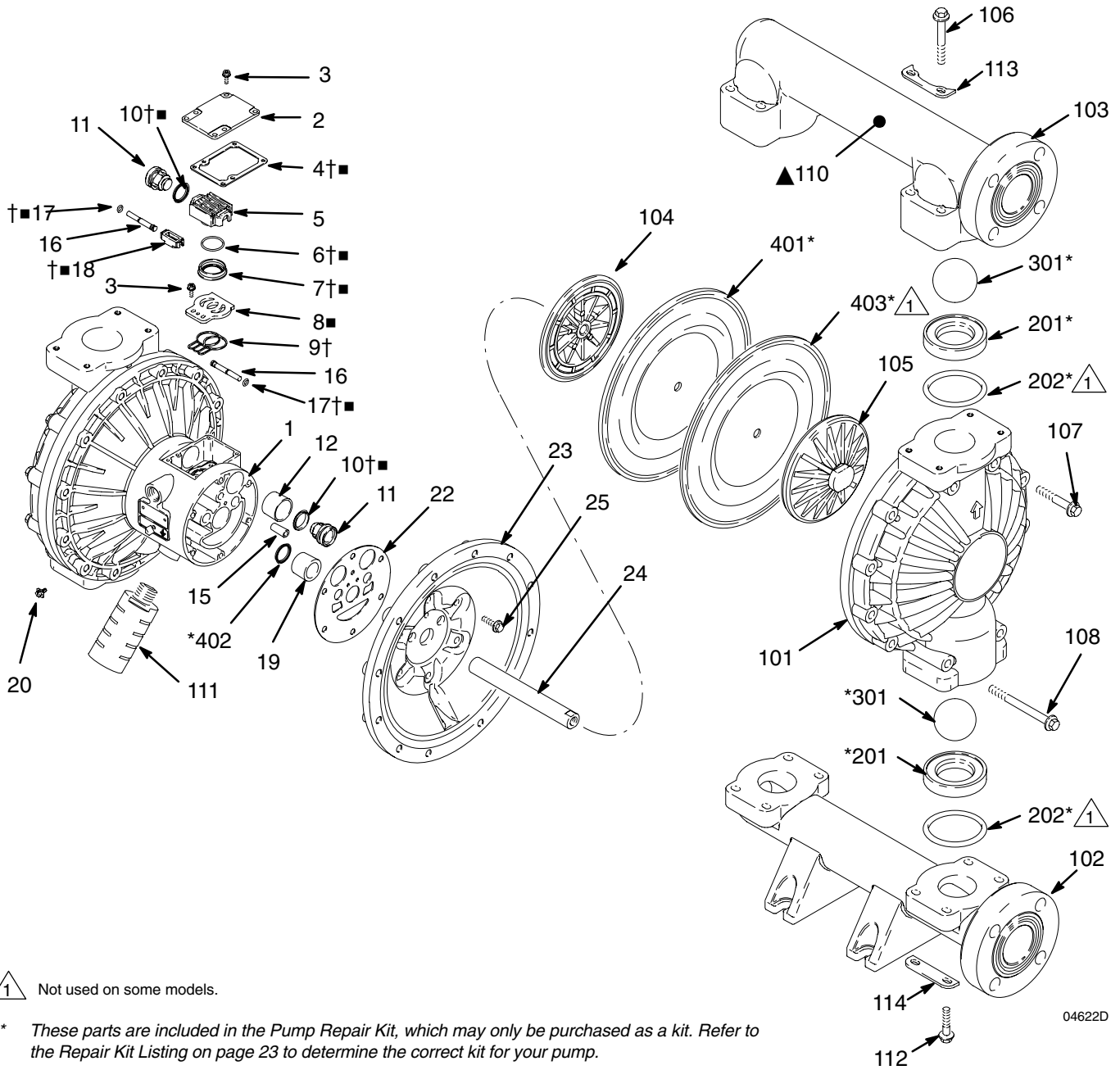

▲ Not used on some models.

\* These parts are included in the Pump Repair Kit, which may only be purchased as a kit. Refer to the Repair Kit Listing on page 23 to determine the correct kit for your pump.

† These parts are included in Air Valve Repair Kit 819.4274 (aluminum center housing models), which may only be purchased as a kit.

■ These parts are included in Air Valve Repair Kit 819.0249 (stainless steel center housing models), which may only be purchased as a kit.

▲ Replacement Danger and Warning labels, tags and cards are available at no cost.

04622D

# Parts

## Seat Parts List

Seat Material	Ref. No.	Part No.	Description	Qty
3 1 6  S S T	201*	819.4315	SEAT; 316 stainless steel	4
	202*	819.4316	O-RING; PTFE	4
1 7 - 4  P H  S S T	201*	819.4317	SEAT; 17-4 stainless steel	4
	202*	819.4316	O-RING; PTFE	4
T P E	201*	819.4318	SEAT; TPE	4
	202	None	Not Used	0
S A N T O P R E N E	201*	819.4319	SEAT; Santoprene	4
	202*	819.4316	O-RING; PTFE	4
B U N A - N	201*	819.7117	SEAT; Buna-N	4
	202*	NONE	NOT USED	0
F L U O R O E L A S T O M E R	201*	819.7115	SEAT; Fluoroelastomer	4
	202	None	Not Used	0
P O L Y P R O P Y L E N E	201*	819.4321	SEAT; Polypropylene	4
	202*	819.4316	O-RING; PTFE	4
P V D F	201*	819.4505	SEAT; PVDF	4
	202*	819.4316	O-RING; PTFE	4

## Ball Parts List

Ref. No.	Part No.	Description	Qty
301*	819.4322	BALL; PTFE	4
301*	819.4323	BALL; acetal	4
301*	819.4324	BALL; 440C stainless steel	4
301*	819.4325	BALL; TPE	4
301*	819.4326	BALL; Santoprene	4
301*	819.7129	BALL; Buna-N	4
301*	819.7128	BALL; Fluoroelastomer	4

## Diaphragm Parts List

Diaphragm Material	Ref. No.	Part No.	Description	Qty
P T F E	401*	not sold separately	DIAPHRAGM, backup; polychloroprene (CR)	2
	402*	819.4284	PACKING, u-cup; nitrile	2
	403*	819.0271	DIAPHRAGM; PTFE	2
T P E	401*	819.4330	DIAPHRAGM; TPE	2
	402*	819.4284	PACKING, u-cup; nitrile	2
S A N T O P R E N E	401*	819.4328	DIAPHRAGM; Santoprene	2
	402*	819.4284	PACKING, u-cup; nitrile	2
B U N A - N	401*	819.7120	DIAPHRAGM; Buna-N	2
	402*	819.4284	PACKING, u-cup; Buna-N	2
F L U O R O E L A S T O M E R	401*	819.7133	DIAPHRAGM; Fluoroelastomer	2
	402*	819.4284	PACKING, u-cup; nitrile	2

\* These parts are included in the pump repair kit, purchased separately. See Repair Kit Listing on page 23 to determine the correct kit for your pump.

## Torque Sequence

Always follow torque sequence when instructed to torque fasteners.

1. Left/Right Fluid Covers  
Torque bolts to 22–25 N•m.

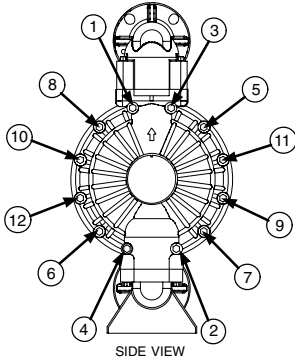

3. Outlet Manifold  
Torque bolts to 17–18 N•m

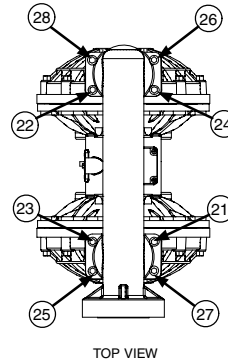

2. Inlet Manifold  
Torque bolts to 17–18 N•m

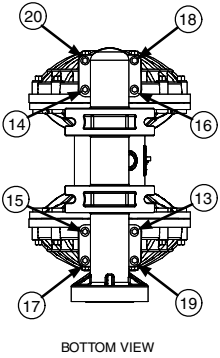

# Dimensions

**FRONT VIEW**

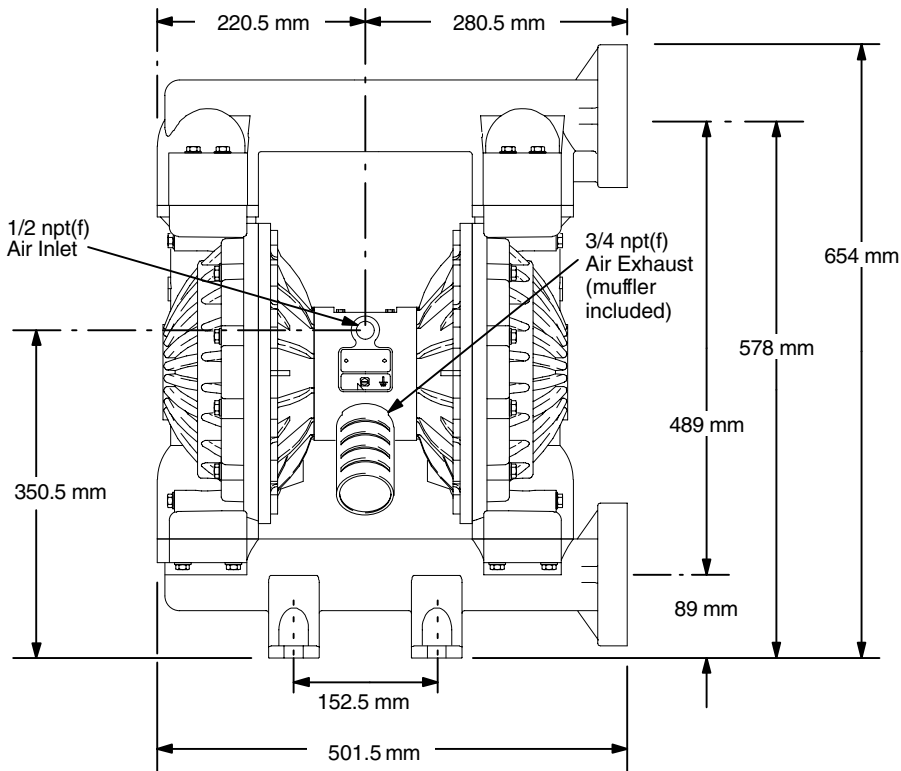

7441B

**SIDE VIEW**

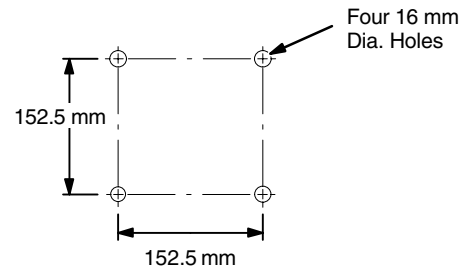
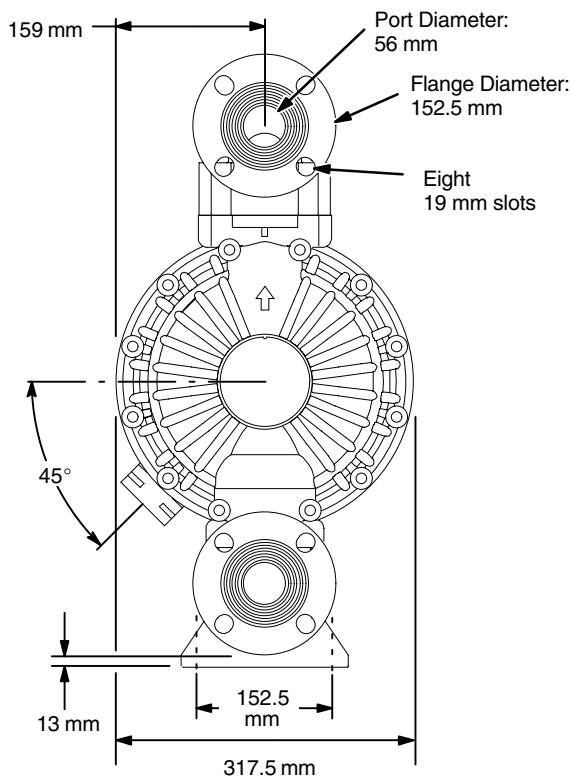

**PUMP MOUNTING HOLE PATTERN**

## Technical Data

Maximum Fluid Working Pressure ..... 8.3 bar  
 Air Pressure Operating Range ..... 1.4–8.3 bar  
 Maximum Air Consumption ..... 4.9 N m<sup>3</sup>/min  
 Air Consumption  
 at 4.9 bar/227 l/min ..... 1.68 N m<sup>3</sup>/min (see chart)  
 Maximum Free Flow Delivery ..... 568 l/min  
 Maximum Pump Speed ..... 145 cpm  
 Liters per cycle ..... 3.90  
 Maximum Suction Lift ..... 5.48 m wet or dry  
 Maximum Size Pumpable Solids ..... 6.3 mm  
 \* Sound pressure Level at 7 bar, 50 cpm ..... 90 dBA  
 \* Sound Power Level at 7 bar, 50 cpm ..... 103 dBA  
 \* Sound Pressure Level at 4.9 bar, 50 cycles/min .... 85 dBA  
 Maximum Operating Temperature ..... 65.5°C  
 Air Inlet Size ..... 1/2 npt(f)  
 Fluid Inlet Size ..... 2 in. Raised Face Flange

Fluid Outlet Size ..... 2 in. Raised Face Flange  
 Wetted Parts ..... Vary by Model. Refer to pages 24–27  
 Non-wetted External Parts ..... Aluminum,  
 302, 316 Stainless Steel, Polyester (labels)  
 Weight ..... Polypropylene Pumps  
 with Aluminum Air Section: 22 kg  
 ..... PVDF Pumps  
 with Aluminum Air Section: 31 kg  
 ..... Polypropylene Pumps  
 with Stainless Steel Air Section: 32 kg  
 ..... PVDF Pumps  
 with Stainless Steel Air Section: 41 kg

Santoprene® is a registered trademark of the Monsanto Co.  
 \* Sound pressure levels measured with the pump mounted on the floor, using Rubber Foot Kit 819.4333. Sound power measured per ISO Standard 9614–2.

### Example of Finding Pump Air Consumption and Air Pressure at a Specific Fluid Delivery and Discharge Head:

To supply 227 liters fluid flow (horizontal scale) at 2.8 bar discharge head pressure (vertical scale) requires approximately 1.68 N m<sup>3</sup>/min air consumption at 4.9 bar inlet air pressure.

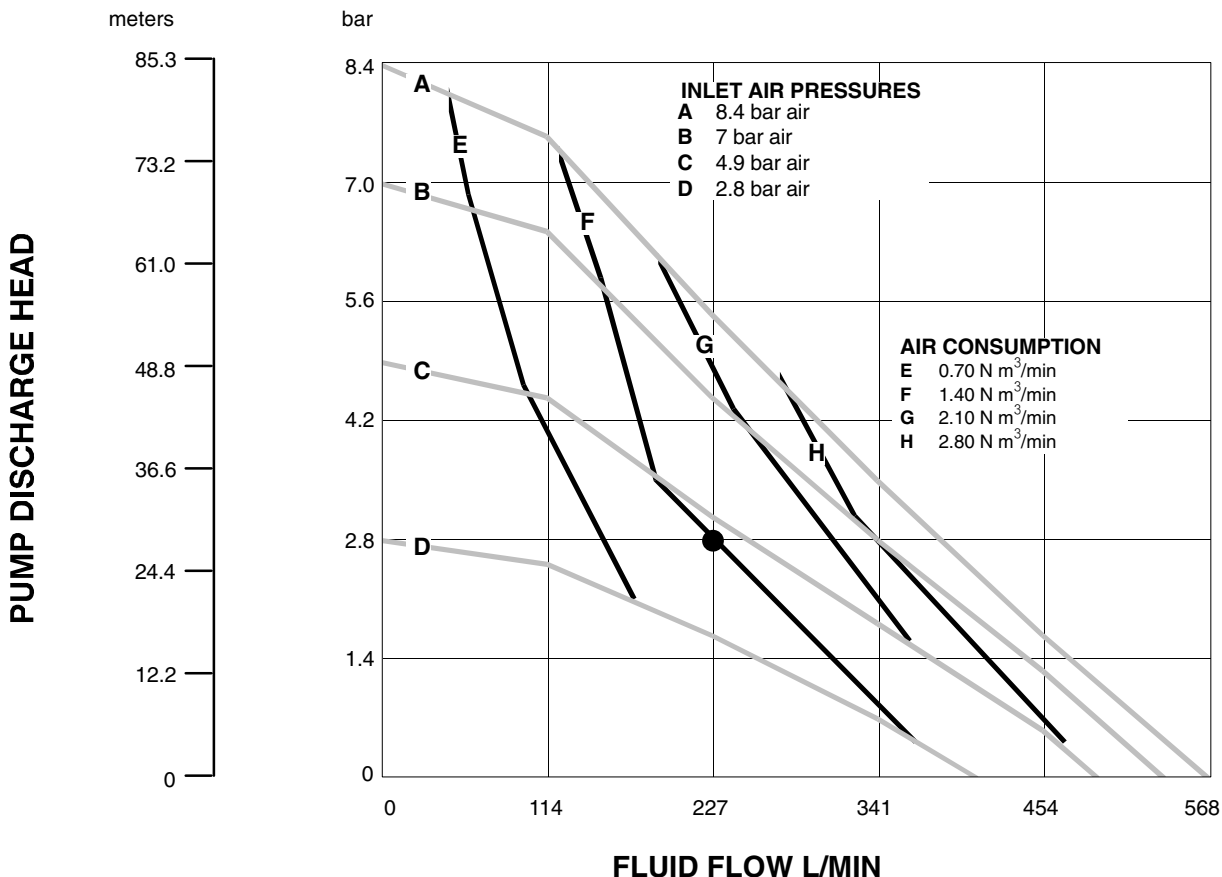

**TEST CONDITIONS**  
 Pump tested in water with PTFE diaphragm and inlet submerged.

**KEY** ——— FLUID PRESSURE AND FLOW  
 ——— N M<sup>3</sup>/MIN AIR CONSUMPTION

---

# Customer Services/Guarantee

## CUSTOMER SERVICES

If you require spare parts, please contact your local distributor, providing the following details:

- Pump Model
- Type
- Serial Number, and
- Date of First Order.

## GUARANTEE

All VERDER pumps are warranted to the original user against defects in workmanship or materials under normal use (rental use excluded) for two years after purchase date. This warranty does not cover failure of parts or components due to normal wear, damage or failure which in the judgement of VERDER arises from misuse.

Parts determined by VERDER to be defective in material or workmanship will be repaired or replaced.

## LIMITATION OF LIABILITY

To the extent allowable under applicable law, VERDER's liability for consequential damages is expressly disclaimed. VERDER's liability in all events is limited and shall not exceed the purchase price.

## WARRANTY DISCLAIMER

VERDER has made an effort to illustrate and describe the products in the enclosed brochure accurately; however, such illustrations and descriptions are for the sole purpose of identification and do not express or imply a warranty that the products are merchantable, or fit for a particular purpose, or that the products will necessarily conform to the illustration or descriptions.

## PRODUCT SUITABILITY

Many regions, states and localities have codes and regulations governing the sale, construction, installation and/or use of products for certain purposes, which may vary from those in neighbouring areas. While VERDER attempts to assure that its products comply with such codes, it cannot guarantee compliance, and cannot be responsible for how the product is installed or used. Before purchasing and using a product, please review the product application as well as the national and local codes and regulations, and be sure that product, installation, and use complies with them.

**VERDER**

# EC-DECLARATION OF CONFORMITY

EG-VERKLARING VAN OVEREENSTEMMING, DÉCLARATION DE CONFORMITÉ CE, EG-KONFORMITÄTSEKTLÄRUNG, DICHIARAZIONE DI CONFORMITÀ CE, EF-OVERENSSTEMMELSESEKTLÆRING, EK-ΔΗΛΩΣΗ ΣΥΜΜΟΡΦΩΣΗΣ, DECLARAÇÃO DE CONFORMIDADE - CE, DECLARACIÓN DE CONFORMIDAD DE LA CE, EY-VAATIMUSTENMUKAISUUSVAKUUTUS, EG-DEKLARATION OM ÖVERENSSTÄMMELSE, ES PROHLÁŠENÍ O SHODĚ, EÜ VASTAVUSDEKLARATSIOON, EC MEGFEJELŐSÉGI NYILATKOZAT, EK ATBILSTÍBAS DEKLARACIJA, ES ATITIKTIES DEKLARACIJA, DEKLARACIJA ZGODNOSTI UE, DIKJARAZZJONI-KE TA' KONFORMITA', IZJAVA ES O SKLADNOSTI, ES - VYHLÁSENIE O ZHODE, EO-DEKLARACIJA ZA SЪBMECTIMOST, DEIMHNIÚ COMHREIREACHTA CE, CE-DECLARAȚIE DE CONFORMITATE

## Model

**VERDERAIR VA 50**

Modèle, Modell, Modello, Μοντέλο,  
Modelo, Malli, Mudel, Modelis, Mudell, Модел, Samhail

## Part

Bestelnr., Type, Teil, Codice, Del, Μέρος, Peça,  
Referencia, Osa, Součást, Részegység, Daja,  
Dalis, Część, Taqsima, Čast, Част, Páirt, Parte

810.0105–810.0107, 810.0114–810.0117, 810.0120, 810.0182, 810.0187,  
810.3937–810.4080, 810.4129–810.4272, 810.6989, 810.7028, 810.7029,  
810.7036, 810.7043–810.7045, 810.7062–810.7065

## Complies With The EC Directives:

Voldoet aan de EG-richtlijnen, Conforme aux directives CE, Entspricht den EG-Richtlinien, Conforme alle direttive CE, Overholder EF-direktiverne, Σύμφωνα με τις Οδηγίες της ΕΚ, Em conformidade com as Directivas CE, Cumple las directivas de la CE, Täyttää EY-direktiivien vaatimukset, Oppfyller EG-direktiven, Shoda se směrnicemi ES, Vastab EÜ direktiividele, Kielégíti az EK irányelvek követelményeit, Atbilst EK direktīvām, Atitinka šias ES direktyvas, Zgodnošč z Dyrektywami UE, Konformi mad-Direttivi tal-KE, V skladu z direktivami ES, Je v súlade so smernicami ES, Съвместимост с Директиви на ЕО, Tá ag teacht le Treoracha an CE, Respectă directivele CE

2006/42/EC Machinery Directive

## Standards Used:

Gebruikte maatstaven, Normes respectées, Verwendete Normen, Norme applicate, Anvendte standarder, Πρότυπα που χρησιμοποιήθηκαν, Normas utilizadas, Normas aplicadas, Sovellettavat standardit, Tillämpade standarder, Použité normy, Rakendatud standardid, Alkalmazott szabványok, Izmantotie standarti, Taikyti standartai, Užyte normy, Standards Užati, Uporabljeni standardi, Použité normy, Използвани стандарти, Caidheáin arna n-úsáid, Standarde utilizate

ISO 12100

ISO 9614-1

## Notified Body for Directive

Aangemelde instantie voor richtlijn, Organisme notifié pour la directive, Benannte Stelle für diese Richtlinie, Ente certificatore della direttiva, Bemyndiget organ for direktiv, Διακοινωμένο όργανο Οδηγίας, Organismo notificado relativamente à directiva, Organismo notificado de la directiva, Direktiivin mukaisesti ilmoitettu tarkastuslaitos, Anmält organ för direktivet, Úředně oznámený orgán pro směrnici, Teavitatud asutus (direktiivi järgi), Az irányelvek kapcsolatban értesített testület, Piilvarotā iestāde saskaņā ar direktīvu, Apie direktīvą Informuota institucija, Ciało powiadomione dla Dyrektywy, Korp avzat bid-Direttiva, Priglašeni organ za direktivo, Notifikovaný orgán pre smernicu, Нотифициран орган за Директива, Comhlacht ar tugadh fógra dó, Organism notificat în conformitate cu directiva

## Approved By:

Goedgekeurd door, Approuvé par, Genehmigt von, Approvato da, Godkendt af, Έγκριση από, Aprovado por, Aprobado por, Hyväksynyt, Intygas av, Schwáilil, Kinnitanud, Jóváhagyta, Apstiprināts, Patvirtino, Zatwierdzone przez, Approvat minn, Odobril, Schwálené, Одобрено от, Faofa ag, Aprobat de

Frank Meersman  
Director

29 December 2009

VERDER NV  
Kontichsesteenweg 17  
B-2630 Aartselaar  
BELGIUM

819.5962



**VERDER**

# EC-DECLARATION OF CONFORMITY

EG-VERKLARING VAN OVEREENSTEMMING, DÉCLARATION DE CONFORMITÉ CE, EG-KONFORMITÄTSERKLÄRUNG, DICHIARAZIONE DI CONFORMITÀ CE, EF-OVERENSSTEMMELSESERKLÆRING, ΕΚ-ΔΗΛΩΣΗ ΣΥΜΜΟΡΦΩΣΗΣ, DECLARAÇÃO DE CONFORMIDADE - CE, DECLARACIÓN DE CONFORMIDAD DE LA CE, EY-VAATIMUSTENMUKAISUUSVAKUUTUS, EG-DEKLARATION OM ÖVERENSSTÄMMELSE, ES PROHLÁŠENÍ O SHODĚ, EÜ VASTAVUSDEKLARATSIOON, EC MEGFEIÉLŐSÉGI NYILATKOZAT, EK ATBILSTÍBAS DEKLARÁCIJA, ES ATITIKTIES DEKLARACIJA, DEKLARACJA ZGODNOŚCI UE, DIKJARAZZJONI-KE TA' KONFORMITA', IZJAVA ES O SKLADNOSTI, ES - VYHLÁŠENIE O ZHODE, EO-ДЕКЛАРАЦИЯ ЗА СЪВМЕСТИМОСТ, DEIMHNIÚ COMHRÉIREACHTA CE, CE-DECLARAȚIE DE CONFORMITATE

## Model

**VERDERAIR VA 50**

Modèle, Modell, Modello, Μοντέλο,  
Modelo, Malli, Mudel, Modelis, Mudell, Модел, Samhail

## Part

Bestelnr., Type, Teil, Codice, Del, Μέρος, Peça,  
Referencia, Osa, Součást, Részegység, Daja,  
Dalis, Część, Taqsima, Čast, Част, Páirt, Parte

810.0108–810.0113, 810.0118, 810.0119, 810.0448-810.0464,  
810.2246–810.2366, 810.2368–810.2399, 810.2401–810.2510,  
810.2512–810.2538, 810.2543–810.2547, 810.4081–810.4128,  
810.6356–810.6476, 810.6484–810.6531, 810.6990–810.6994,  
810.7030–810.7035, 810.7037, 810.7070, 810.7072

## Complies With The EC Directives:

Voldoet aan de EG-richtlijnen, Conforme aux directives CE, Entspricht den EG-Richtlinien, Conforme alle direttive CE, Overholder EF-direktiverne, Σύμφωνα με τις Οδηγίες της ΕΚ, Em conformidade com as Directivas CE, Cumples las directivas de la CE, Täyttää EY-direktiivien vaatimukset, Uppfyller EG-direktiven, Shoda se směrnicemi ES, Vastab EÜ direktiividele, Kielégíti az EK irányelvek követelményeit, Atbilst EK direktīvām, Atitinka šias ES direktyvas, Zgodność z Dyrektywami UE, Konformi mad-Direttivi ta-KE, V skladu z direktivami ES, Je v súlade so smernicami ES, Съвместимост с Директиви на ЕО, Tá ag teacht le Treoracha an CE, Respectă directivele CE

2006/42/EC Machinery Directive94/9/EC ATEX Directive (EX II 2 GD c IIC T4) – Tech File stored with NB 0359

## Standards Used:

Gebruikte maatstaven, Normes respectées, Verwendete Normen, Norme applicate, Anvendte standarder, Πρότυπα που χρησιμοποιήθηκαν, Normas utilizadas, Normas aplicadas, Sovellettavat standardit, Tillämpade standarder, Použité normy, Rakendatud standardid, Alkalmazott szabványok, Izmantotie standarti, Taikyti standartai, Uzyte normy, Standards Uzati, Uporabljeni standardi, Použité normy, Използвани стандарти, Caihdeáin arna n-úsáid, Standarde utilizate

EN 1127-1EN 13463-1ISO 12100ISO 9614-1

## Notified Body for Directive

Aangemelde instantie voor richtlijn, Organisme notifié pour la directive, Benannte Stelle für diese Richtlinie, Ente certificatore della direttiva, Bemyndiget organ for direktiv, Διακοινωμένο όργανο Οδηγίας, Organismo notificado relativamente à directiva, Organismo notificado de la directiva, Direktiivin mukaisesti ilmoitettu tarkastuslaitos, Anmält organ för direktivet, Úředně oznámený orgán pro směrnici, Teavitatud asutus (direktiivi järgi), Az irányelvel kapcsolatban értesített testület, Pilnvarotā iestāde saskaņā ar direktīvu, Apie direktīvu Informuota institūcija, Ciało powiadomione dla Dyrektywy, Korp avzat bid-Direttiva, Priglašeni organ za direktivo, Notifikovaný orgán pre smernicu, Нотифициран орган за Директива, Comhlacht ar tugadh fógra dó, Organism notificat în conformitate cu directiva

## Approved By:

Goedgekeurd door, Approuvé par, Genehmigt von, Approvato da, Godkendt af, Έγκριση από, Aprobado por, Aprobado por, Hyväksynyt, Intygas av, Schwáilil, Kinnitanud, Jónáhagya, Apstiprināts, Patvirtino, Zatwierdzone przez, Approvat minn, Odobril, Schválené, Одобрено от, Faofa ag, Aprobat de



**Frank Meersman**  
Director

29 December 2009

VERDER NV  
Kontichsesteenweg 17  
B-2630 Aartselaar  
BELGIUM

**819.5962**

**Austria**

Verder Austria  
Eitnergasse 21/Top 8  
A-1230 Wien  
AUSTRIA  
Tel: +43 1 86 51 074 0  
Fax: +43 1 86 51 076  
e-mail: office@verder.at

**Belgium**

Verder nv  
Kontichsesteenweg 17  
B-2630 Aartselaar  
BELGIUM  
Tel: +32 3 877 11 12  
Fax: +32 3 877 05 75  
e-mail: info@verder.be

**China**

Verder Retsch Shanghai Trading  
Room 301, Tower 1  
Fuhai Commercial Garden no 289  
Bisheng Road, Zhangjiang  
Shanghai 201204  
CHINA  
Tel: +86 (0)21 33 93 29 50 / 33 93 29 51  
Fax: +86 (0)21 33 93 29 55  
e-mail: info@verder.cn

**Czech Republic**

Verder s.r.o.  
Vodnanská 651/6 (vchod Chlu-  
mecka 15)  
198 00 Praha 9-Kyje  
CZECH REPUBLIC  
Tel: +420 261 225 386-7  
Web: <http://www.verder.cz>  
e-mail: info@verder.cz

**Denmark**

Verder A/S  
H.J. Holstvej 26  
DK 2610 Rodovre  
DENMARK  
Tel: +45 3636 4600  
e-mail: info@verder.dk

**France**

Verder France  
Parc des Bellevues  
Rue du Gros Chêne  
F-95610 Eragny sur Oise  
FRANCE  
Tel: +33 134 64 31 11  
Fax: +33 134 64 44 50  
e-mail: verder-info@verder.fr

**Germany**

Verder Deutschland GmbH  
Retsch-Allee 1-5  
42781 Haan  
GERMANY  
Tel: 02104/2333-200  
Fax: 02104/2333-299  
e-mail: info@verder.de

**Hungary**

Verder Hungary Kft  
Budafoke ut 187 – 189  
HU-1117 Budapest  
HUNGARY  
Tel: 0036 1 3651140  
Fax: 0036 1 3725232  
e-mail: info@verder.hu

**The Netherlands**

Verder BV  
Leningradweg 5  
NL 9723 TP Groningen  
THE NETHERLANDS  
Tel: +31 50 549 59 00  
Fax: +31 50 549 59 01  
e-mail: info@verder.nl

**Poland**

Verder Polska  
ul.Ligonia 8/1  
PL-40 036 Katowice  
POLAND  
Tel: +48 32 78 15 032  
Fax: +48 32 78 15 034  
e-mail: verder@verder.pl

**Romania**

Verder România  
Drumul Balta Doamnei no  
57-61  
Sector 3  
CP 72-117  
032624 Bucuresti  
ROMANIA  
Tel: +40 21 335 45 92  
Fax: +40 21 337 33 92  
e-mail: office@verder.ro

**Slovak Republic**

Verder Slovakia s.r.o.  
Silacska 1  
SK-831 02 Bratislava  
SLOVAK REPUBLIC  
Tel: +421 2 4463 07 88  
Fax: +421 2 4445 65 78  
e-mail: info@verder.sk

**South Africa**

Verder SA  
197 Flaming Rock Avenue  
Northlands Business Park  
Newmarket Street  
ZA Northriding  
SOUTH AFRICA  
Tel: +27 11 704 7500  
Fax: +27 11 704 7515  
e-mail: info@verder.co.za

**Switzerland**

Verder AG  
Auf dem Wolf 19  
CH-4052 Basel  
SWITZERLAND  
Tel: +41 (0)61 373 7373  
e-mail: info@verder.ch

**United Kingdom**

Verder Ltd.  
Whitehouse Street  
GB-Hunslet, Leeds LS10 1AD  
UNITED KINGDOM  
Tel: +44 113 222 0250  
Fax: +44 113 246 5649  
e-mail: info@verder.co.uk

**United States of America**

Verder Inc.  
110 Gateway Drive  
Macon, GA 31210  
USA  
Toll Free: 1 877 7 VERDER  
Tel: +1 478 471 7327  
Fax: +1 478 476 9867  
e-mail: info@verder.com