

cylinders

GeoMetric® Series

VDMA 24562, DIN/ISO 6431, and ISO 15552



NUMATICS®

Table of Contents

GeoMetric® <i>Cylinders</i>	3-20
How to Order	3
Double acting, Piston diameter 32 to 100 mm	4-5
Locking Units	6-7
Mounting Parts	8-15
Switches and Sensors	16
Brackets for Switches and Sensors / Leads	17
Technical Information	18-20



How to Order

G G 050 / 0080 000 00

Cylinder Series
G = GeoMetric® (Profile Tube)

Cylinder Type
A = High temperature (Viton®) option +284° F, single rod end w/o magnetic piston
B = High temperature (Viton®) option +284° F, double rod end w/o magnetic piston
C = Low temperature option -22° F, single rod end with magnetic piston
D = Low temperature option -22° F, double rod end with magnetic piston
G = Single rod end with magnetic piston
H = Double rod end with magnetic piston

Note: G is the most popular - faster lead time.

Bore Size
032 = 32 mm
040 = 40 mm
050 = 50 mm
063 = 63 mm
080 = 80 mm
100 = 100 mm

Ports
/ = BSPP Ports

Options*
00 = w/o options (rod is chrome plated steel)
A2 = Stainless steel piston rod (AISI 303)
E1 = Cylinder w/o cushioning
N2 = Grease for food processing
* Further options on request

Cylinder Mount
000 = Cylinder w/o mounting parts
C01 = Foot bracket (outside) to VDMA 24562 T.2 (MS)
CF2 = Flange (front side) to VDMA 24562 T.2 (MF1, MF2)
CR2 = Flange (back side) to VDMA 24562 T.2 (MF1, MF2)
C03 = Foot bracket (plain)
CF4 = Rod clevis (front side) to DIN/ISO and VDMA
CD4 = Rod clevis (only type H, B, and D)
CF5 = Oscillating clevis (front side)
CD5 = Oscillating clevis (both side) (only type H, B, and D)
C07 = Oscillating bracket (with lugs) to VDMA 24562 T.2 (MP4)
C08 = Oscillating bracket (fork type) to VDMA 24562 T.2 (MP2)
C13 = Oscillating joint bracket (spherical)
C14 = Oscillating bracket, narrow clevis fork type to VDMA 24562 T.2 (MP2)
BOV* = With extended piston rod for future mounting of locking unit (A2 option required)
BMV* = Locking units mounted to cylinder (A2 option required)

* RL Series locking units not available with the following cylinder types: "A"; "B"; "C" and "D"

Standard Stroke*
0025 = 25 mm
0032 = 32 mm
0040 = 40 mm
0050 = 50 mm
0063 = 63 mm
0080 = 80 mm
0100 = 100 mm
0125 = 125 mm
0160 = 160 mm
0200 = 200 mm
0250 = 250 mm
0320 = 320 mm
0400 = 400 mm
0500 = 500 mm

*Consult factory for non-standard stroke lengths.

The GeoMetric® cylinder line comes standard with Adjustable Cushions.

Order example: GG050/0080000000

This refers to a double acting GeoMetric® cylinder with single rod end. Cylinder bore is 50 mm and stroke is 80 mm. The cylinder is equipped with a magnetic piston for proximity switching and adjustable cushions.

Weights (kg)

Cylinder Type GA, GC, or GG	Bore					
	32	40	50	63	80	100
0 mm stroke	1.24	1.98	3.09	3.97	6.40	9.70
To be added per 100 mm stroke	0.66	0.88	1.10	1.30	2.07	2.23

Cylinder Type GB, GD, or GH	Bore					
	32	40	50	63	80	100
0 mm stroke	1.43	2.25	3.53	4.63	7.10	10.80
To be added per 100 mm stroke	0.84	1.24	1.54	1.81	2.91	3.20

Conversions

kg X 2.205 = lbs.
Bars X 14.50 = psi
(1.8° C) + 32 = °Fahrenheit



Double Acting Cylinder with Magnetic Piston

Single Rod End, Types GC, GA, or GG

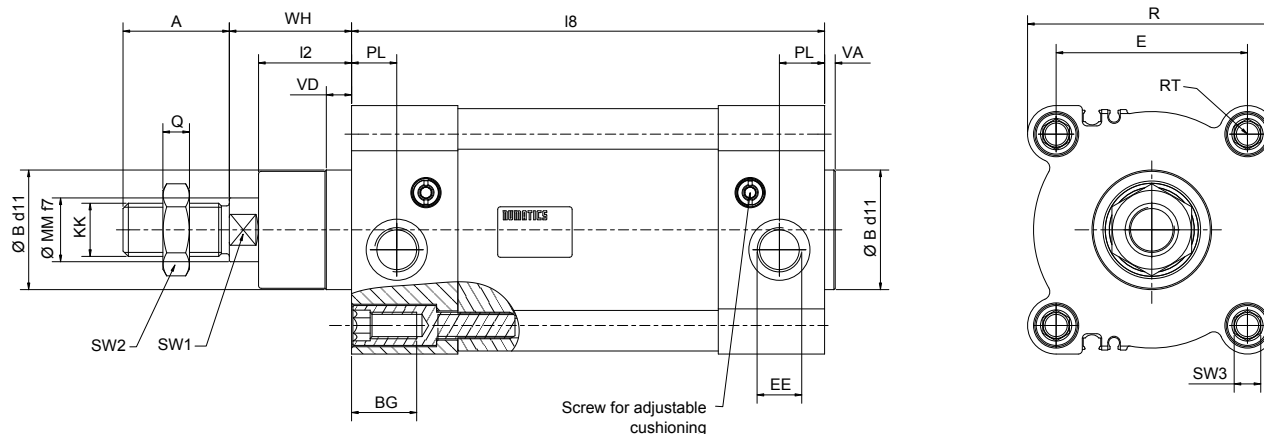

X = cushioning length

Single Rod

Bore Size	Standard Seal Kit Part Number	Viton® Seal Kit Part Number
32	GG032/RK	GA032/RK
40	GG040/RK	GA040/RK
50	GG050/RK	GA050/RK
63	GG063/RK	GA063/RK
80	GG080/RK	GA080/RK
100	GG100/RK	GA100/RK

NOTE: Seal kit includes: 1 Piston, 2 Tube End Seals, 2 Cushion Seals, and 1 Rod Seal

Dimensions (mm)

Type	Bore Size	A	B d11	BG	E	EE	KK	I2	I8	MM f7	PL
GA, GC, GG	32	22.0	30.0	18	32.5	G 1/8	M10x1.25	18.0	93.0	12.0	14.5
GA, GC, GG	40	24.0	35.0	18	38.0	G 1/4	M12x1.25	22.0	105.0	16.0	15.0
GA, GC, GG	50	32.0	40.0	20	46.5	G 1/4	M16x1.5	25.5	106.0	20.0	13.5
GA, GC, GG	63	32.0	45.0	20	56.5	G 3/8	M16x1.5	25.0	121.0	20.0	17.0
GA, GC, GG	80	40.0	45.0	26	72.0	G 3/8	M20x1.5	35.0	128.0	25.0	17.0
GA, GC, GG	100	40.0	55.0	26	89.0	G 1/2	M20x1.5	38.0	138.0	25.0	18.0

Dimensions (mm)

Type	Bore Size	Q	R	RT	SW1	SW2	SW3	VA	VD	WH	X
GA, GC, GG	32	5.0	47.0	M6	10	17	6	4.0	9.5	26.0	28
GA, GC, GG	40	6.0	54.0	M6	13	19	6	4.0	9.5	30.0	30
GA, GC, GG	50	8.0	63.0	M8	16	24	8	4.0	9.5	37.0	32
GA, GC, GG	63	8.0	74.5	M8	16	24	8	4.0	9.5	37.0	32
GA, GC, GG	80	10.0	93.5	M10	21	30	10	4.0	10.0	46.0	32
GA, GC, GG	100	10.0	110.5	M10	21	30	10	4.0	10.0	51.0	32



Double Acting Cylinder with Magnetic Piston

Double Rod End, Types GB, GD, or GH

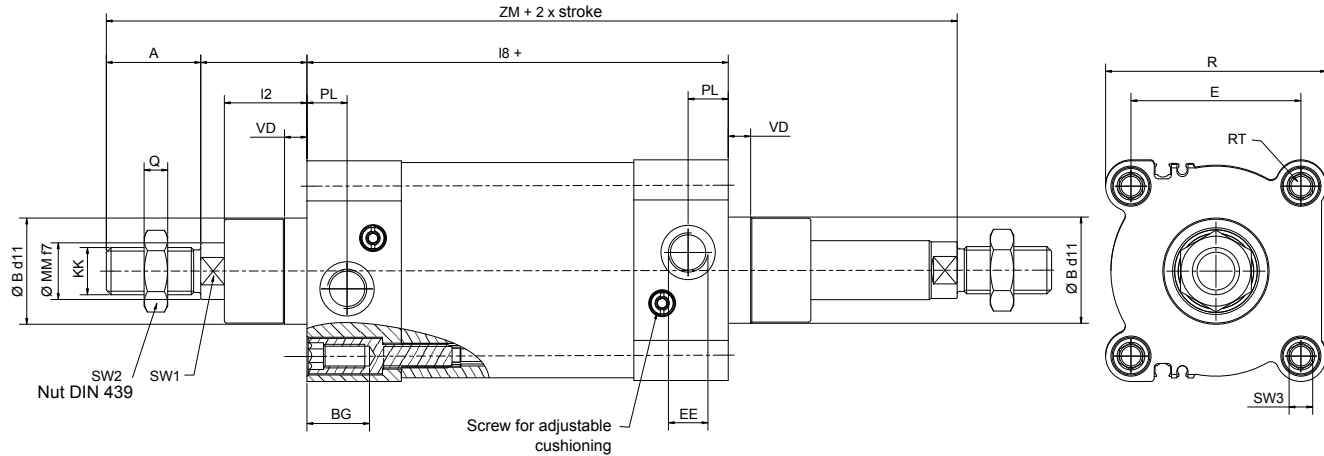

X = cushioning length

Double Rod

Bore Size	Standard Seal Kit Part Number	Viton® Seal Kit Part Number
32	GH032/RK	GB032/RK
40	GH040/RK	GB040/RK
50	GH050/RK	GB050/RK
63	GH063/RK	GB063/RK
80	GH080/RK	GB080/RK
100	GH100/RK	GB100/RK

NOTE: Seal kit includes: 1 Piston, 2 Tube End Seals, 2 Cushion Seals, and 2 Rod Seal.

Dimensions (mm)

Type	Bore Size	A	B d11	BG	E	EE	KK	I2	I8	MM f7	PL
GB, GD, GH	32	22.0	30.0	18	32.5	G 1/8	M10x1.25	18.0	94.0	12.0	14.5
GB, GD, GH	40	24.0	35.0	18	38.0	G 1/4	M12x1.25	22.0	105.0	16.0	15.0
GB, GD, GH	50	32.0	40.0	20	46.5	G 1/4	M16x1.5	25.5	106.0	20.0	13.5
GB, GD, GH	63	32.0	45.0	20	56.5	G 3/8	M16x1.5	25.0	121.0	20.0	17.0
GB, GD, GH	80	40.0	45.0	26	72.0	G 3/8	M20x1.5	35.0	128.0	25.0	17.0
GB, GD, GH	100	40.0	55.0	26	89.0	G 1/2	M20x1.5	38.0	138.0	25.0	18.0

Dimensions (mm)

Type	Bore Size	Q	R	RT	SW1	SW2	SW3	VD	WH	ZM	X
GB, GD, GH	32	5.0	47.0	M6	10	17	6	9.5	26.0	168.0	28
GB, GD, GH	40	6.0	54.0	M6	13	19	6	9.5	30.0	189.0	30
GB, GD, GH	50	8.0	63.0	M8	16	24	8	9.5	37.0	212.0	32
GB, GD, GH	63	8.0	74.5	M8	16	24	8	9.5	37.0	227.0	32
GB, GD, GH	80	10.0	93.5	M10	21	30	10	10.0	46.0	260.0	32
GB, GD, GH	100	10.0	110.5	M10	21	30	10	10.0	51.0	280.0	32



How to Order Accessories/Locking Units:

BMV / 050

Cylinder Type

BMV = With magnetic and proximity switching, max. 10 bar operation pressure, min. 4 bar release pressure, Clamping force: Cylinder force at 8 bar

For Cylinders with the following Bore Sizes

	Bore	Ports
032	= 32 mm	M5
040	= 40 mm	G 1/8
050	= 50 mm	G 1/8
063	= 63 mm	G 1/8
080	= 80 mm	G 1/8
100	= 100 mm	G 1/4

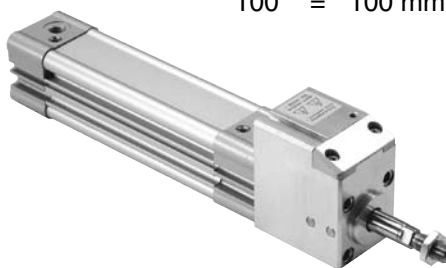

Order example: **BMV/050**

This refers to a locking unit for a cylinder with piston diameter of 50 mm. Port size of locking unit is G 1/8.

Note:

Locking units can be mounted to the cylinder.

(See order code on page 2, option BMV).

When cylinders and locking units are ordered separately, it has to be considered that the cylinder is ordered by indication of option BOV. (This means that the piston rod of the cylinder is already extended by dimension B.)

In case of self-assembly please note safety indications!

Technical Data		Material	
Ports:	M5, G 1/8 and G1/4	Housing material:	Anodized aluminum
Temperature range:	20 °C to +80 °C	Clamping jaws:	spring bronze
Operation pressure:	max. 10 bar	Gaskets:	NBR
Min. release pressure:	4 bar	Magnet:	Plastoferrite
Clamping force:	cylinder force at 8 bar	Spring:	stainless steel
Medium:	Air	Clamping jaw bearing:	stainless steel

Conversions

Bars X 14.50 = psi (1.8* °C) + 32 = °Fahrenheit

Warning:

The locking unit is not a safety element.

The user must take relevant safety precautions.



Spring tension within locking unit is very high!
Remove protection ring on piston only when release screw has been inserted and previously tightened.



Accessories/Locking Units

Locking Units, Simple Acting, with Magnetic and Proximity Switching

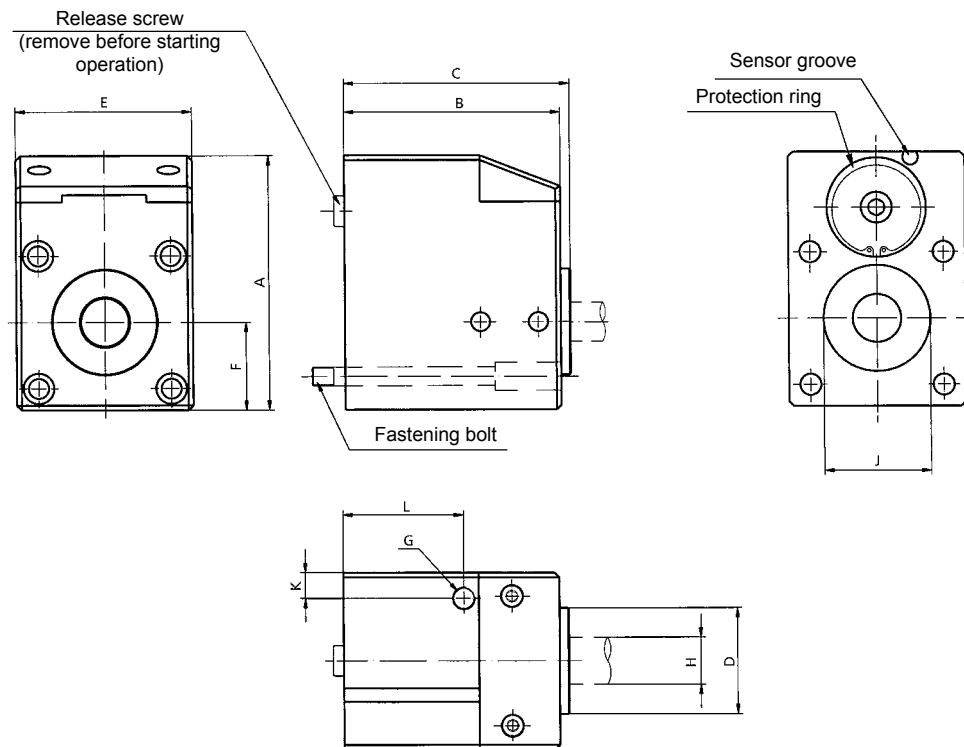

Dimensions (mm)

Type	Bore Size	A	B	C	D E11	E	F	G	H Ø	J ØH11	K	L	Weight approx. (kg)
BMV	32	70.0	60.0	64.0	30.0	47.0	23.5	M5	12.0	30.0	8.0	36.0	0.470
BMV	40	80.0	65.0	69.0	35.0	51.5	26.0	G 1/8	16.0	35.0	8.0	36.5	0.690
BMV	50	94.0	78.0	82.0	40.0	63.5	32.5	G 1/8	16.0	40.0	9.2	45.2	1.200
BMV	63	108.0	92.0	96.0	45.0	75.0	37.5	G 1/8	20.0	45.0	11.0	51.5	1.900
BMV	80	133.0	103.0	107.0	45.0	95.0	47.5	G 1/8	20.0	45.0	16.0	54.0	3.500
BMV	100	163.0	133.0	137.0	55.0	114.0	57.5	G 1/4	25.0	55.0	18.5	64.0	6.600

incl. fastening bolts for cylinder

Static Clamping Force

Bore Size (mm)	32	40	50	63	80	100
Piston rod diameter (mm)	12	12	16	16	20	25
Cylinder force at at 8 bar (N)	640	1000	1560	2490	4020	6280
Clamping force of locking unit (N)	650	1000	1600	2500	4200	6300

Note:

- Clamping force is purely static.
- When exceeding this load (even for a short time) slipping may occur!
- The piston rod to be clamped must be at least HRC 18.
- Nominal diameter of piston rod must be within tolerance f7 (ISO 286).
- Surface roughness R_{max} must be smaller than 4 μm .
- Patent number 19749477

Conversions

kg X 2.205 = lbs.
Bars X 14.50 = psi
(1.8* °C) + 32 = °Fahrenheit



RL Series Installation Instructions

1. Manual Override

The RL Series rod locking units are shipped with a manual override screw installed. This is the metric socket head cap screw shown on the back of the housing in the diagram below. The manual override allows the cylinder piston rod to be moved for setup of the machine the cylinder is utilized on. Once the cylinder and locking unit are in place, the screw can be loosened. To release the screw, first apply a minimum of 60 psi to the release supply port as shown in the diagram below. Loosen the screw by turning it counterclockwise. To reinstall the manual override, again apply air pressure and tighten the screw clockwise.

2. Normal Operation

With the manual override released and a minimum of 60 psi to the release supply port, the cylinder should stroke normally. If air pressure is lost to the release supply port, the spring in the locking unit will activate clamps to hold the cylinder from moving.

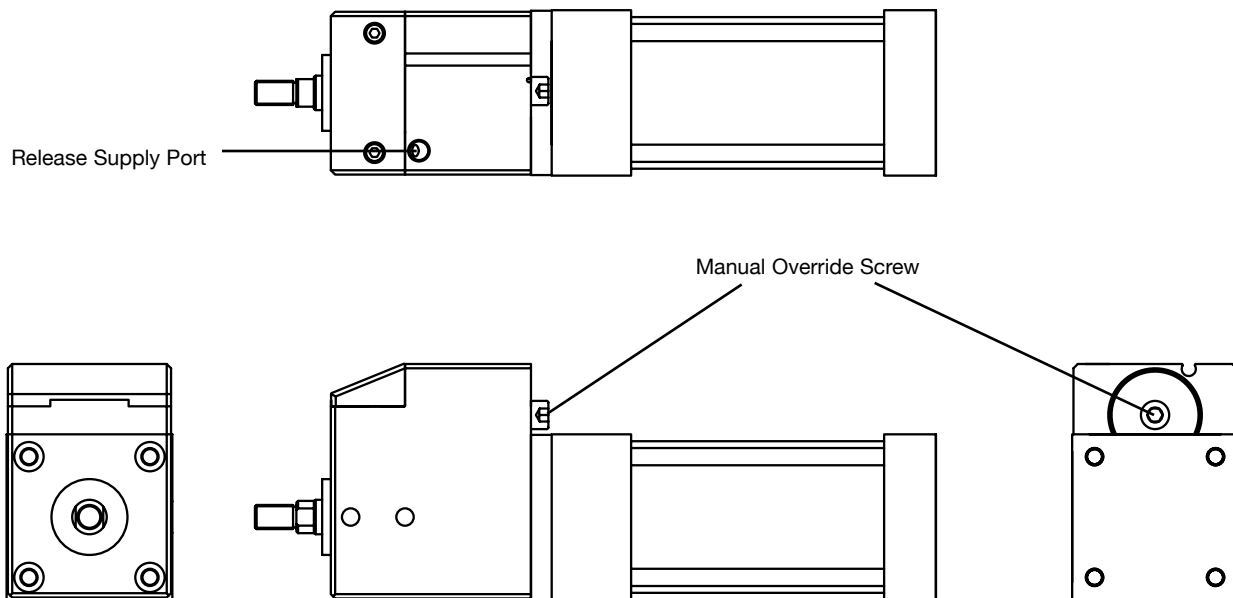

Warning:

The locking unit is not a safety element.
The user must take relevant safety precautions.

Spring tension within the locking unit is extremely high!
Remove protection ring on piston only when release screw has been inserted and previously tightened.



Accessories/Mounting Parts

Foot Brackets (outside) to VDMA 24562 T.2 (MS1)
for Cylinder with Piston Diameters 32 to 100 mm

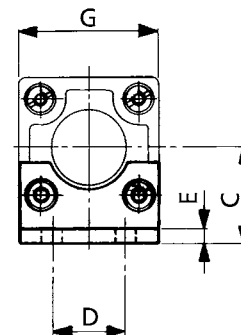
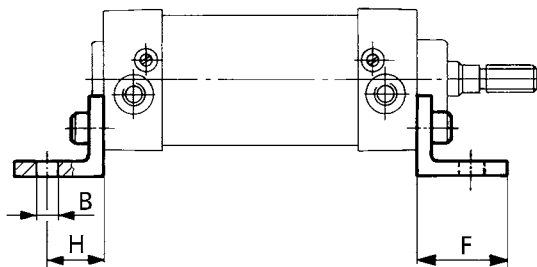

Dimensions (mm)

Bore	B Ø H14	C Js15	D Js14	E ±0.5	F	G -0.2	H ±0.2	Weight* approx. (kg)	Order Code Steel
32	7.0	32.0	32.0	4.0	35.0	45.0	24.0	0.130	VC01/032
40	9.0	36.0	36.0	4.0	36.0	52.0	28.0	0.160	VC01/040
50	9.0	45.0	45.0	5.0	47.0	65.0	32.0	0.340	VC01/050
63	9.0	50.0	50.0	5.0	45.0	75.0	32.0	0.380	VC01/063
80	12.0	63.0	63.0	6.0	55.0	95.0	41.0	0.765	VC01/080
100	14.0	71.0	75.0	6.0	57.0	115.0	41.0	0.905	VC01/100

incl. bolts

* per unit (= 2 foot brackets)

Material: steel

Front and Rear Flange to VDMA 24562 T.2 (MF1. MF2) for Cylinder with Piston Diameters 32 to 100 mm

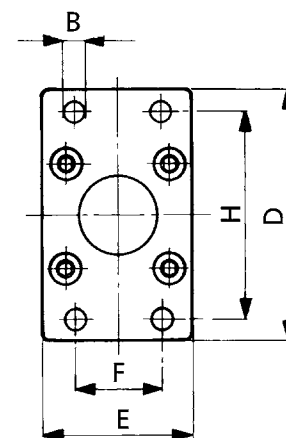
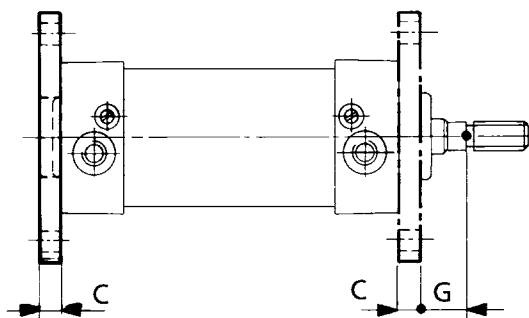

Dimensions (mm)

Bore	B H13	C ±0.2	D	E	F Js14	G	H Js14	Weight approx. (kg)	Order Code Steel
32	7.0	10.0	80.0	45.0	32.0	16.0	64.0	0.192	VC02/032
40	9.0	10.0	90.0	52.0	36.0	20.0	72.0	0.250	VC02/040
50	9.0	12.0	110.0	65.0	45.0	25.0	90.0	0.480	VC02/050
63	9.0	12.0	120.0	75.0	50.0	25.0	100.0	0.620	VC02/063
80	12.0	16.0	150.0	95.0	63.0	30.0	126.0	1.415	VC02/080
100	14.0	16.0	170.0	115.0	75.0	35.0	150.0	1.985	VC02/100

includes bolts

Material: steel

Conversions

kg X 2.205 = lbs.



Accessories/Mounting Parts

Foot Brackets (plain)

for Cylinders with Piston Diameters 32 to 100 mm

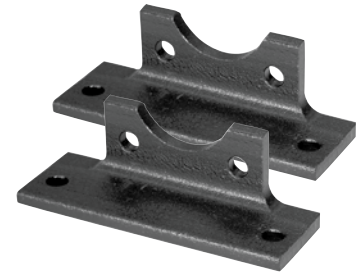
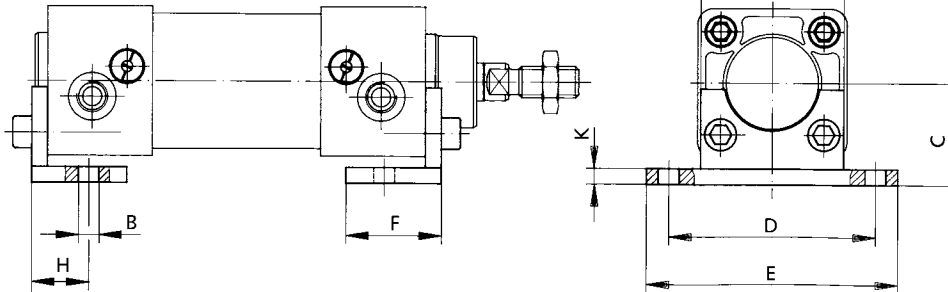

Dimensions (mm)

Bore	B Ø H14	C Js15	D Js14	E -0.2 +1	F +1	G ±0.2	H ±0.2	K ±0.3	Weight * approx. (kg)	Order Code Steel
32	6.5	32.0	65.0	79.0	30.0	45.0	18.0	5.0	0.270	VC03/032
40	6.5	36.0	75.0	90.0	30.0	55.0	18.0	5.0	0.295	VC03/040
50	8.5	45.0	90.0	110.0	35.0	65.0	21.0	5.0	0.435	VC03/050
63	8.5	50.0	100.0	120.0	35.0	75.0	21.0	5.0	0.475	VC03/063
80	10.5	63.0	128.0	153.0	45.0	95.0	27.0	6.0	0.975	VC03/080
100	10.5	71.0	148.0	178.0	45.0	115.0	27.0	6.0	1.160	VC03/100

includes bolts

* per unit (= 2 foot brackets)

Material: steel

Oscillating Brackets to VDMA 24562 T.2 (MP4) with Lugs

for Cylinder with Piston Diameters 32 to 100 mm

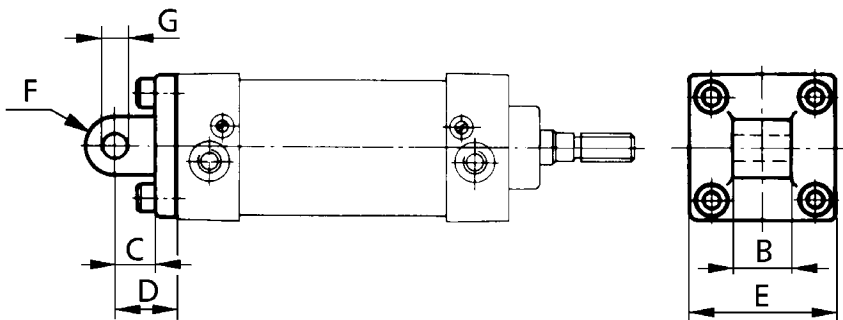

Dimensions (mm)

Bore	B	C -2 -6	D ±0.1	E	F	G H9	Weight approx. (kg)	Order Code Aluminum
32	26.0	13.0	22.0	45.0	10.0	10.0	0.140	VC07/032
40	28.0	16.0	25.0	52.0	12.0	12.0	0.230	VC07/040
50	32.0	16.0	27.0	65.0	12.0	12.0	0.336	VC07/050
63	40.0	21.0	32.0	75.0	16.0	16.0	0.546	VC07/063
80	50.0	22.0	36.0	95.0	16.0	16.0	1.190	VC07/080
100	60.0	27.0	41.0	115.0	20.0	20.0	1.840	VC07/100

includes bolts

Conversions

kg X 2.205 = lbs.

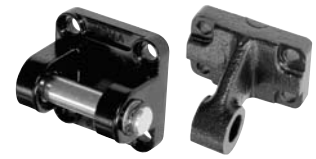

Accessories/Mounting Parts

Oscillating Brackets to VDMA 24562 T.2 (MP2) Fork Type
for Cylinders with Bore Sizes 32 to 100 mm

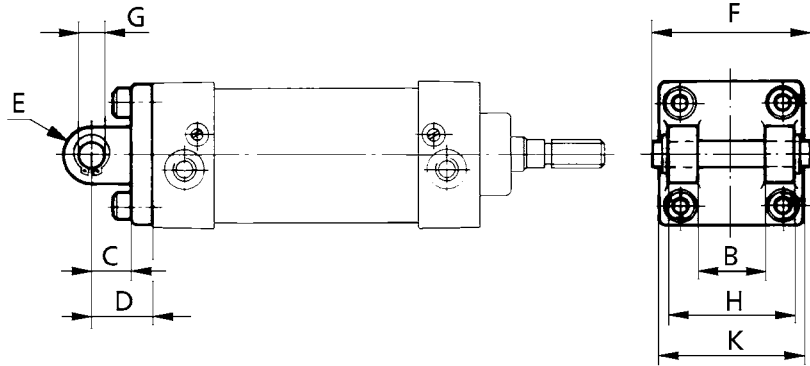

Dimensions (mm)

Bore	B H14	C	D ±0.2	E	F	G H9	H h14	K	Weight approx. (kg)	Order Code Aluminium/Steel
32	26.0	13.0	22.0	10.0	53.0	10.0	45.0	45.0	0.140	VC08/032-
40	28.0	16.0	25.0	12.0	60.0	12.0	52.0	55.0	0.230	VC08/040-
50	32.0	16.0	27.0	12.0	68.0	12.0	60.0	65.0	0.336	VC08/050-
63	40.0	21.0	32.0	16.0	78.0	16.0	70.0	75.0	0.546	VC08/063-
80	50.0	22.0	36.0	18.0	98.0	16.0	90.0	95.0	1.190	VC08/080-
100	60.0	27.0	41.0	20.0	118.0	20.0	110.0	115.0	1.840	VC08/100-

including pin and bolts

Material: Aluminum Standard, for Steel allow longer lead times; pin made from Steel

-A = Aluminum
-S = Steel

Right-angle Articulated Narrow Joint to VDMA 24562 T.2 (Cetop RP 107 P)
for Fitting to Rod Clevis SC4
for Cylinders with Bore Sizes 32 to 100 mm

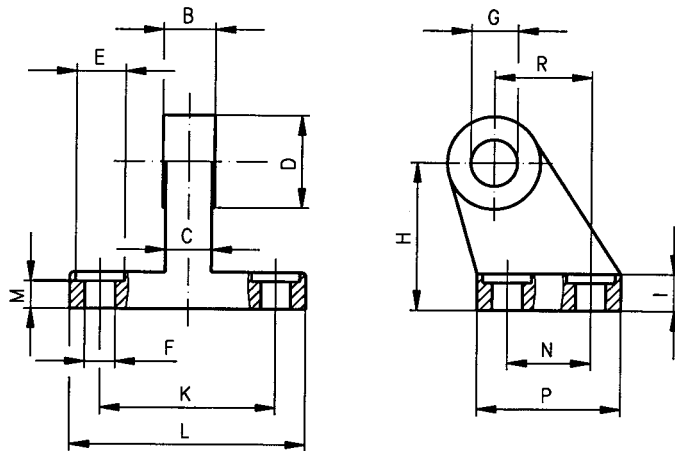

Dimensions (mm)

Bore	B	C	D	E	F	G	H	I	K	L	M	N	P	R	Weight approx. (kg)	Order Code Steel
Ø -0.2 -0.6	Ø	Ø	Ø	Ø	Ø	H9	Js15	Js14	Js14	L	M	N	P	Js14	approx. (kg)	Steel
32	26.0	10.0	20.0	11.0	6.6	10.0	32.0	8.0	38.0	51.0	7.5	18.0	31.0	21.0	0.158	VC10/032
40	28.0	10.0	22.0	11.0	6.6	12.0	36.0	10.0	41.0	54.0	8.5	22.0	35.0	24.0	0.238	VC10/040
50	32.0	14.0	26.0	15.0	9.0	12.0	45.0	12.0	50.0	65.0	10.5	30.0	45.0	33.0	0.418	VC10/050
63	40.0	14.0	30.0	15.0	9.0	16.0	50.0	12.0	52.0	67.0	10.5	35.0	50.0	37.0	0.526	VC10/063
80	50.0	18.0	30.0	18.0	11.0	16.0	63.0	14.0	66.0	86.0	11.5	40.0	60.0	47.0	1.055	VC10/080
100	60.0	20.0	36.0	18.0	11.0	20.0	71.0	15.0	76.0	96.0	12.5	50.0	70.0	55.0	1.360	VC10/100

Material: steel

Conversions

kg X 2.205 = lbs.



Accessories/Mounting Parts

Right-angle Articulated Joint to VDMA 24562 T.2 (Cetop RP 107 P)
for Cylinders with Piston Diameters 32 to 100 mm

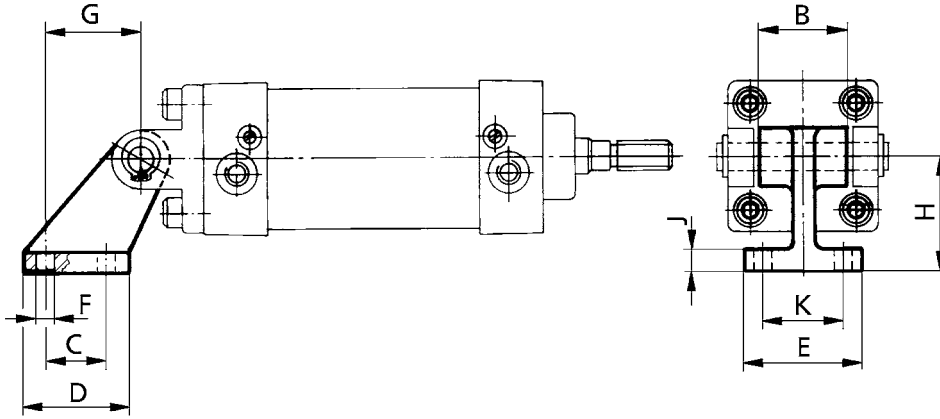

Dimensions (mm)

Piston Ø	B	C	D Js14	E	F Ø	G Js14	H Js15	J	K Js15	Weight approx. (kg)	Order Code Steel	Weight approx. (kg)	Order Code Aluminium
32	26.0	18.0	31.0	51.0	6.6	21.0	32.0	8.0	38.0	0.158	VC11/032-S	0.050	VC11/032-A
40	28.0	22.0	35.0	54.0	6.6	24.0	36.0	10.0	41.0	0.238	VC11/040-S	0.080	VC11/040-A
50	32.0	30.0	45.0	65.0	9.0	33.0	45.0	12.0	50.0	0.418	VC11/050-S	0.150	VC11/050-A
63	40.0	35.0	50.0	67.0	9.0	37.0	50.0	12.0	52.0	0.526	VC11/063-S	0.180	VC11/063-A
80	50.0	40.0	60.0	86.0	11.0	47.0	63.0	14.0	66.0	1.055	VC11/080-S	0.360	VC11/080-A
100	60.0	50.0	70.0	96.0	11.0	55.0	71.0	15.0	76.0	1.360	VC11/100-S	0.470	VC11/100-A

Material: Aluminum Standard, for Steel allow longer lead times; pin made from Steel

Right-angle Articulated Joint with Spherical Bushing to VDMA 24562 T.2
for Cylinders with Piston Diameters 32 to 100 mm

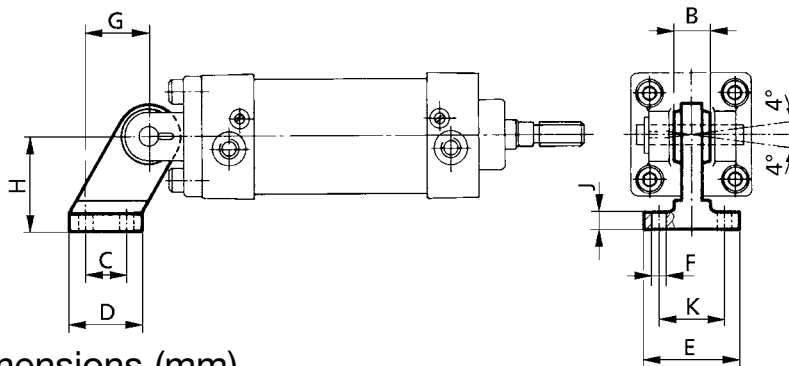

Dimensions (mm)

Piston Diameter	B -0.1	C Js14	D	E	F Ø	G Js14	H Js15	J	K Js14	Weight approx. (kg)	Order Code Steel
32	14.0	18.0	31.0	51.0	6.6	21.0	32.0	8.0	38.0	0.178	VC12/032
40	16.0	22.0	35.0	54.0	6.6	24.0	36.0	10.0	41.0	0.268	VC12/040
50	21.0	30.0	45.0	65.0	9.0	33.0	45.0	12.0	50.0	0.458	VC12/050
63	21.0	35.0	50.0	67.0	9.0	37.0	50.0	12.0	52.0	0.550	VC12/063
80	25.0	40.0	60.0	86.0	11.0	47.0	63.0	14.0	66.0	0.970	VC12/080
100	25.0	50.0	70.0	96.0	11.0	55.0	71.0	15.0	76.0	1.326	VC12/100

Material: steel

Conversions

kg X 2.205 = lbs.



Accessories/Mounting Parts

Oscillating Joint Bracket (Spherical) for Cylinders
with Piston Diameters 32 to 100 mm

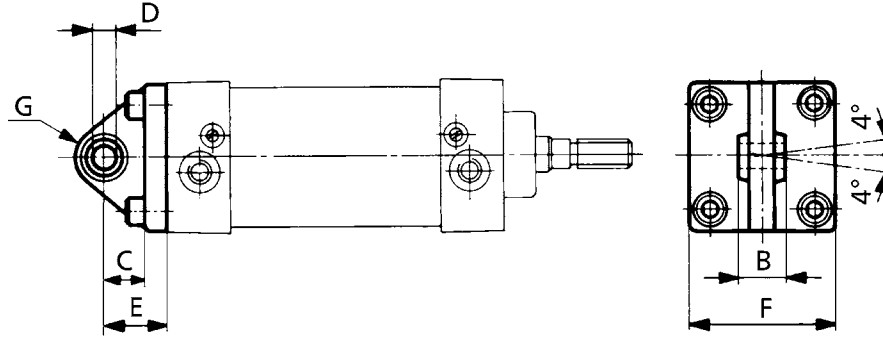

Dimensions (mm)

Piston Diameter	B -0.1	C	D H7	E Js15	F	G max.	Weight approx. (kg)	Order Code Steel	Weight approx. (kg)	Order Code Aluminium
32	14.0	12.0	10.0	22.0	45.0	15.0	0.210	VC13/032-S	0.100	VC13/032-A
40	16.0	15.0	12.0	25.0	55.0	18.0	0.280	VC13/040-S	0.110	VC13/040-A
50	21.0	17.0	16.0	27.0	65.0	20.0	0.430	VC13/050-S	0.160	VC13/050-A
63	21.0	20.0	16.0	32.0	75.0	23.0	0.680	VC13/063-S	0.250	VC13/063-A
80	25.0	20.0	20.0	36.0	95.0	27.0	1.220	VC13/080-S	0.460	VC13/080-A
100	25.0	25.0	20.0	41.0	115.0	30.0	2.030	VC13/100-S	0.760	VC13/100-A

incl. bolts

Material: Aluminum Standard, for Steel allow longer lead times; pin made from Steel

Oscillating Brackets to VDMA 24562 T.2 Fork Type Narrow Clevis for Cylinders with Piston Diameters 32 to 100 mm

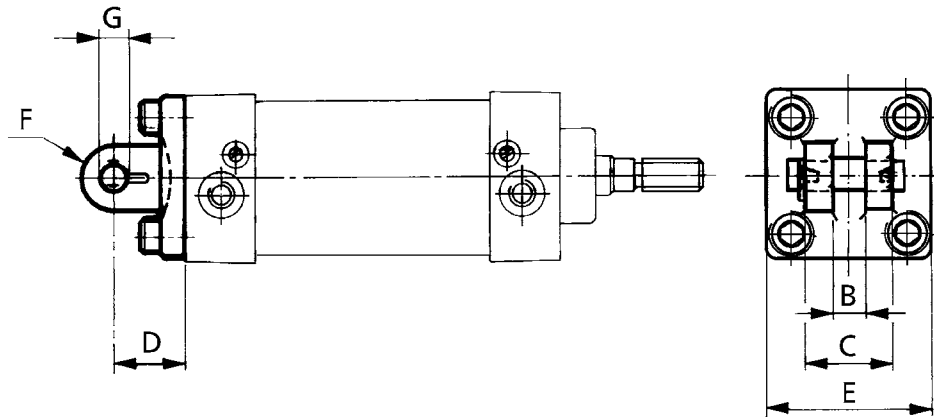

Dimensions (mm)

Piston Diameter	B H14	C	D ±0.2	E	F	G H7	Weight approx. (kg)	Order Code Steel	Weight approx. (kg)	Order Code Aluminium
32	14.0	34.0	22.0	45.0	11.0	10.0	0.220	VC14/032-S	0.140	VC14/032-A
40	16.0	40.0	25.0	55.0	13.0	12.0	0.290	VC14/040-S	0.230	VC14/040-A
50	21.0	45.0	27.0	65.0	18.0	16.0	0.480	VC14/050-S	0.340	VC14/050-A
63	21.0	51.0	32.0	75.0	18.0	18.0	0.680	VC14/063-S	0.540	VC14/063-A
80	25.0	65.0	38.0	95.0	22.0	20.0	1.380	VC14/080-S	1.200	VC14/080-A
100	25.0	75.0	41.0	115.0	22.0	20.0	2.100	VC14/100-S	1.800	VC14/100-A

incl. pin and bolts

Material: Aluminum Standard, for Steel allow longer lead times; pin made from Steel

Conversions

kg X 2.205 = lbs.



Accessories/Mounting Parts

Rod Clevis

for Cylinders with Piston Diameters 32 to 100 mm

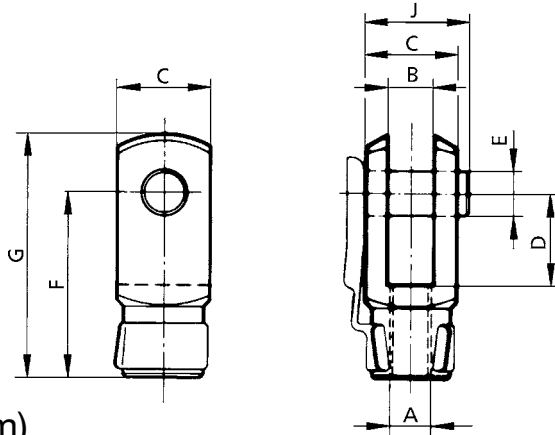

Dimensions (mm)

Piston Diameter	A	B	C	D	E	F	G	J	Weight approx. (kg)	Order Code Steel
32	M10x1.25	10.0	20.0	20.0	10.0	40.0	52.0	23.0	0.090	SC4/025
40	M12x1.25	12.0	24.0	24.0	12.0	48.0	62.0	28.0	0.150	SC4/040
50/63	M16x1.5	16.0	32.0	32.0	16.0	64.0	83.0	36.0	0.340	SC4/050
80/100	M20x1.5	20.0	40.0	40.0	20.0	80.0	105.0	44.0	0.690	SC4/080

Material: galvanized steel

Oscillating Clevis

for Cylinders with Piston Diameters 32 to 125 mm

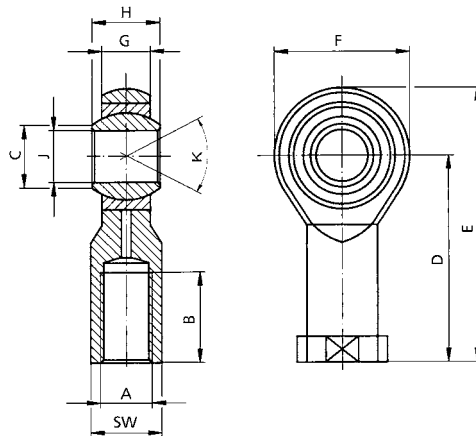

Dimensions (mm)

Piston Diameter	A	B	C	D	E	F	G	H	J	K	SW	Weight approx. (kg)	Order Code Steel
32	M10x1.25	20.0	13.0	43.0	57.0	28.0	10.5	14.0	10.0	8°	17	0.17	SC5/025
40	M12x1.25	22.0	15.5	50.0	66.0	32.0	12.0	16.0	12.0	8°	19	0.25	SC5/040
50/63	M16x1.5	28.0	19.5	64.0	85.0	42.0	15.0	21.0	16.0	8°	22	0.51	SC5/050
80/100	M20x1.5	33.0	24.5	77.0	102.0	50.0	18.0	25.0	20.0	8°	30	0.91	SC5/080

Material: galvanized steel

Conversions

kg X 2.205 = lbs.



Accessories/Mounting Parts

Alignment Coupler

for Cylinders with Piston Diameters 32 to 100 mm

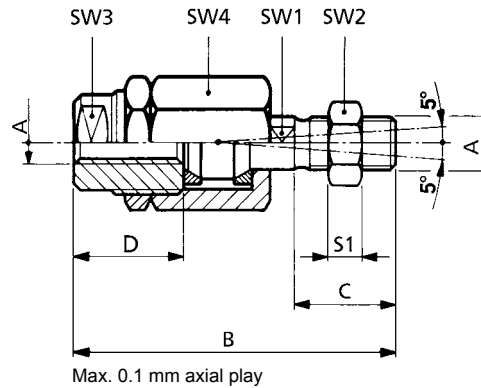

Dimensions (mm)

Piston Diameter	A	B	C	D	S1	SW1	SW2	SW3	SW4	Weight approx. (kg)	Order Code Steel
32	M10x1.25	72.0	20.0	26.0	6.0	12	17	19	30	0.210	SC16/032
40	M12x1.25	76.5	24.0	26.0	7.0	12	19	19	30	0.215	SC16/040
50/63	M16x1.5	108.0	32.0	34.0	8.0	19	24	30	42	0.650	SC16/050
80/100	M20x1.5	124.0	40.0	42.0	9.0	19	30	30	42	0.720	SC16/080

Material: galvanized steel

Conversions

kg X 2.205 = lbs.



Accessories/Switches and Sensors

Switches and Sensors

for Cylinders Profile Version with Magnetic and Proximity Switching and Locking Units

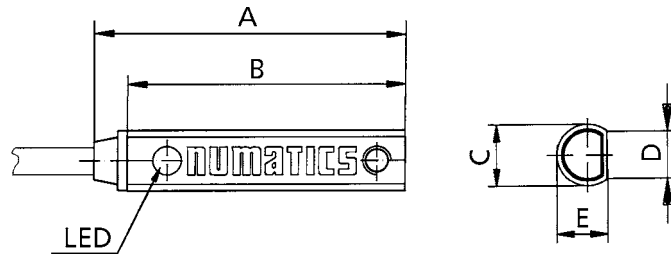

Dimensions (mm)

Reed Switch NO (normally open) (2-wire-version)	A	B	C	D	E	Weight approx. (kg)	Order Code
With 27-cm-cable made from PVC and M8x1 mm fem. conn. (Reed NO)	33.0	29.5	6.5	5.0	5.3	0.007	SRR-C02
With 2-m-cable made from PVC, 2x0.14 mm ² (Reed NO)	33.0	29.5	6.5	5.0	5.3	0.025	SRR-W20

Electronic Sensor NO (normally open) (3-wire-version)	A	B	C	D	E	Weight approx. (lb)	Order Code
With 27-cm-cable made from PVC and M8x1 mm fem. conn. (PNP NO)	33.0	29.5	6.5	5.0	5.3	0.007	SPR-C02
With 2-m-cable made from PVC, 3x0.14 mm ² (PNP NO)	33.0	29.5	6.5	5.0	5.3	0.025	SPR-W20
With 27-cm-cable made from PVC and M8x1 mm fem. conn. (NPN NO)	33.0	29.5	6.5	5.0	5.3	0.007	SNR-C02
With 2-m-cable made from PVC, 3x0.14 mm ² (NPN NO)	33.0	29.5	6.5	5.0	5.3	0.025	SNR-W20

Technical Data

	Reed Switch	Electronic Sensor	
	Reed NO	PNP NO	NPN NO
Operating voltage U_B	27-cm-cable 10-50 V AC/60 V DC 2-m-cable 10-120 V AC/DC	10-30 V DC	
Residual ripple U_{SS}	—	< 10% of U_B	
Voltage decrease U_d (at I_a max.)	≤ 3 V	≤ 2 V	
Current absorption (not activated)	—	≤ 10 mA	
Switching current I_a	< 100 mA	< 150 mA	
Response sensitivity	approx. 3 mT	approx. 3 mT	
EMV to	EN 60947-5-2	EN 60947-5-2	
Wire breakage protection	—	yes	
Short circuit protection	—	yes	
Reverse polarity protection	yes	yes	
Power-up pulse suppression	—	yes	
Protection to to DIN 40050	IP 67	IP 67	
Shock and vibration resistance	30 g, 11 ms, 10 to 55 Hz, 1 mm	30 g, 11 ms, 10 to 55 Hz,	
Ambient temperature T_a	-25 °C to +75 °C	-25 °C to +75 °C	
	Attention: • With DC-operation LED only illuminates when switch is correctly polarised! • Never operate sensor without load! • When switching higher capacitive and inductive loads, protection measures are to be taken!		

Conversions

$$(1.8^\circ \text{ } ^\circ\text{C}) + 32 = ^\circ\text{Fahrenheit}$$



Accessories/Switches and Sensors

Mounting of Switch/Sensor for Cylinders of Profile Version with Magnetic and Proximity Switching and for Locking Units



1. Insert switch/sensor into groove of cylinder or locking unit at any point



2. Turn switch/sensor by 90°.

3. Tighten screw M3
(key 1.5 mm is included)

Cords M8-thread for Switches and Sensors with Connector

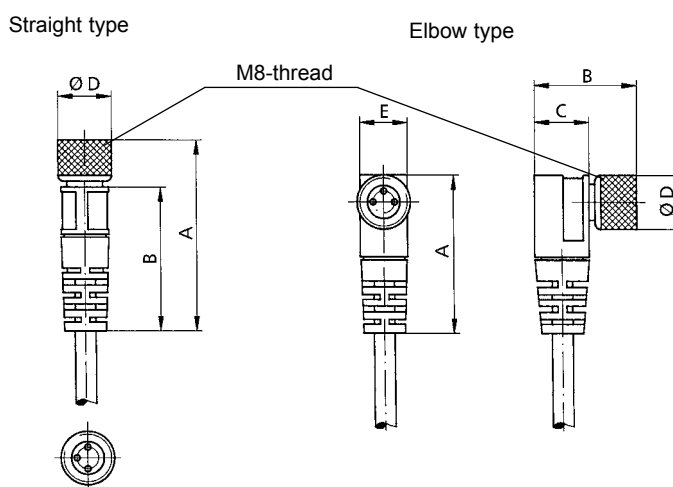

Dimensions (mm)

Type		A	B	C	D	E	Weight (approx. kg)	Order Code
Straight with 5m-cable	(3x0.25 mm ²)	32.3	24.4	—	9.0	—	0.143	SC6-001
Elbow with 5m-cable	(3x0.25 mm ²)	26.3	17.1	9.2	9.0	8.0	0.145	SC6-002



GeoMetric® VDMA 24562 / DIN/ISO 6431 / ISO 15552

Sensors for GeoMetric VDMA	Groove	Reed / Electronic	Wedging
Numatics			
SRR-xxx	Combi	Reed	ok
SPR-xxx	Combi	Electronic	ok
SNR-xxx	Combi	Electronic	ok
HNPQ32	Combi		
RSQ02	Combi		
CS 20 TN QD AdsensTech , Num USA	Ø4	Electronic	ok
AdsensTech	Ø4	Reed	ok
Festo			
SMT-8F-PS-24V-K0,3-M8D	Combi	Electronic	
SME-8F-DS-24V-K2,5-OE	Combi	Electronic	
SME-8-K-LED-230	Combi	Electronic	
SME-8-S-LED-24	Combi		ok
SME-8-SL-LED-24	Combi		NO
S8 13	Combi		
SMT-10-PS-KL-LED-24	Ø4	Electronic	ok
SME-10-SQ-LED-24	Ø4		ok
SME-10-SL-LED-24	Ø4		ok
SME-10F-DS-24V-K2,5L-OE	Ø4	Electronic	NO
Ultraline			
UL - 34R	Combi	Electronic	NO
new sensor without name	Combi	Reed	ok
35R	Combi	Reed	ok
35N	Combi	Electronic	ok
35P	Combi	Electronic	ok
Bosch			
0 830 100 488	Combi	Reed	NO
275 011 132			
Norgren			
M/50/EAP/CP	Combi	Electronic	ok
M/50/LSU/5V	Combi	Reed	ok
SMC			
D-Z 73L	Combi		ok
D-A 93	Ø4		ok
D-Y 7PL	Combi		ok
D-F9PL /	Ø4		ok
D-M9P	Ø4		ok
mPm			
DSL 1C	Combi	Reed	ok
DSL 4N	Combi	Electronic	ok
Balluff			
BMF 307 K-PS-C-S4	Ø4		ok
BMF 303 K -PS-C-2-49	Ø4		ok
BMF 103K-PS-C-2-S49	Ø4		ok
BMF 305 K - PS-C-2-S49	Combi		ok
HKL			
MKNO-5	Combi	Reed	ok
Gimatic			
SC4	Combi	Reed	ok
Pneumax			
1500.U		Reed	NO
Camozzi			
CST-220	Combi	Reed	ok
CSB-D-220	unknown	Reed	NO
Metal Work			
CR22M	Combi	Reed	NO



Technical Information

Force Table for Double Acting Cylinders
with Piston Diameters 32 to 100 mm

Piston Diameter (mm)	Piston Rod Diameter (mm)		Effective Piston Surface (cm ²)	Pressure (bar)								
				2	3	4	5	6	7	8	9	10
32	12	for thrust	8.0	141	212	282	353	424	494	565	636	706
		for tension	6.9	122	182	243	304	366	427	488	549	610
40	16	for thrust	12.6	223	334	445	555	667	780	893	1,001	1,109
		for tension	10.6	187	281	375	468	561	655	748	843	936
50	20	for thrust	19.6	346	520	692	865	1,040	1,207	1,383	1,560	1,727
		for tension	17.6	310	464	618	772	926	1,080	1,234	1,388	1,542
63	20	for thrust	31.2	551	827	1,099	1,373	1,648	1,933	2,207	2,482	2,757
		for tension	28.1	495	746	991	1,236	1,491	1,736	1,982	2,237	2,482
80	25	for thrust	50.3	889	1,334	1,776	2,217	2,668	3,110	3,551	4,002	4,444
		for tension	45.3	800	1,197	1,599	2,001	2,403	2,806	3,198	3,600	4,002
100	25	for thrust	78.5	1,383	2,080	2,776	3,463	4,159	4,856	5,543	6,239	6,926
		for tension	73.6	1,295	1,952	2,600	3,247	3,895	4,552	5,199	5,847	6,494

Friction losses are considered with 10%.

Table on Air Consumption for Double Acting Cylinders
with Piston Diameters 32 to 100 mm

Piston Diameter (mm)	Pressure (bar)								
	2	3	4	5	6	7	8	9	10
	Air Consumption (l) per 100 mm Stroke (uncompressed air)								
32	0.3	0.4	0.6	0.7	0.9	0.9	1.2	1.3	1.5
40	0.5	0.7	0.9	1.2	1.4	1.6	1.8	2.1	2.3
50	0.7	1.1	1.4	1.8	2.2	2.5	2.9	3.3	3.6
63	1.2	1.8	2.4	3.0	3.6	4.1	4.7	5.3	5.9
80	1.9	2.9	3.8	4.8	5.7	6.7	7.6	8.6	9.6
100	3.0	4.6	6.1	7.6	9.1	10.7	12.2	13.7	15.2

Value for a complete cycle

Conversions

Bars X 14.50 = psi

1 [N] newton = 0.22480894 [lbf] pound-force

Example: 1* .2248



Technical Information

Break-away Pressures for Double Acting Cylinders
with Piston Diameters 32 to 100 mm

Piston Diameter (mm)	Type GG (bar)
32	0.15-0.30 (0.70)
40	0.10-0.20 (0.60)
50	0.10-0.20 (0.60)
63	0.10-0.20 (0.40)
80	0.10-0.20 (0.40)
100	0.10-0.20 (0.40)

The values in brackets refer to a cylinder which has remained in its final position for a longer period of time (several hours or days). Due to long rest periods the material elastomer can “flow” into the rough walls of the cylinder barrel and it can “interlock”. For cylinders that are regularly in motion the first values without brackets are valid, as the “sticking effect” occurs only after a longer rest period.

Conversions

Bars X 14.50 = psi

NUMATICS

*World Class Supplier
of Pneumatic Components*

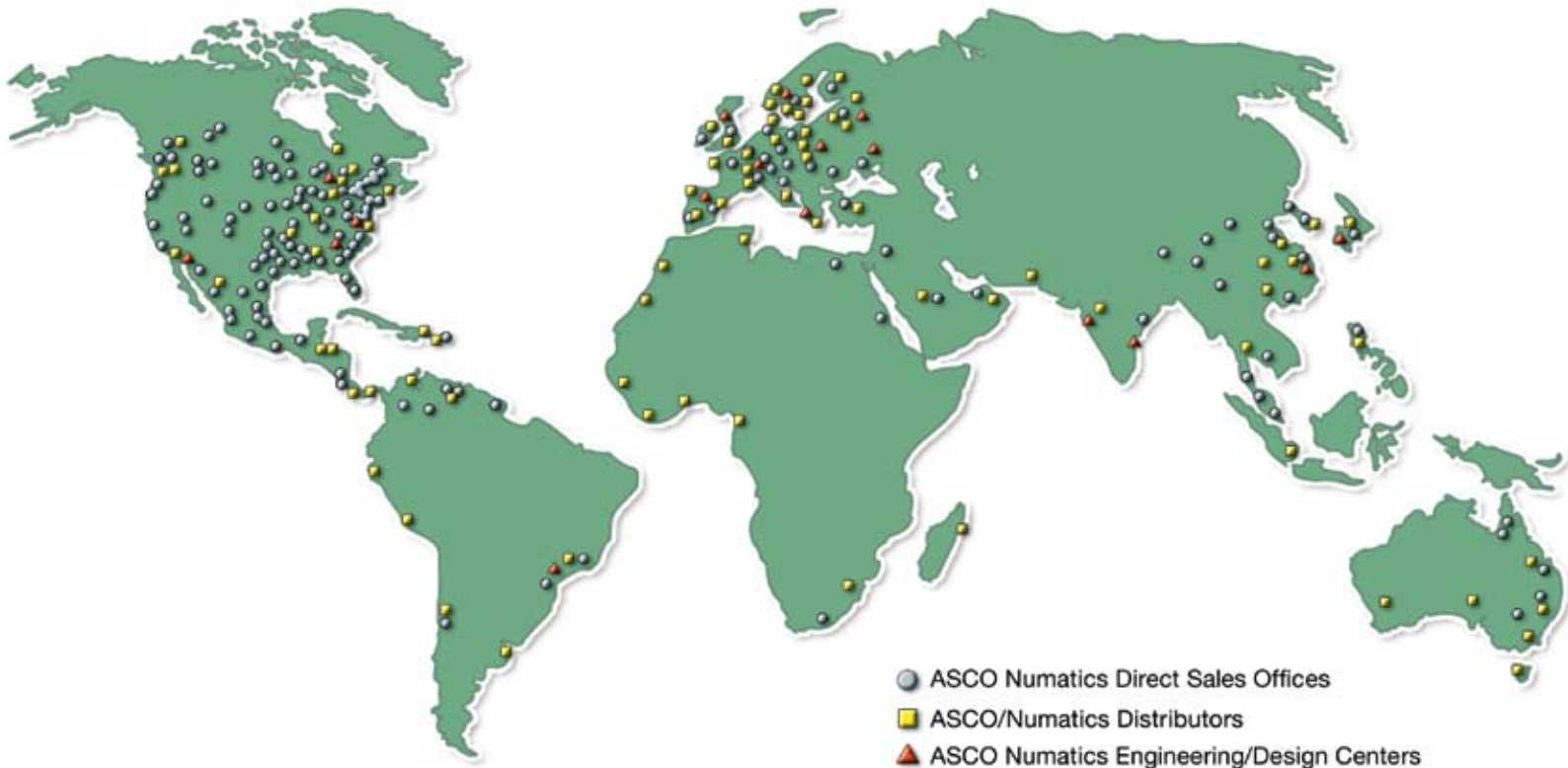

WORLD HEADQUARTERS

USA

Numatics, Incorporated

46280 Dylan Drive
Novi, Michigan 48377

P: 1-888-Numatics
1-888-686-2842

Canada

Numatics, Ltd

P: 519-452-1777

Mexico

Numatics de Mexico S.A. de C.V.

P: 52-222-284-6176

For a comprehensive listing of all Numatics production and distribution facilities worldwide, visit:

www.numatics.com