

# AOT 701-T/TH

## Table of Contents

1. Module Description .....	2
1.1 Analog Output Module AOT 701-T/TH .....	2
1.1.1 Dimensions .....	3
1.1.2 Terminal Assignment - Analog Outputs.....	3
1.1.3 Basic Circuit Diagram .....	4
1.1.4 Function Description .....	5
1.1.5 Behavior in the Event of Malfunctions .....	5
1.1.6 Technical Data.....	6

## List of Figures

Fig.01: Analog output module AOT 701-T/TH.....	2
Fig.02: Dimensions AOT 701-T/TH.....	3
Fig.03: Connection for variant 0...+10V.....	3
Fig.04: Connection for variant 0...+20mA.....	3
Fig.05: Basic circuit diagram .....	4
Fig.06: Galvanic separation of connections .....	7

# 1. Module Description

## 1.1 Analog Output Module AOT 701-T/TH

The AOT 701-T/TH output modules have 2 analog outputs with 10 bit resolution and signal ranges 0...+10 V / 0...+20 mA.

Module	Resolution	Article no.
AOT 701-T	10 bit	44120261
AOT 701-TH	10 bit	44120361

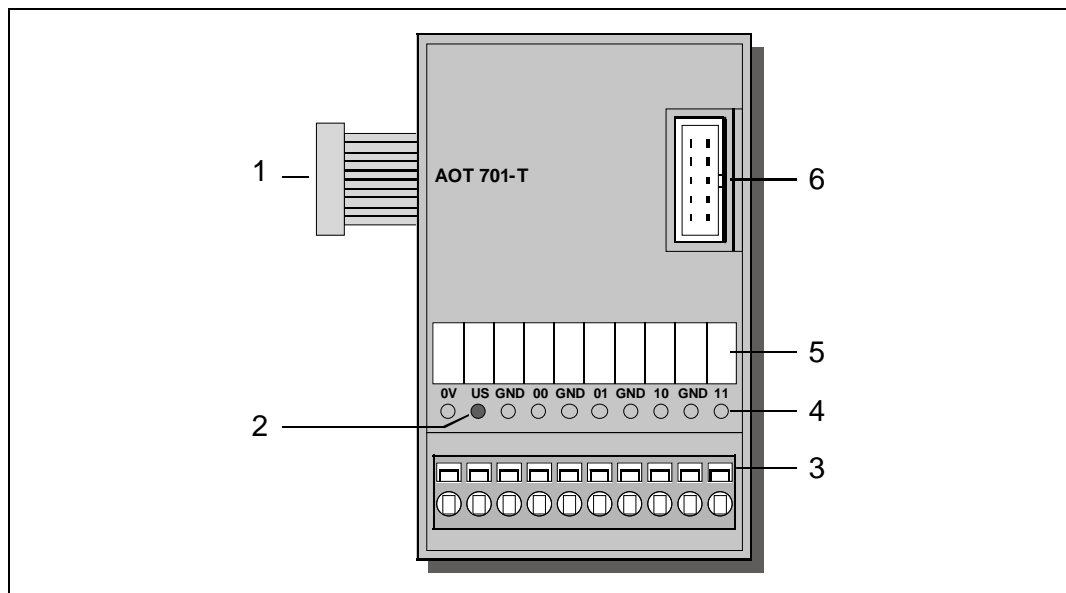

Fig.01: Analog output module AOT 701-T/TH

### Legend:

- 1: Link cable to previous module
- 2: ● LED indicator green (US)
- 3: Terminal strip for 2 outputs 0...10 V / 0...20 mA
- 4: LEDs: ● No LED function
- 5: Labeling strips
- 6: Link connector for extension modules

### 1.1.1 Dimensions

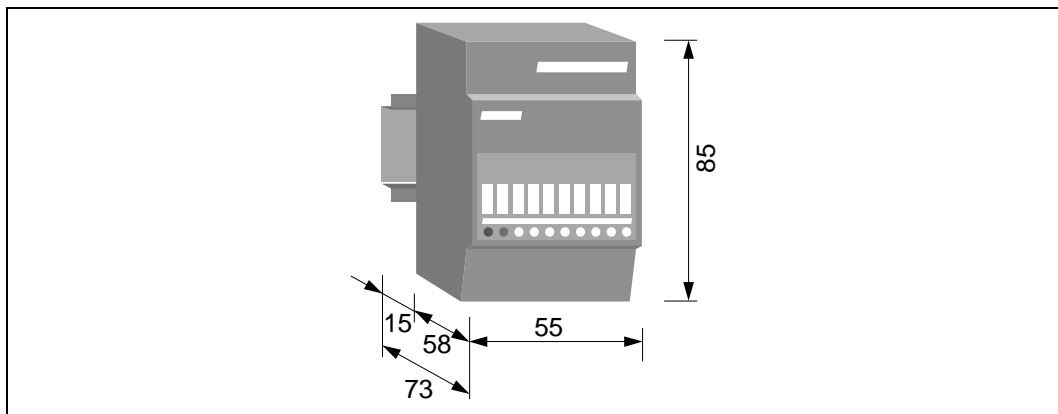

Fig.02: Dimensions AOT 701-T/TH

### 1.1.2 Terminal Assignment - Analog Outputs

The AOT 701-T/TH module is wired to a 10-pole terminal block:

**Analog outputs 0...3:**

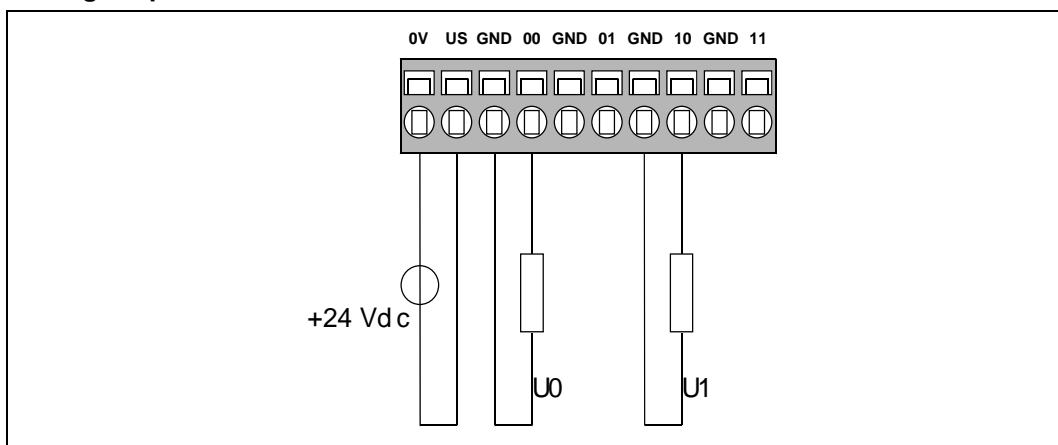

Fig.03: Connection for variant 0...+10V

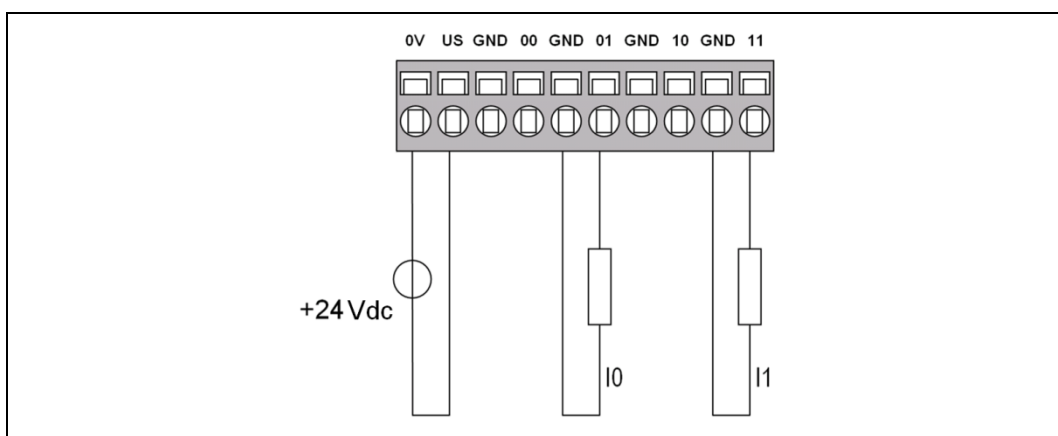

Fig.04: Connection for variant 0...+20mA

### 1.1.3 Basic Circuit Diagram

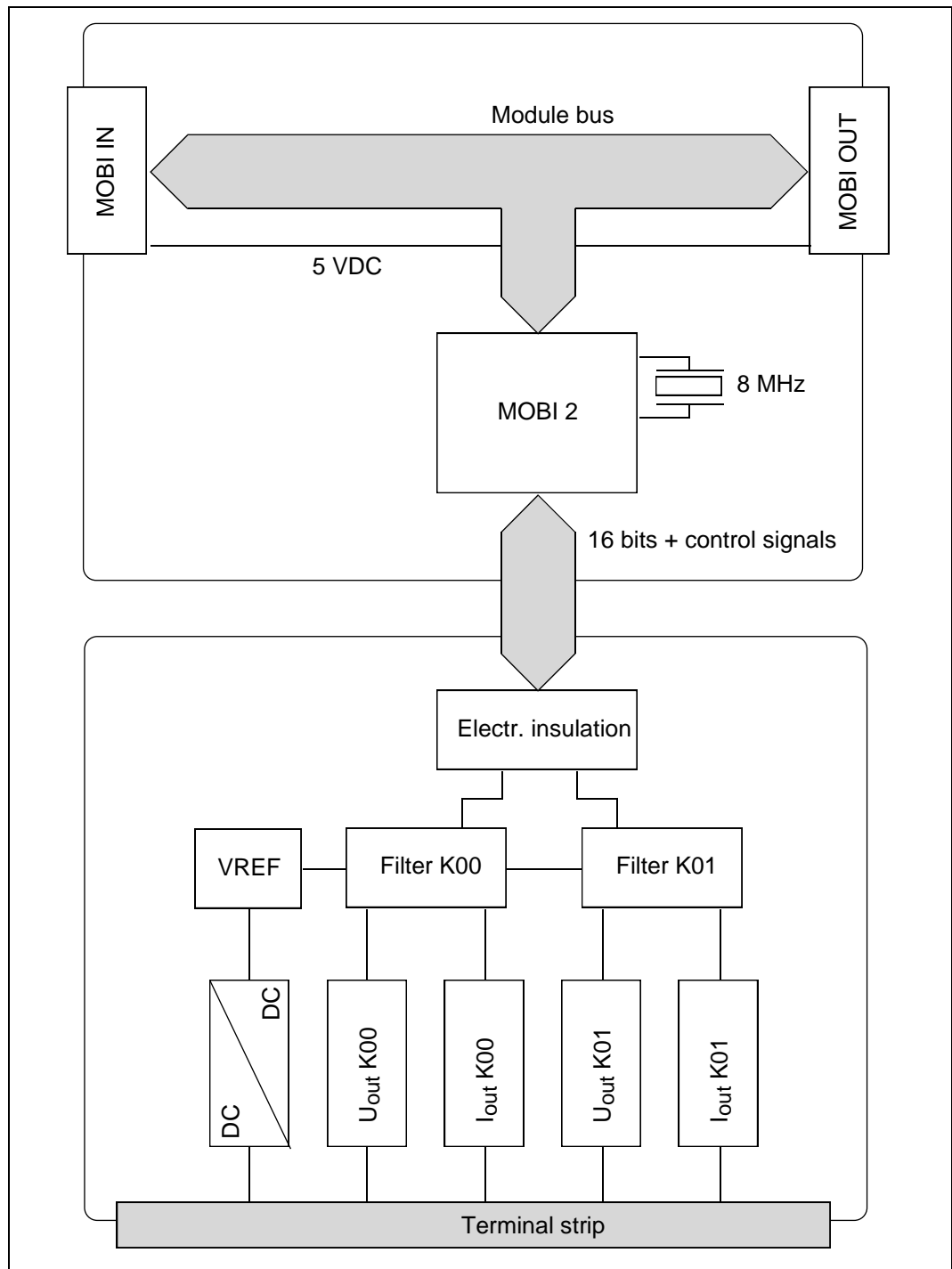

Fig.05: Basic circuit diagram

## 1.1.4 Function Description

The module has 2 analog outputs with 10 bit resolution. The output signal is generated with a PWM signal which reaches an impedance converter via a 3-level RC filter. The signal is then amplified and transmitted to the voltage, respectively current, output level. This eliminates any switching between current and voltage output. The module is supplied externally (US) by means of a plug-in terminal.

## 1.1.5 Behavior in the Event of Malfunctions

### Short Circuit of the Voltage Outputs

The voltage outputs are short-circuit-proof. Thus, a correct output voltage is no longer possible. A short-circuit is not detected.

### Load Resistance too High at the Current Outputs

The output voltage rises to the supply voltage. A correct output current is no longer possible. This error is not detected.

### Supply Voltage - US

If the external US supply falls below a defined limit, a POWER FAIL message is generated.

Limits on AOT 701-T: 16.8 V

Limits on AOT 701-TH: 18.0 V

### Return Supply

A return supply of up to a maximum of 30 V does not lead to destruction.

## 1.1.6 Technical Data

Technical Data	AOT 701-T	AOT 701-TH
Overall failure rate	$\lambda = 747 \text{ FIT}^{1)}$	
Number of outputs (voltage/current)	2	
Supply voltage US	24 Vdc	36 Vdc
Limits	16.8...30.0 Vdc	25.2...45.0 Vdc
Max. power consumption US	2000 mW	
Max. logic consumption	$\leq 180 \text{ mW}$	
Signal ranges	0...10 V / 0...20 mA	
Digital resolution	10 bit	
Value per increment	9.77 mV / 19.55 $\mu\text{A}$	
Total conversion time/channel	512 $\mu\text{s}$	
Transient time (90 %)	7 ms	
Maximum error at 25 °C		
0...10 V	$\pm 0.4 \%$ (scale end value)	
0...20 mA	$\pm 0.5 \%$ (scale end value)	
Maximum error at range		
0...+55 °C	$\pm 0.6 \%$ (scale end value)	
-25...+70 °C	$\pm 0.7 \%$ (scale end value)	
Non-linearity over the whole range	$\pm 0.2 \%$	
Load resistance		
Voltage output U	$> 2 \text{ k}\Omega$	
Current output I	$< 300 \Omega$	
Conversion principle	PWM signal with filter	
Type of protective switching	Metal oxide varistors (MOV)	
Ambient temperatures		
Operation	-25...+70 °C	
Storage	-40...+85 °C	
Inserting/removing the module bus while supply voltage UC is applied to the node modules	Removing permitted, Inserting not permitted	
Index of protection	IP40	
Weight	120 g	
Dimensions (WxHxD)	55 x 85 x 58 mm	
Article no.	44120261	44120361

$$1) \lambda: \text{Overall failure rate} \quad \left| \quad \text{MTBF} = \frac{10^9}{\lambda[\text{FIT}]} ; \lambda[\text{FIT}] = \frac{10^9}{\text{MTBF}} \right.$$



### Note

Selectron checks its modules according to the criteria listed in the "[System Manual MAS 72x](#)", chapter "Standards and Test Regulations".

## Galvanic Separation

The interfaces are isolated from each other according to the following principle:

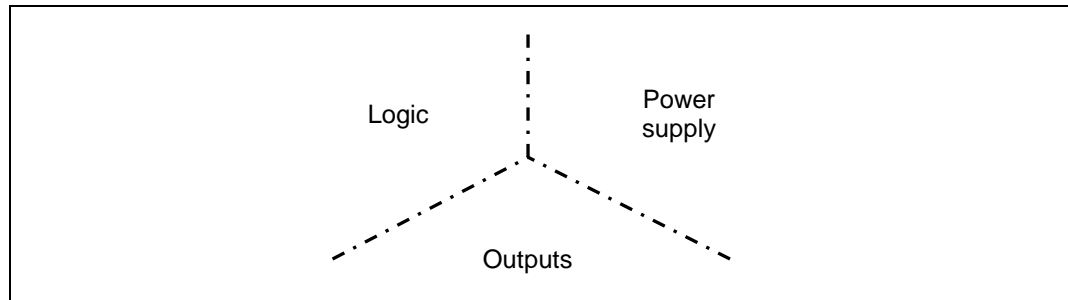

Fig.06: Galvanic separation of connections

### **!** IMPORTANT

The outputs are not electrically isolated among each other.

## EMC Protection Circuitry between Power Supply and Earth

Detailed information regarding the EMC protection circuitry between power supply and earth connection is contained in the "[System Manual MAS 72x](#)", chapter "Installation, Startup, and Operation", [2.4 EMC Protection Circuitry between Power Supply and Earth Connection](#).