

GE11-12-13

OIL Lubrication Groups

Single line system

142.200.000

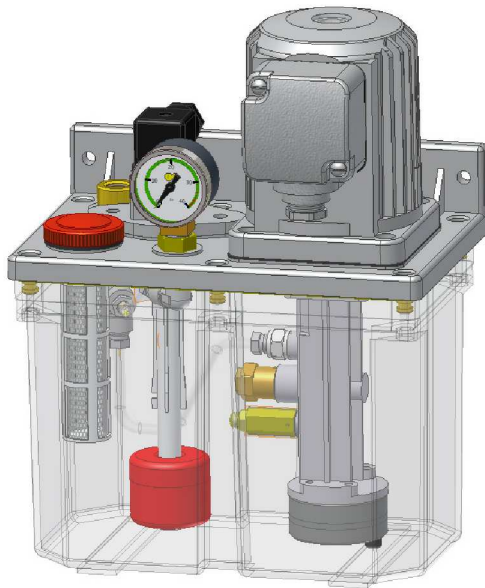

Application

As an intermittent operation unit to feed volumetric dosing meters in single-line systems.

The basic execution includes a motor/gear pump unit, as well as the necessary valves to control the pressure and decompression cycles in the circuit.

Operation

The working control of these units is external (without control): programming by means of the machine automatism or external control (cnc, automatic device, etc...).

It can be equipped with an electrical level (minimum level control in the tank).

Technical characteristics

Gear pump

Lubricant Mineral or synthetic oils
 Viscosity 30 ÷ 1500 cSt
 Flow 0,2-0,5 l/min
 Working pressure 30 bar
 Working temperature +10°C ÷ +40°C

Electric motor

Voltage.....	230/400V	24VDC
Frequency.....	50/60Hz	
Power.....	100W (50Hz)	55W
Consumption.....	0,5A (50Hz)	2,5A
rpm.....	2800 (50Hz)	2800

Service mode..... S3 20%*
 Maximum operation time..... 5 min
 Máximo cycles/hour..... 20

*Ratio between the operation time and the stop time: 1 min of operation time corresponds to 5 min stop time.

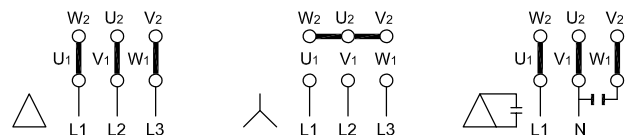

Hydraulic diagram

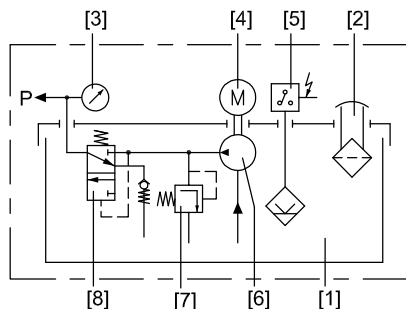

- 1-Tank
- 2- Filling cap - Filter
- 3- Pressure gauge
- 4- Electric motor
- 5- Level switch
- 6- Gear pump
- 7- Pressure limiting valve
- 8- Relief valve
- P = Pressure outlet

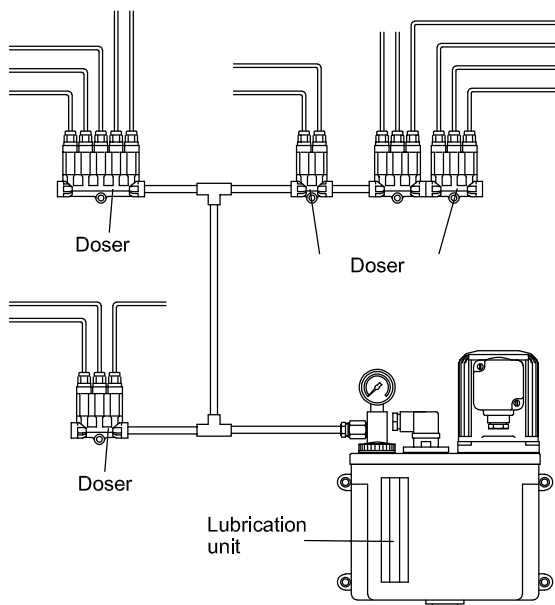

CAUTION!!!

THE FOLLOWING SAFETY MEASURES MUST BE TAKEN: DISCONNECT THE MAIN SWITCH BEFORE CARRYING OUT CONNECTION COUPLING.

Electric level switch

Type of contact Reed
 Maximum switching voltage..... 230 VUC
 Maximum switching consumption..... max. 0,5 A
 Power breakdown max. 30 W
 Connector..... DIN EN 175301-803
 Function see diagram

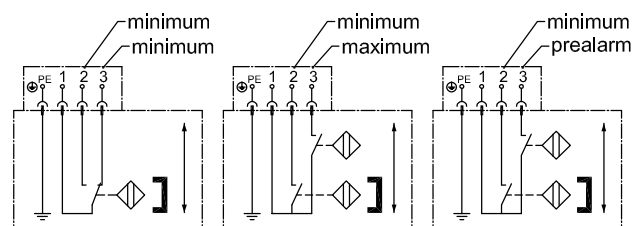

Lubrication group for oil
 Single line system

GE11/B
 3L plastic
 142.000.000

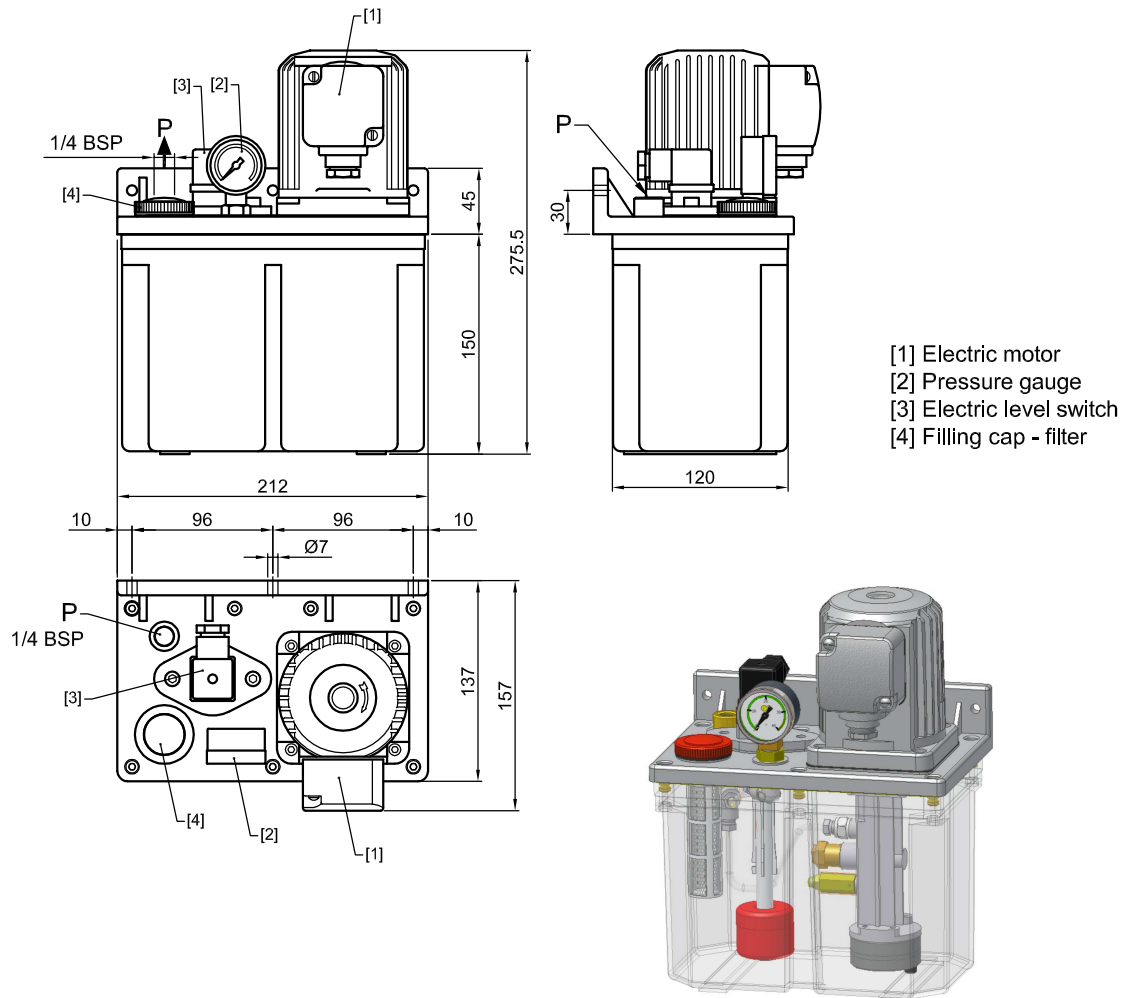

GE11/**X**-1-**X X X**

Tank capacity	Flow l/min	Monitoring system		Voltage
(B) 3 litres	(2) 0,2 (5) 0,5	(0)	Without level	(0) 24Vdc (3) 230/400V 50/60Hz
		(5)	Minimum level	
		(6)	Maximum - minimum level	
		(7)	Minimum + prealarm level	

Lubrication group for oil
 Single line system

GE11/C
 6L plastic
 142.005.000

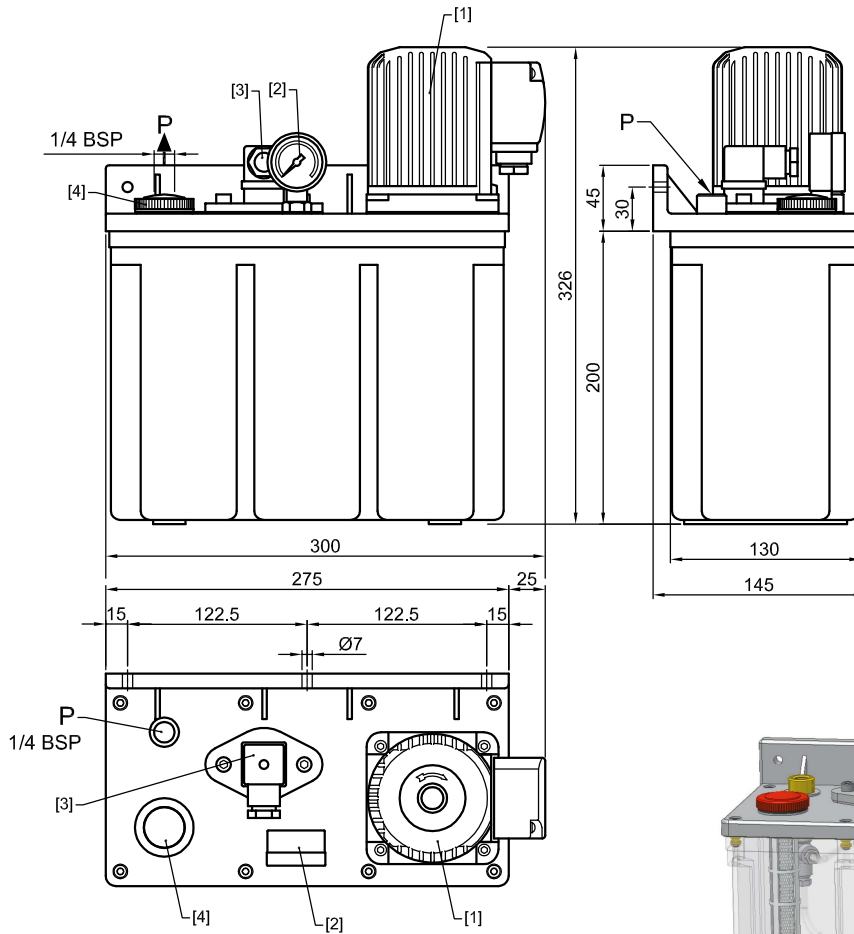

- [1] Electric motor
- [2] Pressure gauge
- [3] Electric level switch
- [4] Filling cap - filter

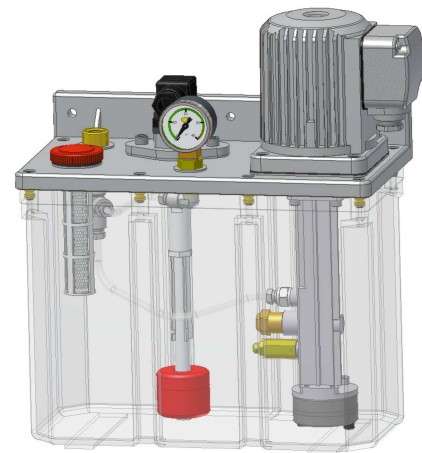

GE11/ (X) - 1 - (X) (X) (X)

Tank capacity	Flow l/min	Monitoring system		Voltage
(C) 6 litres	(2) 0,2 (5) 0,5	(0)	Without level	(0) 24Vdc
		(5)	Minimum level	
		(6)	Maximum - minimum level	(3) 230/400V 50/60Hz
		(7)	Minimum + prealarm level	

Lubrication group for oil
 Single line system

GE12/B
 3L aluminium
 142.400.000

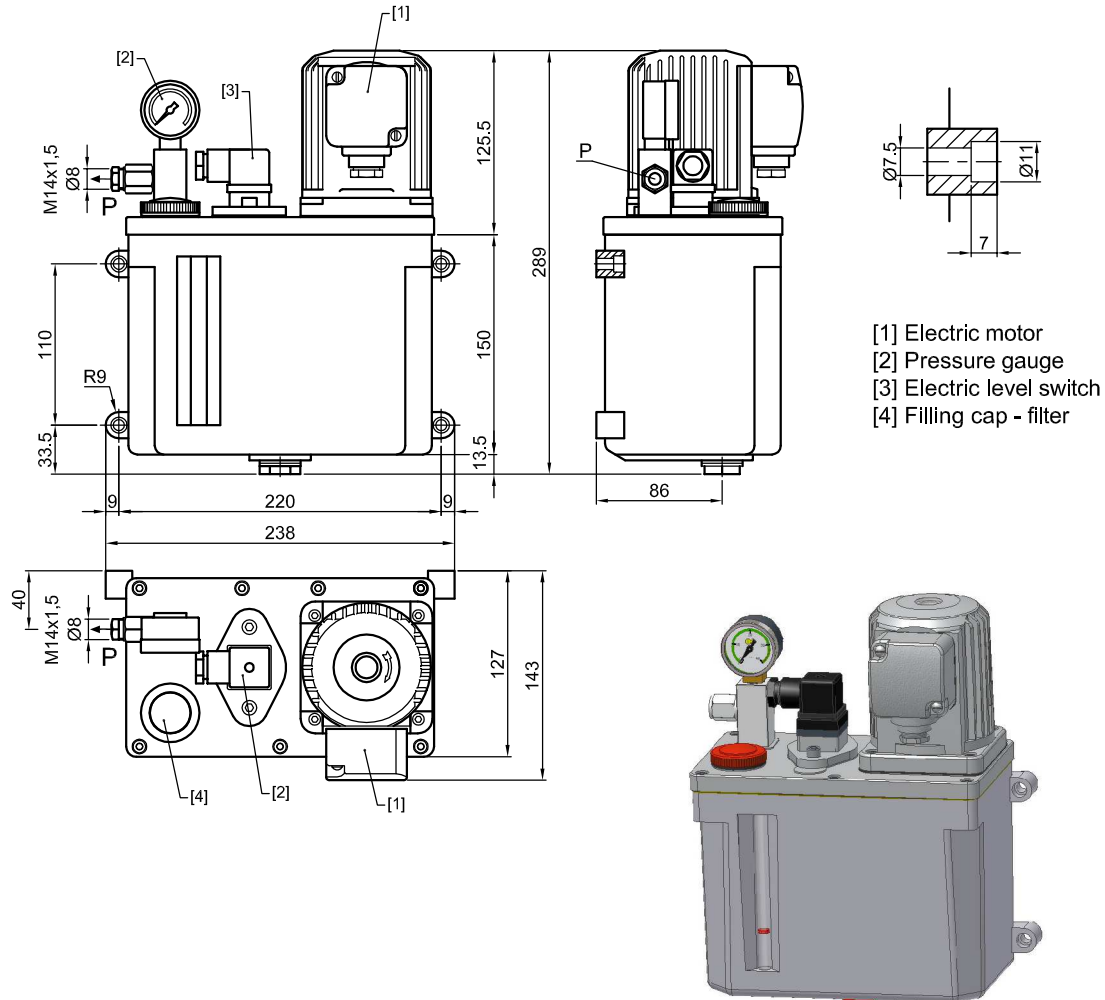

GE12/**X**-1-**X X X**

Tank capacity	Flow l/min	Monitoring system		Voltage
(B) 3 litres	(2) 0,2 (5) 0,5	(0)	Without level	(0) 24Vdc
		(5)	Minimum level	
		(6)	Maximum - minimum level	(3) 230/400V 50/60Hz
		(7)	Minimum + Prealarm level	

Lubrication group for oil
 Single line system

GE13/C 6L metal
GE13/D 10L metal
 142.500.000

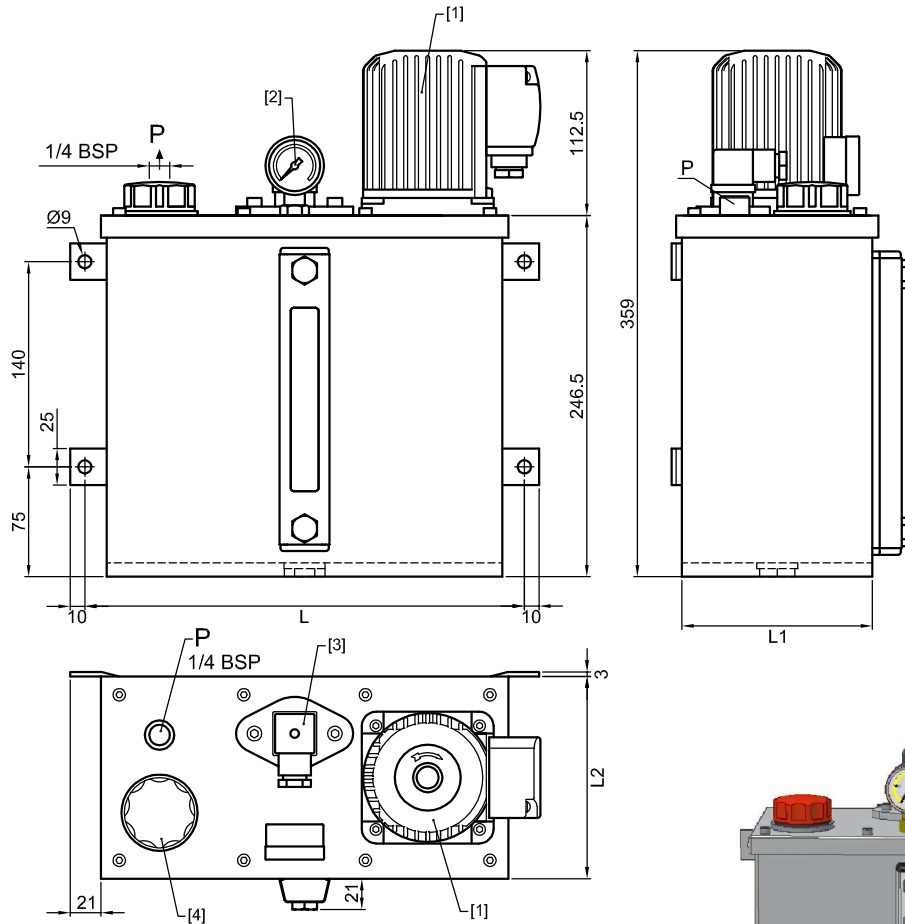

- [1] Electric motor
- [2] Pressure gauge
- [3] Electric level switch
- [4] Filling cap - filter

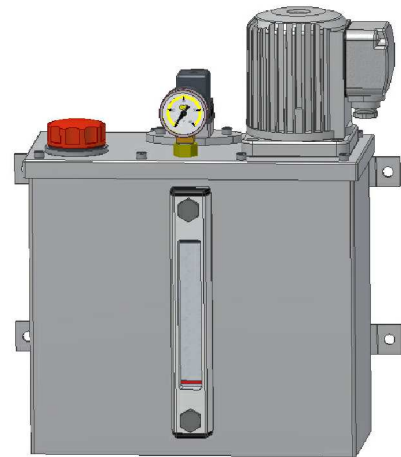

Capacity	L	L1	L2
6 litres	300	130	138
10 litres	405	155	163

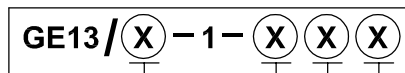

Tank capacity	Flow l/min	Monitoring system	Voltage
(C) 6 litres	(2) 0,2	(0) Without level	(0) 24Vdc
(D) 10 litres	(5) 0,5	(5) Minimum level	(3) 230/400V 50/60Hz
		(6) Maximum - minimum level	
		(7) Minimum + prealarm level	