

Technical manual

Sylax butterfly valves - DN 25-350 mm

sylax^x

Summary



• Sale leaflet	p.2
• Spare parts list	p.3
• Overall dimensions	p.4-5
• Top connections of the actuators	p.6
• Actuators	p.7
• Connecting flanges	p.8-9
• Normalisation	p.10
• Pressure	p.11
• Torque values - Pressure/Temperature diagram	p.12
• Flow rate (Kv)Δ	p.13
• Head loss chart (Δp)	p.14
• Type of flange	p.15
• Tag/Traceability	p.15
• Bolts and nuts	p.16-17
• Bolts and nuts	p.18
• Installation	p.19

Applications and main characteristics

Industrial processes and general services

Applications :

- Water distribution and supply with the main European approvals, water treatment, most of the fluids of general services.
- Industrial applications such as :
Metallurgical, mining, paper-making, shipbuilding, nuclear, environmental and mechanical, food industry (see our list of approvals).
- For special applications, especially for particularly difficult media, contact our technical back office team.

Main characteristics :

- Multiple connections : centering lugs, tapped lugs, central and double flange.
- Vertical and horizontal operating position.
- High power transmission with robust grooved connection between the shaft and the disc.
- Easy maintenance by removing the circlips
- Interchangeable disc and liner.
- Body in cast iron GJL1040, ductile iron GJS1030 , steel and stainless steel.
- Body epoxy coated 80μm colour blue RAL 5017 (a lot of other coatings on option, please ask our sales department)
- Wide choice of actuators.

An **mounting instruction** specifying the installation characteristics and the commission of the Sylax 25-350 mm is added to every product when the ATEX version is specified; It is available on our web site www.socla.com or on request by our sales department.

Sale leaflet

By concentrating the technologies and by integrating technical solutions of the highest levels, Socla fulfils its ambition :

- competitiveness of a standard range,
- reliability,
- comprehensive range thanks to a multiplicity of solutions.

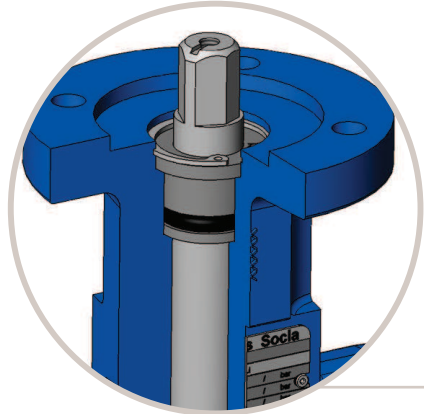

- Safety anti-ejection circlip keeps shaft in place and allows easy maintenance
- Safety reinforced by a secondary water-tightness.
- Spline driven one piece shaft connected to floating disc :

.high reliability of tightness and torque transmission in the long term.

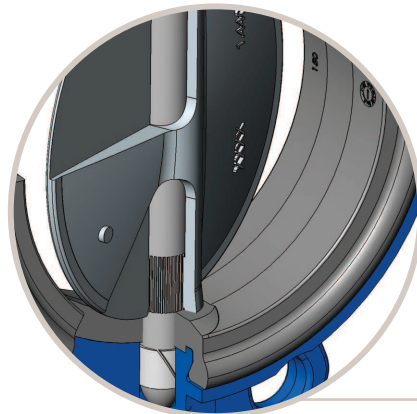

- High power transmission with robust grooved connection between the shaft and the disc.
- Complete protection of the shaft and valve body from fluids.
- Reliability of movements with self-lubricating bearings.

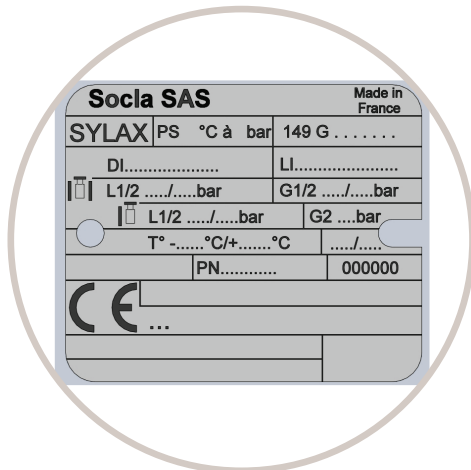

- Identification and traceability ensured by riveted metal tag : see on page 15.

Spare parts list

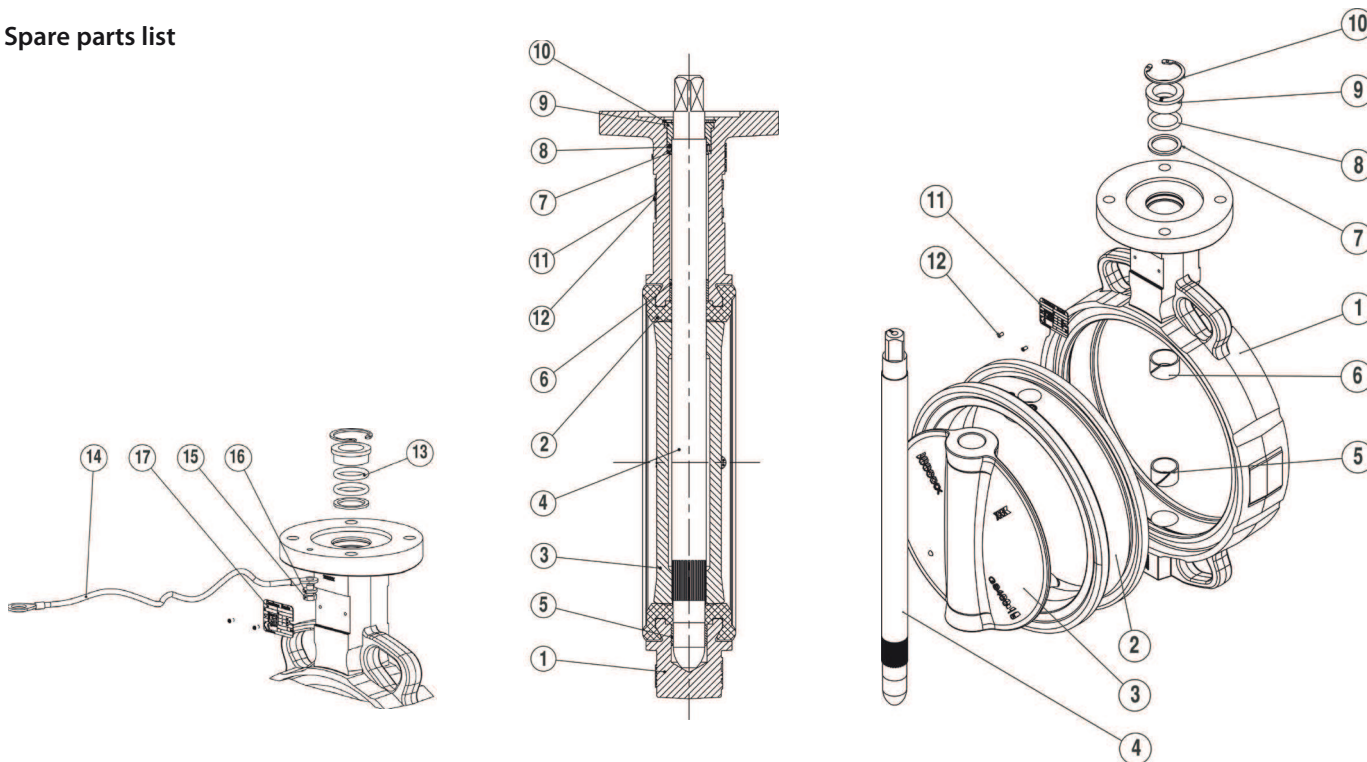

Nb	DESCRIPTION	Qty	MATERIALS ACCORDING TO NORMS			
			Materials	EN	ASTM	JIS
1	Body	1	Ductile iron	EN GJS 400-15 (JS 1030)	-	FCD40
			Cast iron	EN GJL 250 (JL 1040)	-	FC25
			Steel	GE 280 (E280 - 480M)	gr WCB	-
			Stainless steel	GX5 CrNiMo 19-11-2 (1.4408)	316	SUS 316
2	Liner	1	EPDM	-	-	-
			White EPDM	-	-	-
			High content nitrile	-	-	-
			White nitrile	-	-	-
			Carboxylated nitrile	-	-	-
			CSM (Polyethylen chloro-sulfonated)	-	-	-
			Silicone	-	-	-
			FKM	-	-	-
			Buthyl	-	-	-
3	Disc	1	Ductile iron	EN GJS 400-15 (JS 1030)	-	FCD40
			Stainless steel	GX5 CrNiMo 19-11-2 (1.4408)	316	SUS 316
			Stainless steel	X2 CrNiMo 17-12-2 (1.4404)	316L	SUS 316L
			Alu-bronze	CuAl10Fe5Ni5 (CC333G)	-	-
			Alu-bronze Annealing with protective gas/Epoxy	CuAl10Fe5Ni5 (CC333G)	-	-
4	Stem	1	Stainless steel	X5 CrNiCuNb 16-4 (1.4542)	630	SUS 630
			Stainless steel	X2 CrNiMo 17-12-2 (1.4404)	316L	SUS 316L
			Stainless steel	X30 Cr13 (1.4028)	420	SUS 420 J2
5 - 6	Anti-friction bearing	1	Zinc coated steel + PTFE	-	-	-
7	Anti-extrusion bush	1	Stainless steel	X5 CrNi 18-10 (1.4301)	304	SUS 304
			Plastic	IXEF 50 FV	-	-
8	O-ring	1	Nitrile/FKM	-	-	-
9	Sealing washer	1	Plastic	IXEF 50 FV	-	-
			Stainless steel	X5 CrNi 18-10 (1.4301)	304	SUS 304
			Brass	CuZn39Pb2 (CW612N)	-	-
10	Circlips	1	Stainless steel	X30 Cr13 (1.4028)	420	SUS 420 J2
			Steel	XC 75	-	-
11	Identification plate	1	Aluminium	EN AW - AL995 (EN AW - 1050A)	-	-
12	Rivet	2	Alu / Stainless steel	-	-	-

ATEX special spare parts list

13	Braid	1	Tinned copper	-	-	-
14	Discharge electro-static braid	1	Tinned copper	-	-	-
15	Screw	1	Stainless steel	A2 - 70	304	SUS 304
16	Stop washer	1	Stainless steel	X5 CrNi 18-10 (1.4301)	304	SUS 304
17	ATEX identification plate	1	Aluminium	EN AW - AL995 (EN AW - 1050A)	-	-

Overall dimensions

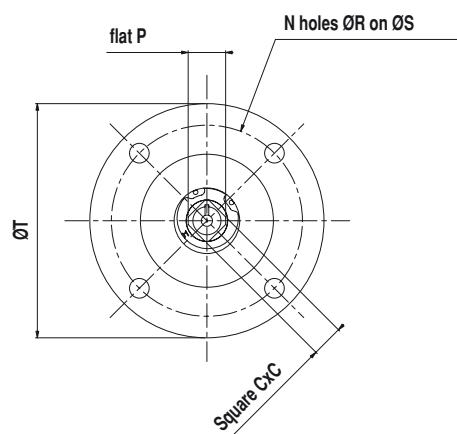
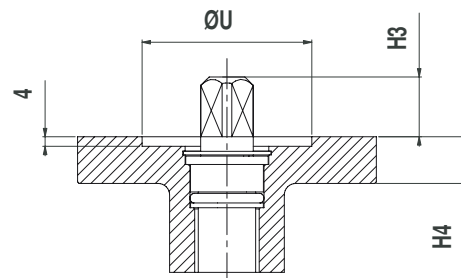
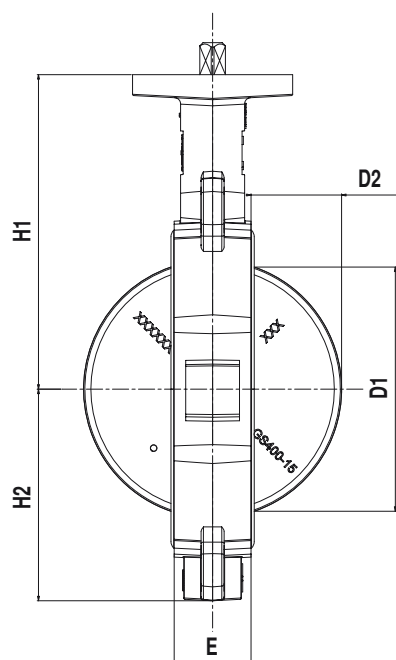

• 4 Centring lugs

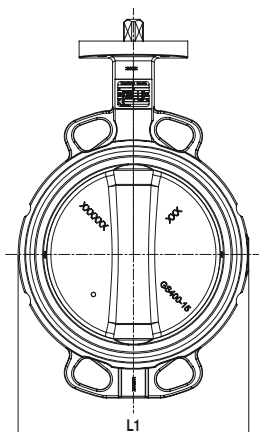

Diameter		Face to face	Overall dimensions				Iso top according to ISO 5211					Square drive outlet			Travel of the disc		Weight Kg		
DN	NPS	E	L1	H1	H2	H4	N	Ø R	Ø S	Ø T	Ø U	N°	□C	H3	Flat P	D1	D2	(1)	(2)
25	1	32	100	125	50	12	4	6,5	50	65	36	F05	11	16	11	6	1	-	1,6
32/40	1 1/2	32	144	130	57	12	4	6,5	50	65	36	F05	11	16	11	31	6,5	1,9	1,7
50	2	43	121	136	62	12	4	6,5	50	65	36	F05	11	16	11	29	4,5	2,5	2,5
65	2 1/2	46	136	145	70	12	4	6,5	50	65	36	F05	11	16	11	48	10	2,7	2,9
80	3	46	127	151	89	12	4	6,5	50	65	36	F05	11	16	11	67	18	2,8	3,2
100	4	52	153	175	106	12	4	8,5	70	90	56	F07	14	19	14	88	25	4,9	5,2
125	5	56	182	190	120	12	4	8,5	70	90	56	F07	14	19	14	113	35	6,2	6,3
150	6	56	209	203	131	12	4	8,5	70	90	56	F07	14	19	14	141	48	7,1	7,3
200	8	60	265	245,5	164	15,5	4	10,5	102	125	71	F10	17	24	20	192	71	15,4	13,7
250	10	68	317	271	200	16	4	10,5	102	125	71	F10	22	24	26	242	91,5	19	20,1
300	12	78	370	296	235	16	4	12,5	125	150	87	F12	22	29	26	291	112	30,2	29,2
350	14	78	424	305	270	16	4	12,5	125	150	87	F12	27	29	-	331	132	35,9	36,2

(1) Ductile iron body (J51030), ductile iron disc (J51030), EPDM liner.
 (2) Cast iron body (JL1040), ductile iron disc (J51030), EPDM liner.

• 2 Centring lugs

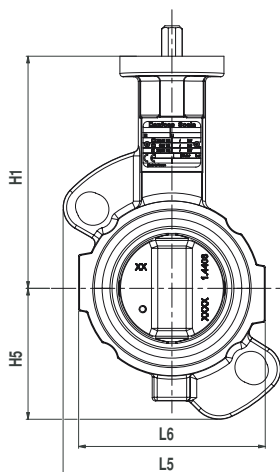

Diameter		Face to face	Overall dimensions				Iso top according to ISO 5211					Square shaft outlet			Travel of the disc		Weight Kg			
DN	NPS	E	L5	L6	H1	H5	H4	N	Ø R	Ø S	Ø T	Ø U	N°	□C	H3	Flat P	D1	D2	(1)	(2)
32/40	1 1/2	32	106	99	130	56	12	4	6,5	50	65	36	F05	11	16	11	31	6,5	1,7	1,6
50	2	43	121	99	136	73	12	4	6,5	50	65	36	F05	11	16	11	29	4,5	2,6	2,1
65	2 1/2	46	136	117	145	82	12	4	6,5	50	65	36	F05	11	16	11	48	10	3,1	2,4
80	3	46	150	136	151	93	12	4	6,5	50	65	36	F05	11	16	11	67	18	3,2	2,8
100	4	52	166	167	175	106	12	4	8,5	70	90	56	F07	14	19	14	88	25	5,3	4,4
125	5	56	132	194	190	127	12	4	8,5	70	90	56	F07	14	19	14	113	35	6,6	5,7
150	6	56	139	225	203	147	12	4	8,5	70	90	56	F07	14	19	14	141	48	8,1	6,8
200	8	60	164	279	245,5	174	15,5	4	10,5	102	125	71	F10	17	24	20	192	71	13,5	12,1
250	10	68	187	332	271	210	16	4	10,5	102	125	71	F10	22	24	26	242	91,5	20,5	18,1
300	12	78	166	382	296	239	16	4	12,5	125	150	87	F12	22	29	26	291	112	29,2	26
350	14	78	185	435	305	267	16	4	12,5	125	150	87	F12	27	29	-	331	132	37,5	-

(1) Stainless steel body (1.4408), stainless steel disc (1.4408), EPDM liner.
 (2) Steel body (WCB), stainless steel disc (1.4408), EPDM liner.

Torque values

Wet torques (Nm)		25	32	40	50	65	80	100	125	150	200	250	300	350
		PS6	EPDM	10	10	10	10	15	20	35	65	83	100	200
	NBR	10	15	15	18	23	30	50	93	115	150	255	380	560
PS16	EPDM	10	15	15	18	30	32	50	83	115	180	280	430	500
	NBR	10	15	15	24	35	40	66	100	155	220	340	500	720
PS20			20	20	32	45	65	100	130	190	350	560	850	1250
PS25			25	25	50	70	120	240	270	460				

NOTE :

Torques for liner in EPDM and High Content Nitrile (except DN250 to 350 for PS20).
One actuation minimum per month.

Pressure/temperature diagram

EPDM liner DN 25 up to 350

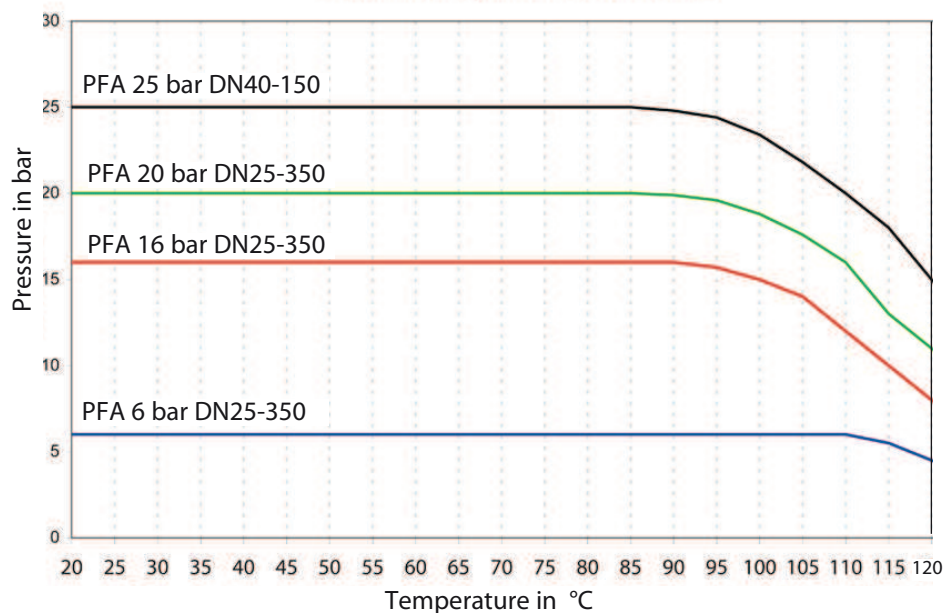

For every other elastomer, please ask our sales department.

Flow rate (Kv)

OPENING STAGE - Stainless steel disc

DN	10°	20°	30°	40°	50°	60°	70°	80°	90°
25	-	-	-	3	8	16	27	35	40
32/40	-	-	-	5	12	25	40	56	62
50	-	-	1	8	18	33	54	71	79
65	-	-	6	19	41	76	118	158	174
80	-	3	18	43	79	138	211	252	275
100	-	15	38	83	154	253	368	458	496
125	-	20	61	134	249	399	599	792	883
150	5	37	100	200	374	600	863	1109	1212
200	15	76	200	399	680	1099	1666	2196	2500
250	40	150	333	621	1084	1765	2652	3517	3948
300	60	219	500	989	1736	2770	4097	5118	5635
350	145	420	882	1676	2850	4462	6000	7431	8520

The butterfly valve is not the best product for regulating. Nevertheless, the Sylax 25-350 mm butterfly valve can be used to regulate by an opening stage between 30° and 90°.

A regulation in the opening stage lower than 30° is not advisable because of over speed, cavitation effect, which could damage prematurely the valve.

Kv = volume of water in m³/h through a valve at a preset opening stage and under a head loss of 1 bar.

The maximum flow velocity of the fluid through the valve must not exceed :

- 3 m/s for liquid fluids. Between 3 and 5m/s, the use of the Sylax 25-350 mm butterfly valve is possible, but the phenomena of cavitation, noise, vibration and water hammering increase.
- 20m/s for gas. Between 20 and 25m/s, the use of the Sylax 25-350 mm butterfly valve is possible, but the phenomena of cavitation, noise, vibration and water hammering increase.
- for pulverulent or paste fluids : please consult us.

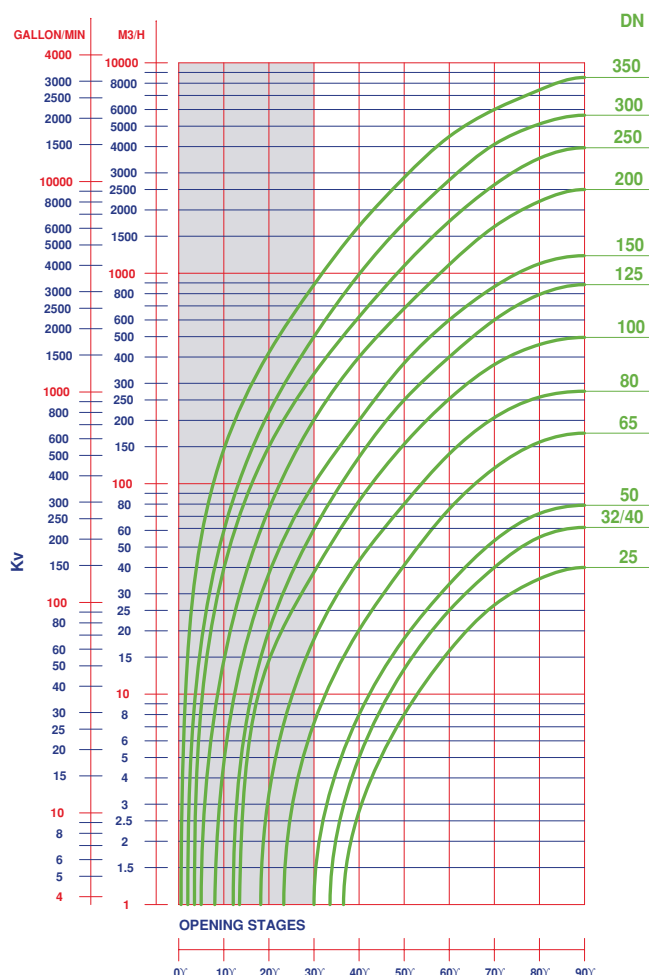

Type of flange

The Sylax 25-350 mm butterfly valve has been designed to be mounted on normalised standard flanges. Only standard flanges type 11, 21 and 34 according to EN 1092 are quite compatible.

For other types of flanges, refer to the table below. Non appropriate connections will cancel our guarantee.

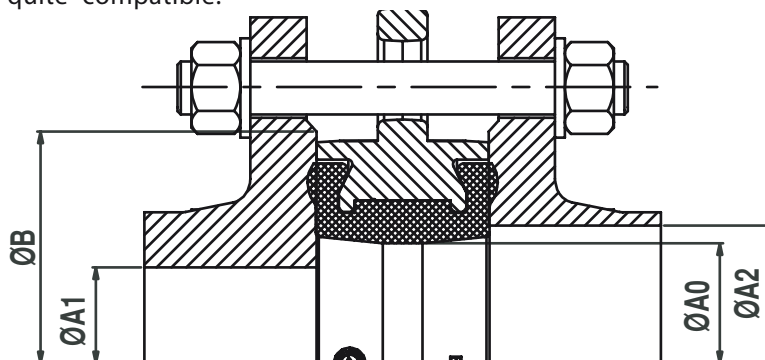

DN		Ø A0	Ø A1 mini	Ø A2 maxi	Ø B mini
25	1	32	-	44	60
32	1 1/4	43	33	51	80
40	1 1/2	43	33	51	80
50	2	50	36	59	90
65	2 1/2	65	54	74	110
80	3	80	73	88	128
100	4	100	93	116	148
125	5	125	119	143	178
150	6	150	146	166	202
200	8	200	196	224	258
250	10	250	246	280	312
300	12	300	296	329	365
350	14	340	335	369	415

NOTE :
The use of expansion seals, as well as the use of elastomer coated flanges, between the flange and the valve are strictly forbidden.

Tag / traceability

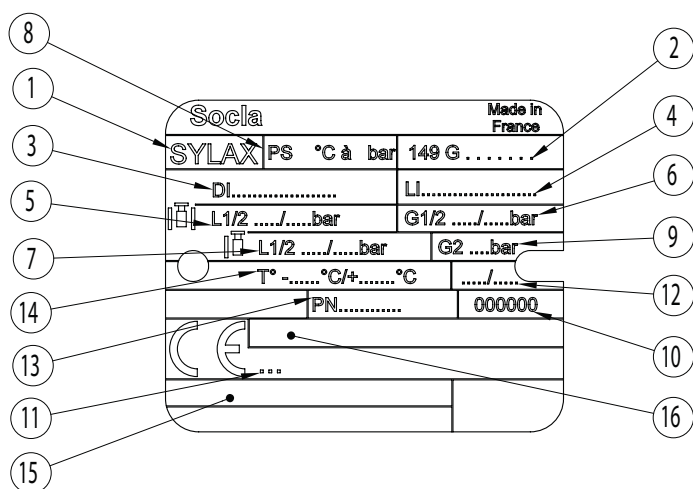

Rep	Description
1	Name of the valve
2	Reference
3	Material of the disc
4	Material of the liner
5	Pressure PS between flanges L1/L2 (liquid)
6	Pressure PS between flanges G1/G2 (gas)
7	Pressure PS end flange L1/L2 (liquid)
8	Pressure PFA water 20°C
9	Pressure PS end flange G2 (gas)
10	Number of manufacturing order
11	Notified Body Number for the Directive PED 97/23/CE
12	Manufacturing date
13	Connecting flanges
14	Limit of use
15	Approval information zone
16	Marking relating to the Directive ATEX 94/9/CE

Bolts and nuts
Note : Bolts and nuts are not part of our standard supply.

DN	NPS	a	e	EN 1092 PN6			EN 1092 PN10			EN 1092 PN16			EN 1092 PN25			ASME / ANSI B16.5 Class 150			
				*Nb rods or Nb screw	ØV	c	*Nb rods or Nb screw	ØV	c	*Nb rods or Nb screw	ØV	c	*Nb rods or Nb screw	ØV	c	*Nb rods or Nb screw	ØV metric	ØV UNC**	c
25	1	32	--	4	M10	16	4	M12	18	4	M12	18	4	M12	18	4	M14	1/2»	18
32/40	1 1/2	32	14	4	M12	18	4	M16	24	4	M16	24	4	M16	24	4	M14	1/2»	18
50	2	43	18	4	M12	18	4	M16	24	4	M16	24	4	M16	24	4	M16	5/8»	24
65*	2 1/2	46	20	4	M12	18	8*	M16	24	8*	M16	24	8	M16	24	4	M16	5/8»	24
80	3	46	20	4	M16	24	8	M16	24	8	M16	24	8	M16	24	4	M16	5/8»	24
100	4	52	24	4	M16	24	8	M16	24	8	M16	24	8	M20	26	8	M16	5/8»	24
125	5	56	26	8	M16	24	8	M16	24	8	M16	24	8	M24	32	8	M20	3/4»	26
150	6	56	26	8	M16	24	8	M20	26	8	M20	26	8	M24	32	8	M20	3/4»	26
200	8	60	28	8	M16	24	8	M20	26	12	M20	26	12	M24	32	8	M20	3/4»	26
250	10	68	32	12	M16	24	12	M20	26	12	M24	32	12	M27	32	12	M24	7/8»	26
300	12	78	36	12	M20	26	12	M20	26	12	M24	32	16	M27	32	12	M24	7/8»	26
350	14	78	36	12	M20	26	16	M20	26	16	M24	32	16	M30	36	12	M27	1»	32

* For flanges in cast or ductile iron 4 holes M16 and for flanges in steel 8 holes M16 on the same drilling circle.

DN	NPS	a	e	BS10-d			BS10-e			JIS2238 & JIS2239 5K			JIS2238 & JIS2239 10K			JIS2238 & JIS2239 16K		
				*Nb rods or Nb screw	ØV UNC	c	*Nb rods or Nb screw	ØV UNC	c	*Nb rods or Nb screw	ØV	c	*Nb rods or Nb screw	ØV	c	*Nb rods or Nb screw	ØV	c
25	1	32	--	4	1/2»	18	4	1/2»	18	4	M10	16	4	M16	24	4	M16	24
32/40	1 1/2	32	14	4	1/2»	18	4	1/2»	18	4	M12	18	4	M16	24	4	M16	24
50	2	43	18	4	5/8»	24	4	5/8»	24	4	M12	18	4	M16	24	8	M16	24
65	2 1/2	46	20	4	5/8»	24	4	5/8»	24	4	M12	18	4	M16	24	8	M16	24
80	3	46	20	4	5/8»	24	4	5/8»	24	4	M16	24	8	M16	24	8	M20	26
100	4	52	24	4	5/8»	24	8	5/8»	24	8	M16	24	8	M16	24	8	M20	26
125	5	56	26	8	5/8»	24	8	5/8»	24	8	M16	24	8	M20	26	8	M22	26
150	6	56	26	8	5/8»	24	8	3/4»	26	8	M16	24	8	M20	26	12	M22	26
200	8	60	28	8	5/8»	24	8	3/4»	26	8	M20	26	12	M20	26	12	M22	26
250	10	68	32	8	3/4»	26	12	3/4»	26	12	M20	26	12	M22	26	12	M24	32
300	12	78	36	12	3/4»	26	12	7/8»	26	12	M20	26	16	M22	26	16	M24	32
350	14	78	36	12	7/8»	26	12	7/8»	26	12	M22	26	16	M22	26	16	M30x3	36

* WAFER TYPE BODY, CENTRAL FLANGE BODY AND RING SHAPED TYPE BODY :

Assembly by rods : number of nuts and washer = 2 x Number of rods (above)

Assembly by bolts : Number of nuts = Number of screws (above) and number of washer = 2 x Number of nuts

* LUG TYPE BODY :

Assembly by screws : Number of screw per face (above) and number of washer is the same

* DOUBLE FLANGE BODY :

Assembly by rods : number of nuts and washers = 2 x Number of rods (above)

Assembly by rods + central nut :

Number of nuts = 2 x Number of rods (above)

Number of washers = 4 x Number of rods (above)

Number of thin nuts for central position = 1 x Number of rods (above)

** ASME / ANSI B16.5 Class 150 : **Standard** version : metric threading; UNC threading : please consult us.

Bolts and nuts

For wafer type and central flange type body ; assembly by rods :

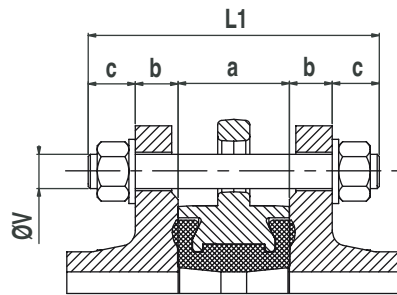

L1 = a + 2(b+c)

L1 = minimum length of rods

a = width of the butterfly valve (face to face dimension)

b = thickness of the flange (customer)

c = thickness of washer + thickness of nut + exceeding length of the rod.

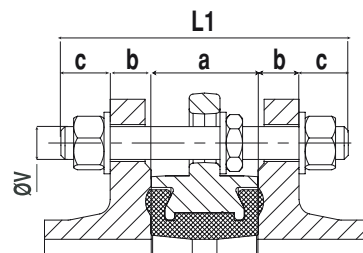

Mounting in case of downstream pipework dismantling (see page 9).

Use nuts with reduced face-to-face dimensions between the butterfly valve and the downstream flange.

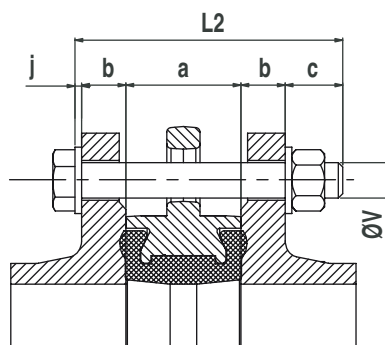

For wafer type and central flange type body ; assembly by bolts :

L2 = a + 2b + c + j

L2 = minimum length under head of screw

a = width of the butterfly valve

b = thickness of the flange (customer)

c = thickness of washer + thickness of nut + exceeding length of the rod

j = thickness of washer at the head of the screw.

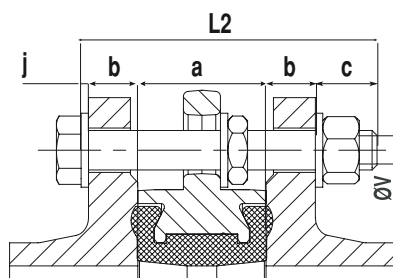

Mounting in case of downstream pipework dismantling (see page 9).

Use nuts with reduced face-to-face dimensions between the butterfly valve and the downstream flange.

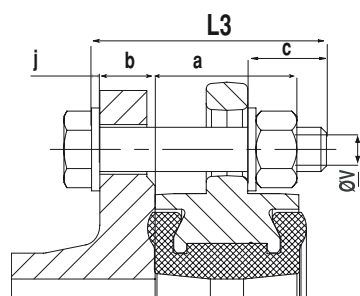

For ring shaped type body ; assembly by rods :

L3 = a + 2(b+c)

L3 = minimum length under head of screw

a = width of the butterfly valve (face to face dimension)

b = thickness of the flange (customer)

c = thickness of washer + thickness of nut + exceeding length of the rod