

# Air-Operated Diaphragm Pumps

819.6900

Rev. ZAA  
EN

**For fluid transfer applications. For professional use only.**

100 psi; 0.7 MPa; 7 bar Maximum Fluid Working Pressure

100 psi; 0.7 MPa; 7 bar Maximum Air Input Pressure

POLYPROPYLENE, AND PVDF

## **VERDERAIR VA 15**

ACETAL\* AND CONDUCTIVE POLYPROPYLENE\*

## **VERDERAIR VA 15**

\*These pumps are  certified.

ALUMINUM AND STAINLESS STEEL\*

## **VERDERAIR VA 20**

\*These pumps are  certified.

Refer to the Pump Listing on page 20 to determine the Model No. of your pump.

Patents Pending

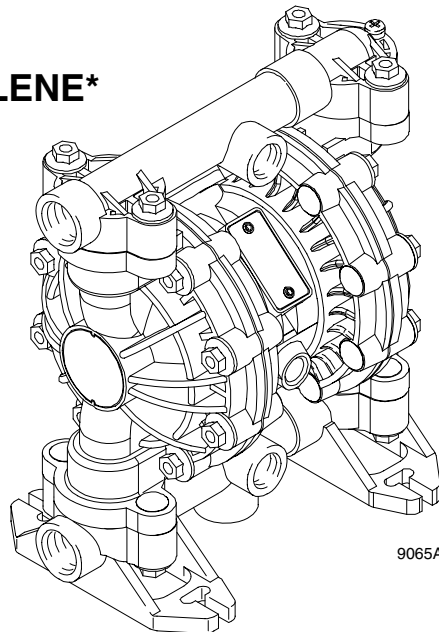

9065A

**VERDERAIR VA 15**



### **Important Safety Instructions**

Read all warnings and instructions in this manual.  
Save these instructions.

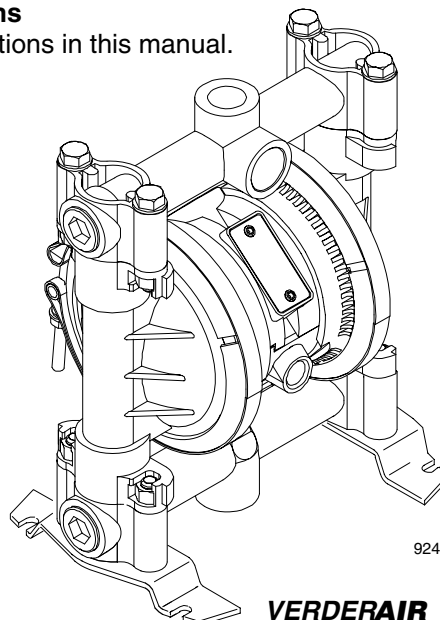

9246A

**VERDERAIR VA 20**



# Table of Contents

Safety Warnings .....	2
Installation .....	4
Operation .....	10
Maintenance .....	11
Troubleshooting .....	12
Service .....	13
<i>VERDERAIR VA 15 and VERDERAIR VA 20</i>	
Pump Listing .....	20
<i>VERDERAIR VA 15 and VERDERAIR VA 20</i>	
Repair Kits .....	23
<b>Parts</b>	
<i>VERDERAIR VA 15 and VERDERAIR VA 20</i>	
Common Parts .....	24
<i>VERDERAIR VA 15</i> Parts Drawing .....	25
<i>VERDERAIR VA 15</i> Fluid Section Parts List .....	26
<i>VERDERAIR VA 20</i> Parts Drawing .....	28
<i>VERDERAIR VA 20</i> Fluid Section Parts List .....	29
Torque Sequence .....	30
<b>VERDERAIR VA 15:</b>	
Technical Data .....	31
Dimensions .....	32
<b>VERDERAIR VA 20:</b>	
Technical Data .....	33
Dimensions .....	34
<i>VERDERAIR VA 15 and VERDERAIR VA 20</i>	
Performance Charts .....	35
Customer Services/Guarantee .....	37

# Symbols

## Warning Symbol



This symbol alerts you to the possibility of serious injury or death if you do not follow the instructions.

## Caution Symbol



This symbol alerts you to the possibility of damage to or destruction of equipment if you do not follow the instructions.

# Warning



INSTRUCTIONS

## EQUIPMENT MISUSE HAZARD

Equipment misuse can cause the equipment to rupture or malfunction and result in serious injury.

- This equipment is for professional use only.
- Read all instruction manuals, tags, and labels before operating the equipment.
- Use the equipment only for its intended purpose. If you are not sure, call your VERDER distributor.
- Do not alter or modify this equipment. Use only genuine VERDER parts and accessories.
- Check equipment daily. Repair or replace worn or damaged parts immediately.
- Do not exceed the maximum working pressure of the lowest rated component in your system. This equipment has a **100 psi; 0.7 MPa (7 bar) maximum working pressure at 100 psi; 0.7 MPa (7 bar) maximum incoming air pressure.**
- Use fluids and solvents that are compatible with the equipment wetted parts. Refer to the **Technical Data** section of all equipment manuals. Read the fluid and solvent manufacturer's warnings.
- Route hoses away from traffic areas, sharp edges, moving parts, and hot surfaces. Do not expose VERDER hoses to temperatures above 180°F (82°C) or below -40°C (-40°C).
- Wear hearing protection when operating this equipment.
- Do not lift pressurized equipment.
- Comply with all applicable local, state, and national fire, electrical, and safety regulations.
- Do not use 1.1.1-trichloroethane, methylene chloride, other halogenated hydrocarbon solvents or fluids containing such solvents in pressurized aluminum equipment. Such use could result in a chemical reaction, with the possibility of explosion.

# Warning



## TOXIC FLUID HAZARD

Hazardous fluid or toxic fumes can cause serious injury or death if splashed in the eyes or on the skin, inhaled, or swallowed.



- Know the specific hazards of the fluid you are using.
- Do not lift a pump under pressure. If dropped, the fluid section may rupture. Always follow the **Pressure Relief Procedure** on page 10 before lifting the pump.
- Store hazardous fluid in an approved container. Dispose of hazardous fluid according to all local, state, and national guidelines.
- Always wear protective eyewear, gloves, clothing, and respirator as recommended by the fluid and solvent manufacturer.
- Pipe and dispose of the exhaust air safely, away from people, animals, and food handling areas. If the diaphragm fails, the fluid is exhausted along with the air. Read **Air Exhaust Ventilation** on page 6.
- **Never** use an acetal pump to pump acids. Take precautions to avoid acid or acid fumes from contacting the pump housing exterior. Stainless steel parts will be damaged by exposure to acid spills and fumes.



## FIRE AND EXPLOSION HAZARD

Improper grounding, poor ventilation, open flames, or sparks can cause a hazardous condition and result in a fire or explosion and serious injury.



- Ground the equipment. Refer to **Grounding** on page 8.
- **Never** use a non-conductive polypropylene or PVDF pump with non-conductive flammable fluids as specified by your local fire protection code. Refer to **Grounding** on page 8 for additional information. Consult your fluid supplier to determine the conductivity or resistivity of your fluid.
- If there is any static sparking or you feel an electric shock while using this equipment, **stop pumping immediately**. Do not use the equipment until you identify and correct the problem.
- Provide fresh air ventilation to avoid the buildup of flammable fumes from solvents or the fluid being pumped.
- Pipe and dispose of the exhaust air safely, away from all sources of ignition. If the diaphragm fails, the fluid is exhausted along with the air. Read **Air Exhaust Ventilation** on page 6.
- Keep the work area free of debris, including solvent, rags, and gasoline.
- Electrically disconnect all equipment in the work area.
- Extinguish all open flames or pilot lights in the work area.
- Do not smoke in the work area.
- Do not turn on or off any light switch in the work area while operating or if fumes are present.
- Do not operate a gasoline engine in the work area.

# Installation

## General Information

- The Typical Installations in Fig. 2 are only guides for selecting and installing system components. Contact your VERDER distributor for assistance in planning a system to suit your needs.
- Always use Genuine VERDER Parts and Accessories.
- Use a compatible, liquid thread sealant on all male threads. Tighten all connections firmly to avoid air or fluid leaks.

## Tightening Threaded Fasteners Before First Use

Before using the pump for the first time, check and retorque all external fasteners. See **Torque Sequence**, page 30. After the first day of operation, retorque the fasteners. Although pump use varies, a general guideline is to retorque fasteners every two months.

## Toxic Fluid Hazard



Read **Toxic Fluid Hazard** on page 3.

Use fluids and solvents that are compatible with the equipment wetted parts. Refer to the **Technical Data** section of all equipment manuals. Read the fluid and solvent manufacturer's warnings.

## **Caution**

### Safe Operating Temperatures

*Minimum (all pumps): 40° F (4° C)*

*Maximum*

*Acetal: 180° F (82° C)*

*Polypropylene: 150° F (66° C)*

*Aluminum, stainless steel, PVDF: 225° F (107° C)*

These temperatures are based upon mechanical stress only and may be significantly altered by pumping certain chemicals. Consult engineering guides for chemical compatibilities and temperature limits, or contact your VERDER distributor.

## Mountings

- These pumps can be used in a variety of installations. Be sure the mounting surface can support the weight of the pump, hoses, and accessories, as well as the stress caused during operation.
- Fig. 2 shows some installation examples. On all installations, mount the pump using screws and nuts.

## Pumping High-Density Fluids

High density fluids may prevent the lighter non-metallic check valve balls from seating properly, which reduces pump performance significantly. Stainless steel balls should be used for such applications.

# Installation

## Air Line

### Warning

A bleed-type master air valve (B) is required in your system to relieve air trapped between this valve and the pump. See Fig. 2. Trapped air can cause the pump to cycle unexpectedly, which could result in serious injury, including splashing in the eyes or on the skin, injury from moving parts, or contamination from hazardous fluids.

### Caution

The pump exhaust air may contain contaminants. Ventilate to a remote area if the contaminants could affect your fluid supply. Read Air Exhaust Ventilation on page 6.

1. Install the air line accessories as shown in Fig. 2. Mount these accessories on the wall or on a bracket. Be sure the air line supplying the accessories is electrically conductive.
  - a. The fluid pressure can be controlled in either of two ways. To control it on the air side, install an air regulator (G). To control it on the fluid side, install a fluid regulator (J) near the pump fluid outlet (see Fig. 2).
  - b. Locate one bleed-type master air valve (B) close to the pump and use it to relieve trapped air. Read the **Warning** above. Locate the other master air valve (E) upstream from all air line accessories and use it to isolate them during cleaning and repair.
  - c. The air line filter (F) removes harmful dirt and moisture from the compressed air supply.
2. Install an electrically conductive, flexible air hose (C) between the accessories and the 1/4 npt(f) pump air inlet. Use a minimum 1/4 in. ID air hose. Screw an air line quick disconnect coupler (D) onto the end of the air hose (C), and screw the mating fitting into the pump air inlet snugly. Do not connect the coupler (D) to the fitting yet.

## Installation of Remote Pilot Airlines

1. Connect the air line to the pump as noted above.
2. Connect 1/4 OD tubing to the push type connectors (16) on the underside of the pump.

**NOTE:** By replacing the push type connectors, other sizes or types of fittings may be used. The new fittings will require 1/8 in. npt threads.

3. Connect the other end of the tubes to the external air signal, such as VERDER's Cycleflo (PN 819.9742) or Cycleflo II (819.9743) controllers.

**NOTE:** The air pressure at the connectors must be at least 30% of the air pressure to the air motor for the pump to operate.

## Fluid Suction Line

- If using a conductive (acetal or polypropylene) pump, use conductive hoses. If using a non-conductive pump, ground the fluid system. Read **Grounding** on page 8. The fluid inlet port is 1/2 in. or 3/4 in..
- At inlet fluid pressures greater than 15 psi; 0.1 MPa (1 bar), diaphragm life will be shortened.

## Fluid Outlet Line

### Warning

A fluid drain valve (H) is required in your system to relieve pressure in the hose if it is plugged. See Fig. 2. The drain valve reduces the risk of serious injury, including splashing in the eyes or on the skin, or contamination from hazardous fluids when relieving pressure. Install the valve close to the pump fluid outlet.

1. Use electrically conductive fluid hoses (K). The pump fluid outlet is 1/2 in. or 3/4 in. Screw the fluid fitting into the pump outlet snugly. **Do not over-tighten.**
2. Install a fluid regulator (J) at the pump fluid outlet to control fluid pressure, if desired (see Fig. 2). See **Air Line**, step 1a., for another method of controlling pressure.
3. Install a fluid drain valve (H) near the fluid outlet. Read the **warning** above.

# Installation



## Fluid Pressure Relief Valve

### Caution

Some systems may require installation of a pressure relief valve at the pump outlet to prevent over-pressurization and rupture of the pump or hose. See Fig. 1.

Thermal expansion of fluid in the outlet line can cause over-pressurization. This can occur when using long fluid lines exposed to sunlight or ambient heat, or when pumping from a cool to a warm area (for example, from an underground tank).

Over-pressurization can also occur if the **VERDERAIR** pump is being used to feed fluid to a piston pump, and the intake valve of the piston pump does not close, causing fluid to back up in the outlet line.

-  Install valve between fluid inlet and outlet ports.
-  Connect fluid inlet line here.
-  Connect fluid outlet line here.

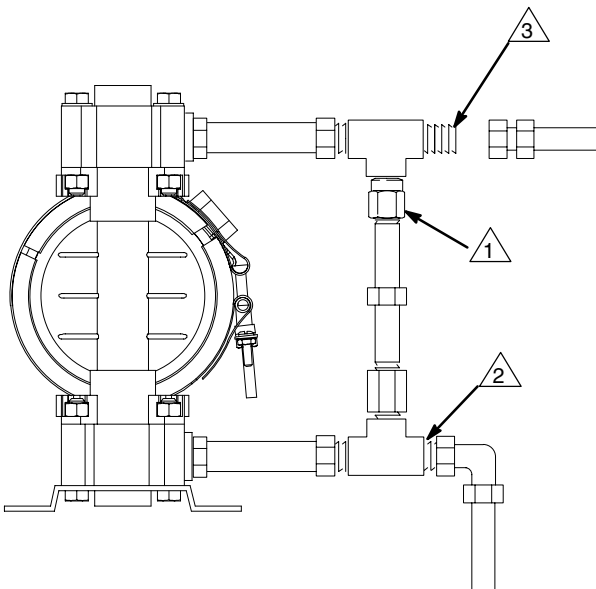

Fig. 1 9073A

## Air Exhaust Ventilation



Read **Toxic Fluid Hazard** on page 3.



Read **Fire and Explosion Hazard** on page 3.

Be sure the system is properly ventilated for your type of installation. You must vent the exhaust to a safe place, away from people, animals, food handling areas, and all sources of ignition when pumping flammable or hazardous fluids.

Diaphragm failure will cause the fluid being pumped to exhaust with the air. Place an appropriate container at the end of the air exhaust line to catch the fluid. See Fig. 2.

The air exhaust port is 3/8 npt(f). Do not restrict the air exhaust port. Excessive exhaust restriction can cause erratic pump operation.

See **Venting Exhaust Air** in Fig. 2. Exhaust to a remote location as follows:

1. Remove the muffler (W) from the pump air exhaust port.
2. Install an electrically conductive air exhaust hose (X) and connect the muffler to the other end of the hose. The minimum size for the air exhaust hose is 3/8 in.(10 mm) ID. If a hose longer than 15 ft (4.57 m) is required, use a larger diameter hose. Avoid sharp bends or kinks in the hose.
3. Place a container (Z) at the end of the air exhaust line to catch fluid in case a diaphragm ruptures. See Fig. 2.

# Installation

## ABOVE-GROUND TRANSFER INSTALLATION

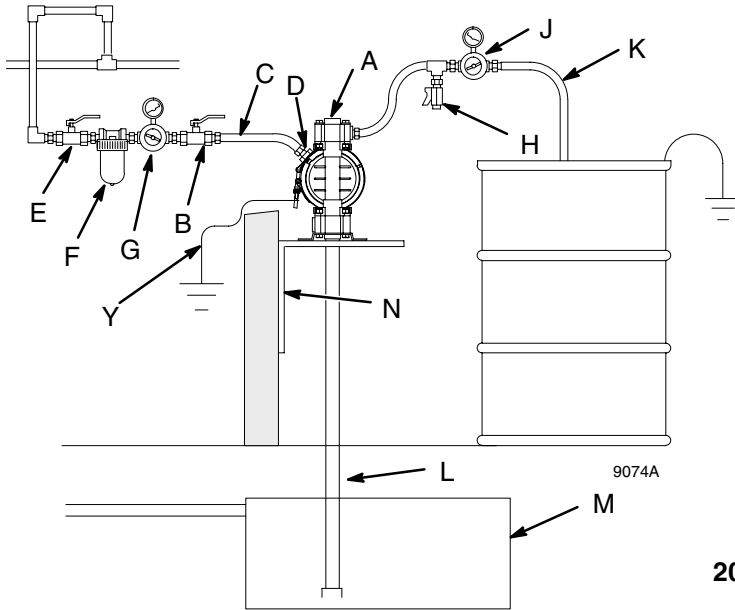

### KEY

- A Pump
- B Bleed-type master air valve (required for pump)
- C Electrically conductive air supply line
- D Air line quick disconnect
- E Master air valve (for accessories)
- F Air line filter
- G Pump air regulator
- H Fluid drain valve (required)
- J Fluid regulator (optional)
- K Electrically conductive fluid supply hose
- L Fluid suction line
- M Underground storage tank
- N Wall mounting bracket
- Y Ground wire (required; see page 8 for installation instructions)

## 208-LITER BUNG PUMP INSTALLATION

### KEY

- A Pump
- C Electrically conductive air supply line
- D Air line quick disconnect
- H Fluid drain valve (required)
- K Electrically conductive fluid supply hose
- L Fluid suction line
- Y Ground wire (required; see page 8 for installation instructions)

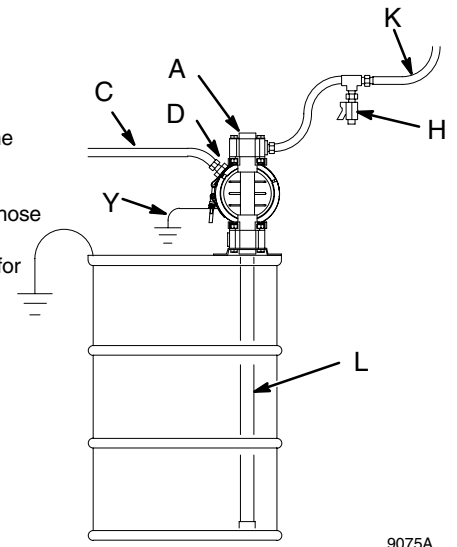

## AIR SPRAY INSTALLATION

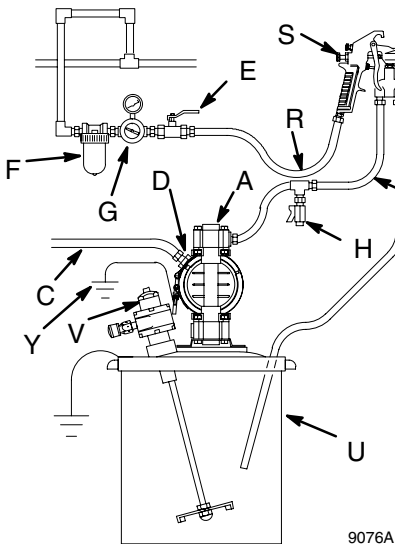

### KEY

- A Pump
- C Electrically conductive air line to pump
- E Gun air line shutoff valve
- F Air line filter
- G Gun air regulator
- H Fluid drain valve (required)
- K Electrically conductive fluid supply hose
- P Circulating valve
- R Electrically conductive air line to gun
- S Air spray gun
- T Electrically conductive fluid return line
- U 19-liter pail
- V Agitator
- Y Ground wire (required; see page 8 for installation instructions)

### KEY

- W Muffler
- X Electrically Conductive Air Exhaust Hose
- Z Container for Remote Air Exhaust

All wetted and non-wetted pump parts must be compatible with the fluid being pumped.

## VENTING EXHAUST AIR

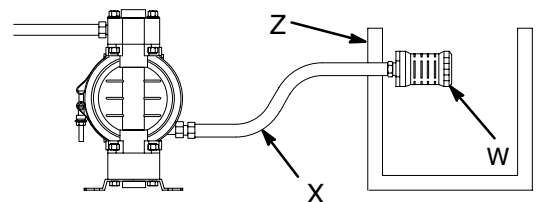

Fig. 2

# Installation

## Grounding

### Warning



#### FIRE AND EXPLOSION HAZARD

This pump must be grounded. Before operating the pump, ground the system as explained below. Also read the section **Fire and Explosion Hazard** on page 3.



The *acetal and conductive polypropylene VERDERAIR VA 15 pumps* contain a conductive additive that makes the wetted parts con-

ductive. Attaching the ground wire to the grounding screw (106) grounds the wetted parts. See **grounding screw** on page 25.

The *metal VERDERAIR VA 20 pumps* have a grounding strip connecting the vee clamps (109). Attach a ground wire to the grounding strip with the screw, lockwasher, and nut as shown in the **Grounding Detail** on page 28.

The *non-conductive polypropylene and PVDF VERDERAIR VA 15 pumps* are **not** conductive.

When pumping conductive flammable fluids, **always** ground the entire fluid system by making sure the fluid system has an electrical path to a true earth ground (see Fig. 3). **Never** use a non-conductive polypropylene or PVDF pump with non-conductive flammable fluids as specified by your local fire protection code.

US Code (NFPA 77 Static Electricity) recommends a conductivity greater than  $50 \times 10^{-12}$  Siemens/meter (ohms/meter) over your operating temperature range to reduce the hazard of fire. Consult your fluid supplier to determine the conductivity or resistivity of your fluid. The resistivity must be less than  $2 \times 10^{12}$  ohm-centimeters.

To reduce the risk of static sparking, ground the pump and all other equipment used or located in the pumping area. Check your local electrical code for detailed grounding instructions for your area and type of equipment.

**NOTE:** When pumping conductive flammable fluids with a non-conductive polypropylene or PVDF pump, **always** ground the fluid system. See the **warning** above. Fig. 3 shows a recommended method of grounding flammable fluid containers during filling.



### Ground all of this equipment:

- **Pump:** The metal pump has a grounding strip in front of the center housing. The acetal and conductive polypropylene pumps have a grounding screw on the top manifold. Connect the non-clamp end of the ground wire to the grounding strip or grounding screw, and connect the clamp end of the ground wire to a true earth ground. To order a ground wire and clamp, order Part No. 819.0157.
- **Air and fluid hoses:** Use only electrically conductive hoses.
- **Air compressor:** Follow the manufacturer's recommendations.
- **Solvent pails used when flushing:** Follow the local code. Use only grounded metal pails, which are conductive. Do not place the pail on a non-conductive surface, such as paper or cardboard, which interrupts the grounding continuity.
- **Fluid supply container:** Follow the local code.

## GROUNDING A PUMP

### KEY

- A Pump
- H Fluid drain valve (required)
- S Dispense valve
- T Fluid drain line
- Y Fluid section grounding via grounding strip or grounding screw (required for metal and acetal pumps)
- Z Container ground wire (required)

-  1 Hose must be conductive.
-  2 Dispense valve nozzle must be in contact with container.

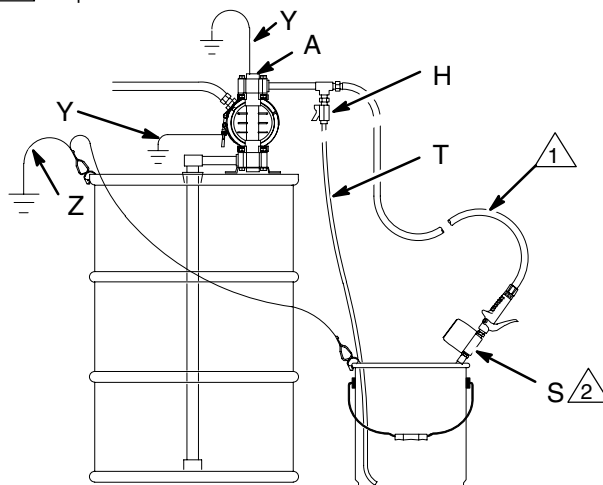

Fig. 3

9079A



# Installation

## Changing the Orientation of the Fluid Inlet and Outlet Ports (*VERDERAIR VA 15*)

You can change the orientation of the fluid inlet and outlet ports by repositioning the manifolds. For *VERDERAIR VA 15*, see Fig. 4. For *VERDERAIR VA 20*, see Fig. 5.

1. Remove the four manifold nuts (109) or bolts (105).
2. Turn the manifold to the desired position, reinstall the nuts or bolts, and torque to 80 to 90 in-lb (9 to 10 N•m). See **Torque Sequence**, page 30.

**NOTE:** Make sure all manifold o-rings are positioned correctly before you fasten the manifold. Manifold o-rings (139) are shown in Fig. 7 and Fig. 8.

**NOTE:** Pumps with duckbill check valves are shipped with the inlet manifold on top and the outlet manifold on the bottom. See page 14 for details.

 Torque to 80 to 90 in-lb (9 to 10 N•m). See **Torque Sequence**, page 30.

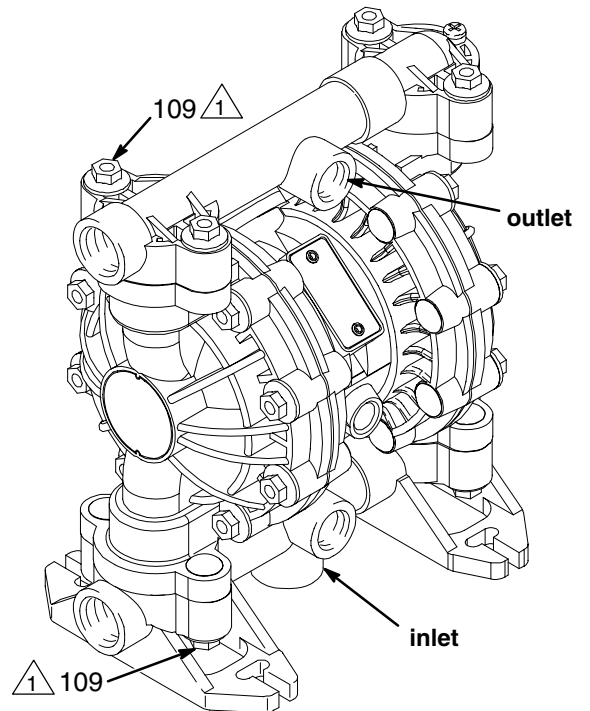



Fig. 4

9065A

 Torque to 80 to 90 in-lb (9 to 10 N•m). See **Torque Sequence**, page 30.

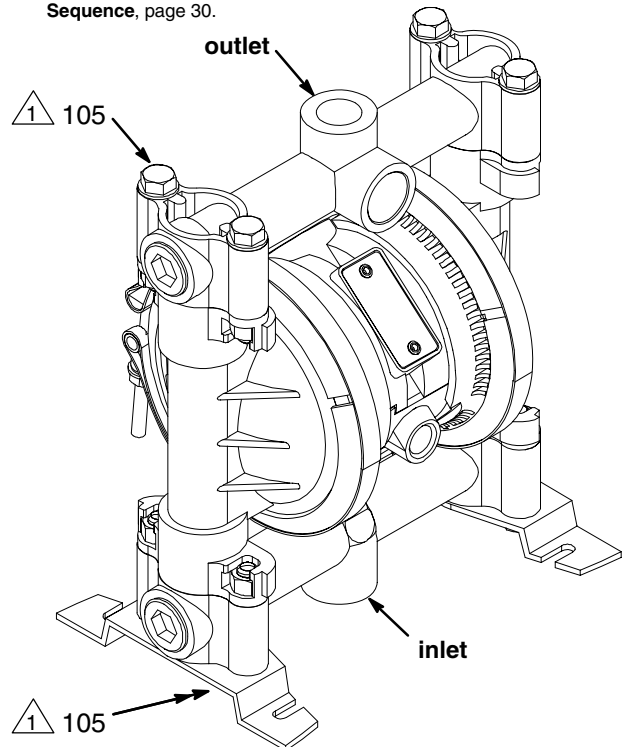

Fig. 5

9071A

# Operation

## Pressure Relief Procedure

### Warning

#### PRESSURIZED EQUIPMENT HAZARD







The equipment stays pressurized until pressure is manually relieved. To reduce the risk of serious injury from pressurized fluid, accidental spray, or splashing fluid, follow this procedure whenever you:

- Are instructed to relieve pressure;
  - Stop pumping;
  - Check, clean or service any system equipment;
  - Install or clean fluid nozzles.
1. Shut off the air to the pump.
  2. Open the dispensing valve, if used.
  3. Open the fluid drain valve to relieve all fluid pressure, and have a container ready to catch the drainage.

## Flush the Pump Before First Use

The pump was tested with water. Prior to first use, flush the pump thoroughly with a compatible solvent. Follow the steps under **Starting and Adjusting the Pump**.

## Starting and Adjusting the Pump

1.   Read **Toxic Fluid Hazard** on page 3.
2.  If lifting the pump, follow the **Pressure Relief Procedure** above.
3.    Be sure the pump is properly grounded. Read **Fire and Explosion Hazard** on page 3.

4. Check all fittings to be sure they are tight. Use a compatible liquid thread sealant on all male threads. Tighten the fluid inlet and outlet fittings snugly. Do not over-tighten the fittings into the pump.

5. Place the suction tube (if used) in the fluid to be pumped.

**NOTE:** If the inlet fluid pressure to the pump is more than 25% of the outlet working pressure, the ball check valves will not close fast enough, resulting in inefficient pump operation.

6. Place the end of the fluid hose (K) into an appropriate container.
7. Close the fluid drain valve (H).
8. With the pump air regulator (G) closed, open all bleed-type master air valves (B, E).
9. If the fluid hose has a dispensing device, hold it open while continuing with the following step. Slowly open the air regulator (G) until the pump starts to cycle. Allow the pump to cycle slowly until all air is pushed out of the lines and the pump is primed.

*If you are flushing, run the pump long enough to thoroughly clean the pump and hoses. Close the air regulator. Remove the suction tube from the solvent and place it in the fluid to be pumped.*

## Operation of Remote Piloted Pumps

1. Follow steps 1–8 above.
2. Open the air regulator (G).

### Warning

The pump may cycle once before the external signal is applied.

3. The pump will operate when air pressure is alternately applied to the push type connectors (16).

**NOTE:** Leaving air pressure applied to the air motor for extended periods when the pump is not running may shorten the diaphragm life. Using a 3-way solenoid valve to automatically relieve the pressure on the air motor when the metering cycle is complete prevents this from occurring.

## Pump Shutdown

 At the end of the work shift, **relieve the pressure** as described in **Pressure Relief Procedure** at left.

# Maintenance

## Lubrication

The air valve is lubricated at the factory to operate without additional lubrication. If you want to provide additional lubrication, remove the hose from the pump air inlet and add two drops of machine oil to the air inlet every 500 hours of operation or every month.

### **Caution**

Do not over-lubricate the pump. Oil is exhausted through the muffler, which could contaminate your fluid supply or other equipment. Excessive lubrication can also cause the pump to malfunction.

## Flushing and Storage

Flush the pump to prevent the fluid you are pumping from drying or freezing in the pump and damaging it. Use a compatible solvent.

Always flush the pump and **relieve the pressure** before you store it for any length of time.



Read **Pressure Relief Procedure** on page 10.

## Tightening Threaded Connections

Before each use, check all hoses for wear or damage and replace as necessary. Check to be sure all threaded connections are tight and leak-free.

Check fasteners. Tighten or retorque as necessary. Although pump use varies, a general guideline is to retorque fasteners every two months. See **Torque Sequence**, page 30.

## Preventive Maintenance Schedule

Establish a preventive maintenance schedule, based on the pump's service history. This is especially important for prevention of spills or leakage due to diaphragm failure.

# Troubleshooting



Read **Pressure Relief Procedure** on page 10, and **relieve the pressure** before you check or service the equipment. Check all possible problems and causes before disassembling the pump.

PROBLEM	CAUSE	SOLUTION
Pump will not cycle, or cycles once and stops.	Air valve is stuck or dirty.	Use filtered air.
Pump cycles at stall or fails to hold pressure at stall.	Leaky check valves or o-rings.	Replace.
	Worn check balls or duckbill valves or guides.	Replace.
	Check ball wedged in guide.	Repair or replace.
	Worn diaphragm shaft seals.	Replace.
Pump operates erratically.	Clogged suction line.	Inspect; clear.
	Sticky or leaking check valve balls.	Clean or replace.
	Diaphragm ruptured.	Replace.
Air bubbles in fluid.	Suction line is loose.	Tighten.
	Diaphragm ruptured.	Replace.
	Loose manifolds or damaged manifold o-rings.	Tighten manifold bolts or nuts; replace o-rings.
	Loose fluid side diaphragm plates.	Tighten.
Fluid in exhaust air.	Diaphragm ruptured.	Replace.
	Loose fluid side diaphragm plates.	Tighten.
	Worn diaphragm shaft seals.	Replace.
Pump exhausts air from clamps (metal pumps).	Loose clamps.	Tighten clamp nuts.
	Air valve o-ring is damaged.	Inspect; replace.
Pump leaks fluid from check valves.	Worn or damaged check valve o-rings.	Inspect; replace.

# Service

## Air Valve (VERDERAIR VA 15 and VERDERAIR VA 20 Pumps)

**NOTE:** Air Valve Repair Kit 819.9740 is available. Parts included in the kit are marked with a dagger (†) in Fig. 6 and in the Parts Drawings and Lists. A tube of general purpose grease 819.0184 is supplied in the kit. Service the air valve as follows. See Fig. 6.



1. **Relieve the pressure.** See **Pressure Relief Procedure** on page 10.

2. Remove the cover (10) and the o-ring (4).
3. Remove the carriage plungers (7), carriages (8), carriage pins (9), and valve plate (14) from the center housing (11).
4. Clean all the parts, and inspect them for wear or damage.

**NOTE:** If you are installing the new Air Valve Repair Kit 819.9740, use all the parts in the kit.

5. Grease the lapped surface of the valve plate (14), and install the valve plate with the lapped surface facing up.
6. Grease the bores of the center housing (11), install the u-cup packings (2) on the carriage plungers (7), and slide the carriage plungers into the carriage plunger bores. See the following important installation notes:

### NOTES:

- When you install each u-cup packing (2) on each carriage plunger (7), make sure the lips of the u-cup packing face toward the **clip end** (the smaller end) of the carriage plunger.
  - When you slide the carriage plungers (7) into the bores, slide them in with the clip ends (the smaller ends) facing toward the center of the center housing (11).
7. Grease the carriage pins (9), and slide the carriage pins into the carriage pin bores.
  8. Install the carriages (8). Make sure the carriages engage the clip ends of the carriage plungers (7) and carriage pins (9).
  9. Grease the o-ring (4), and seat it in the groove around the cover opening of the center housing (11).
  10. Screw cover (10) into center housing, and torque cover from 80 to 100 in-lb (9.0 to 13.6 N•m).

**NOTE:** Center housing (11) is shown separated from the air covers, but it is not necessary to remove the air covers for this service. Leave the center housing and air covers assembled for this service.

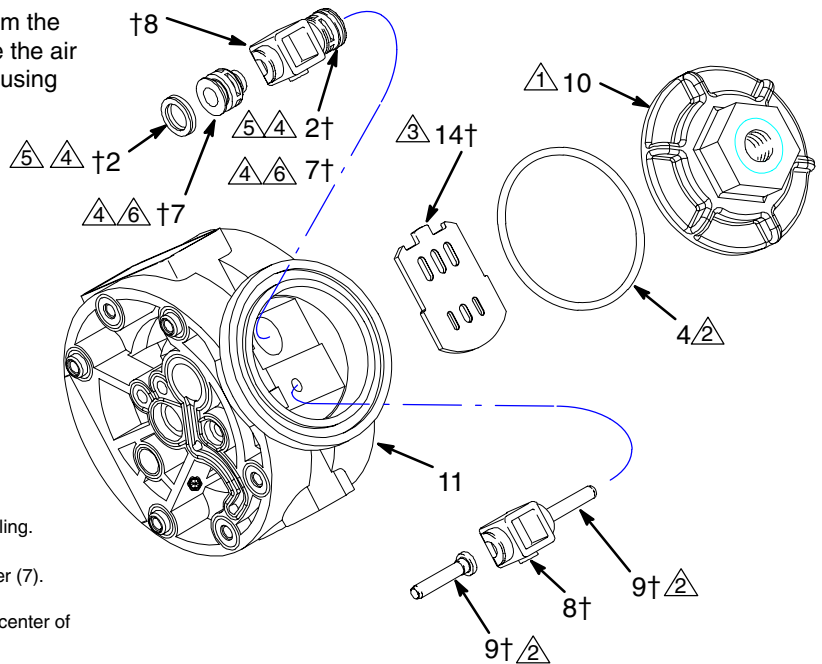

† Included in Air Valve Repair Kit 819.9740.

- 1 Torque to 80 to 100 in-lb (9.0 to 13.6 N•m).
- 2 Apply grease.
- 3 Apply grease to lapped face.
- 4 Apply grease to bores of center housing (11) before installing.
- 5 Seal lips face clip end (the smaller end) of carriage plunger (7).
- 6 Install with the clip ends (the smaller ends) facing toward center of center housing (11).

**Fig. 6**

9069A

# Service

## Ball or Duckbill Check Valves

**NOTE:** Fluid Section Repair Kit is available. See page 23 to order the correct kit for your pump. Parts included in the kit are marked with a double dagger (‡) in Fig. 7 and Fig. 8 and in the Parts Drawings and Lists. General purpose grease 819.0184 and Adhesive 819.9741 are supplied in the kit.



1. **Relieve the pressure.** See **Pressure Relief Procedure** on page 10.

2. Remove the top and bottom manifolds (102, 103).
3. Remove all parts shown with a dagger (‡) in Fig. 7 and Fig. 8.
4. Clean all parts, and replace worn or damaged parts.
5. Reassemble the pump.

**NOTE:** Torque the manifold nuts (109) or bolts (105) to 80 to 90 in-lb (9 to 10 N•m). See **Torque Sequence**, page 30.

## Inlet and Outlet for Pumps with Duckbill Check Valves

Pumps with duckbill check valves are shipped with the inlet manifold on top and the outlet manifold on the bottom. To make the inlet manifold on the bottom and the outlet manifold on the top, rotate each of the four duckbill assemblies vertically 180° as shown below.

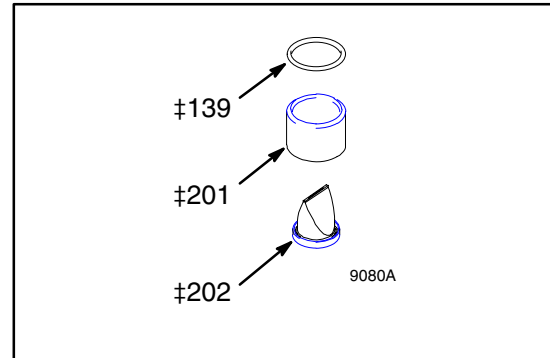

# Service

## VERDERAIR VA 15

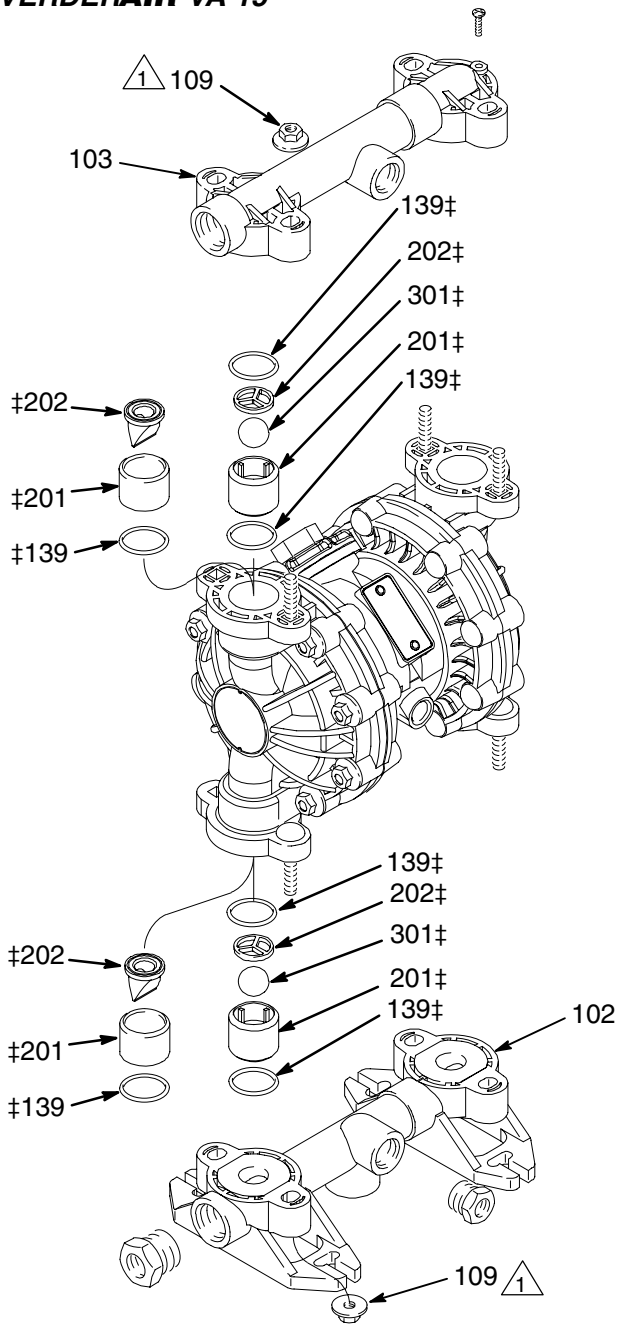

1 Torque to 80 to 90 in-lb (9 to 10 N•m).  
See **Torque Sequence**, page 30.

Fig. 7

9067A

## VERDERAIR VA 20

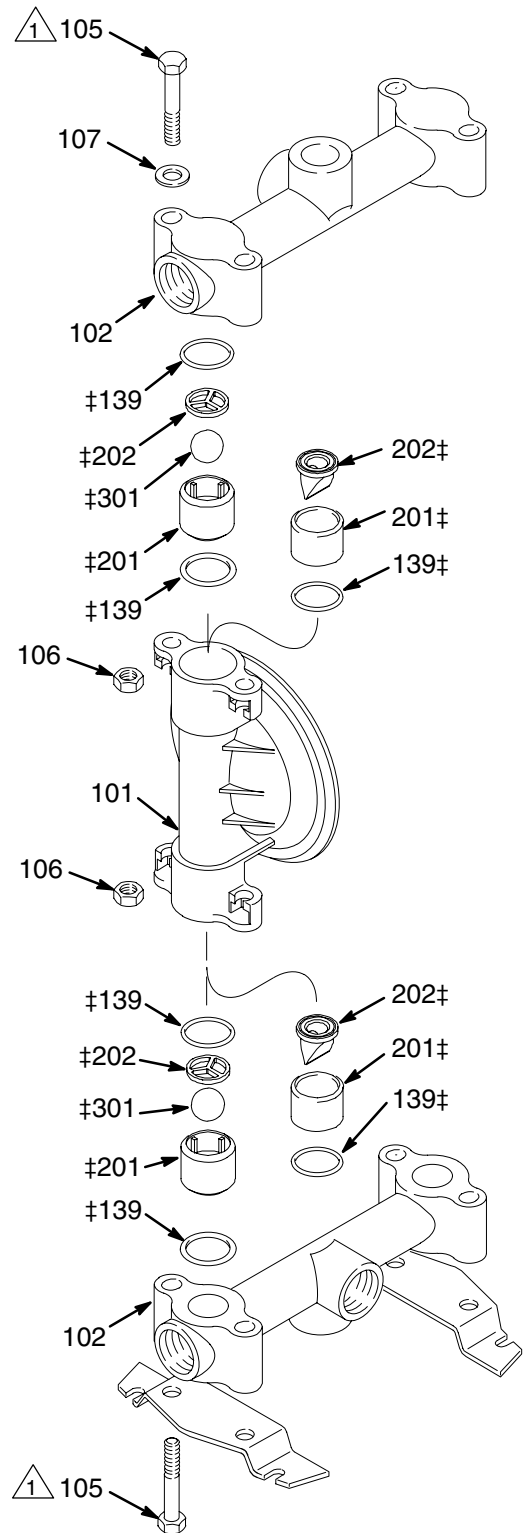

1 Torque to 80 to 90 in-lb (9 to 10 N•m).  
See **Torque Sequence**, page 30.

Fig. 8

9081A

# Service

## Diaphragms (VERDERAIR VA 15)

**NOTE:** Fluid Section Repair Kit is available. See page 23 to order the correct kit for your pump. Parts included in the kit are marked with a double dagger (‡) in Fig. 9 and in the Parts Drawings and Lists. General purpose grease 819.0184 and Adhesive 819.9741 are supplied in the kit. Service the diaphragms as follows. See Fig. 9.

### Disassembly



1. **Relieve the pressure.** See **Pressure Relief Procedure** on page 10.

2. Remove manifolds (102 and 103) and fluid covers (101).

**NOTE:** Make sure all the check valve parts stay in place. See Fig. 7 on page 15.

3. Remove one of the fluid-side diaphragm plates (105) (whichever one comes loose first when you use a wrench on the hex of each), and pull the diaphragm shaft out of the center housing (11).
4. Use a wrench on the flats of the diaphragm shaft (15) to remove the other fluid-side diaphragm plate (105) from the diaphragm shaft.
5. Remove the screws (106), remove the left (114) and right (113) air covers, and remove all old gasket (12) material from the ends of the center housing (11) and the surfaces of the air covers.
6. Remove the diaphragm shaft u-cups (16) and pilot pin o-rings (1).
7. Inspect all parts for wear or damage, and replace as necessary.

### Reassembly

1. Insert a diaphragm shaft u-cup (16) and a pilot pin o-ring (1) into the bores of the center housing (11).

**NOTE:** Make sure the lips of the u-cup face **out** of the center housing.

2. Line up the holes in the gasket (12) with the holes in the end of the center housing (11), and use six screws (106) to fasten an air cover (113 or 114) to the end of the center housing (11). Torque the screws to 35 to 45 in-lb (4.0 to 5.1 N•m).
3. Position the exhaust cover (13) and o-ring (4) on the center housing (11).
4. Repeat steps 1 and 2 for the other end of the center housing and the remaining air cover.
5. Apply medium-strength (blue) Loctite or equivalent to the threads of the fluid-side diaphragm plates (105). Install on one end of the diaphragm shaft (15) the following parts (see proper order in Fig. 9): air-side diaphragm plate (6) diaphragm (401), and fluid-side diaphragm plate (105).  
**NOTE:** The words "AIR SIDE" on the diaphragm (401) and the flat side of the air-side diaphragm plate (6) must face toward the diaphragm shaft (15).
6. Put grease on the diaphragm shaft (15), and carefully (do not damage the shaft u-cups) run the diaphragm shaft (15) through the center housing (11) bore.
7. Repeat step 5 for the other end of the diaphragm shaft (15), and torque the fluid-side diaphragm plates (105) to 80 to 90 in-lb (9 to 10 N•m) at 100 rpm maximum.
8. Install the muffler (3).
9. Make sure all the check valve parts are in place. See Fig. 7 on page 15.
10. Reinstall the fluid covers (101) and manifolds (102 and 103), and torque the fluid cover and manifold nuts (109) to 80 to 90 in-lb (9 to 10 N•m). See **Torque Sequence**, page 30.



# Service

## Diaphragms (VERDERAIR VA 15)

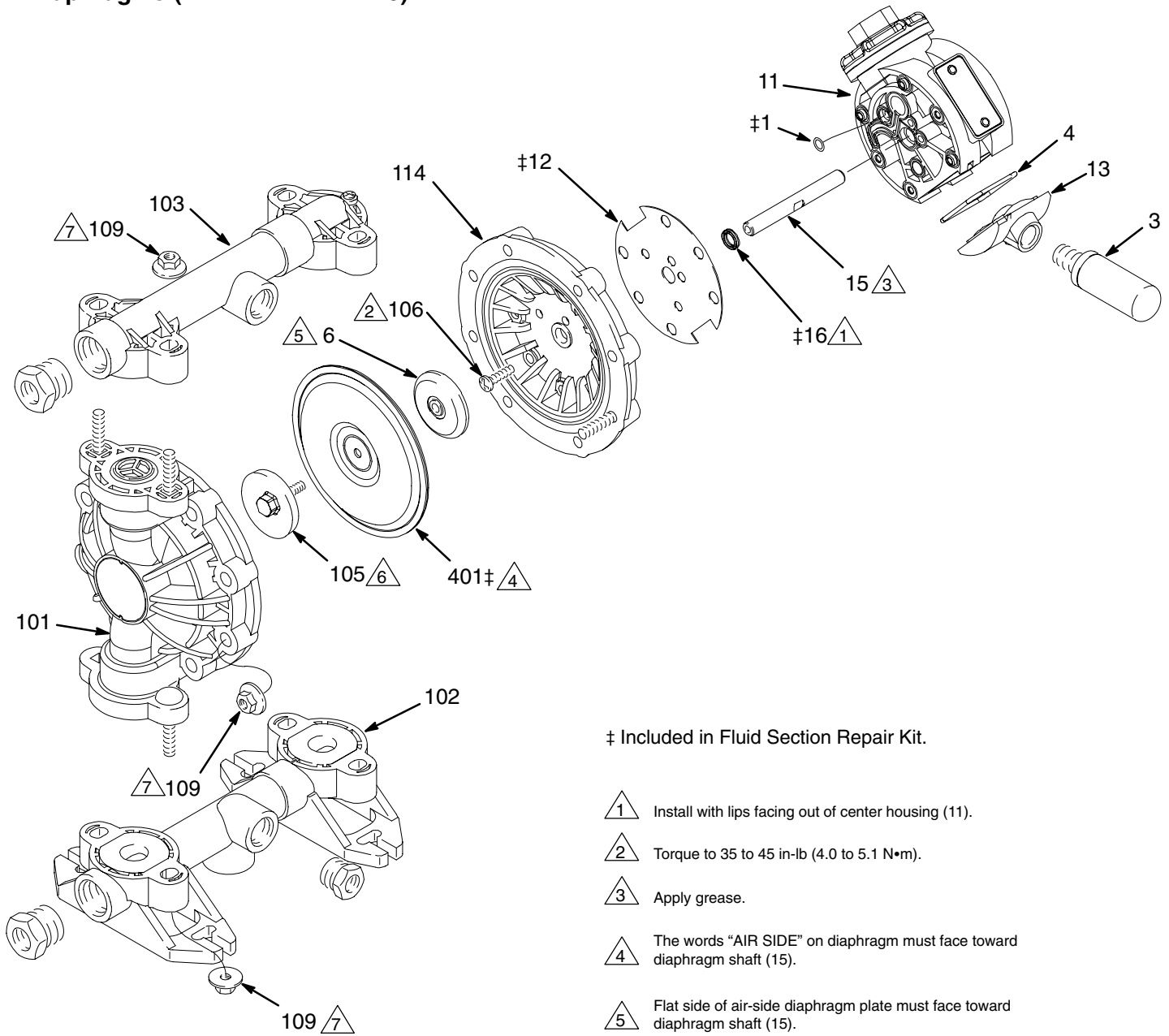

‡ Included in Fluid Section Repair Kit.

- 1 Install with lips facing out of center housing (11).
- 2 Torque to 35 to 45 in-lb (4.0 to 5.1 N•m).
- 3 Apply grease.
- 4 The words "AIR SIDE" on diaphragm must face toward diaphragm shaft (15).
- 5 Flat side of air-side diaphragm plate must face toward diaphragm shaft (15).
- 6 Apply medium-strength (blue) Loctite® or equivalent to threads, and torque to 80 to 90 in-lb (9 to 10 N•m) at 100 rpm maximum.
- 7 Torque to 80 to 90 in-lb (9 to 10 N•m). See **Torque Sequence**, page 30.

Fig. 9

9066A

# Service

## Diaphragms (VERDERAIR VA 20)

**NOTE:** Fluid Section Repair Kit is available. See page 23 to order the correct kit for your pump. Parts included in the kit are marked with a double dagger (‡) in Fig. 10 and in the Parts Drawings and Lists. General purpose grease 819.0184 and Adhesive 819.9741 are supplied in the kit. Service the diaphragms as follows. See Fig. 10.

### Disassembly



1. **Relieve the pressure.** See **Pressure Relief Procedure** on page 10.

2. Remove the manifolds (102) and fluid covers (101).

**NOTE:** Make sure all the check valve parts stay in place. See Fig. 8 on page 15.

3. Remove the grounding strip from the vee clamps (109), and remove the vee clamps.
4. Remove one of the fluid-side diaphragm plates (133) (whichever one comes loose first when you use a wrench on the hex of each), and pull the diaphragm shaft out of the center housing (11).
5. Use a wrench on the flats of the diaphragm shaft (15) to remove the other fluid-side diaphragm plate (133) from the diaphragm shaft.
6. Remove the screws (141) and air covers (136), and remove all old gasket (12) material from the ends of the center housing (11) and the surfaces of the air covers.
7. Remove the diaphragm shaft u-cups (16) and pilot pin o-rings (1).
8. Inspect all parts for wear or damage, and replace as necessary.

### Reassembly

1. Insert a diaphragm shaft u-cup (16) and a pilot pin o-ring (1) into the end of the diaphragm shaft bore of the center housing (11).  
**NOTE:** Make sure the lips of the u-cup face **out** of the center housing.
2. Line up the holes in the gasket (12) with the holes in the end of the center housing (11), and use six screws (141) to fasten an air cover (136) to the end of the center housing (11). Torque the screws to 35 to 45 in-lb (4.0 to 5.1 N•m).

3. Position the exhaust cover (13) and o-ring (4) on the center housing (11).

4. Repeat steps 1 and 2 for the other end of the center housing and the remaining air cover.

5. Apply medium-strength (blue) Loctite or equivalent to the threads of the screws (140). Install on one end of the diaphragm shaft (15) the following parts (see proper order in Fig. 10): air-side diaphragm plate (6), diaphragm (401), fluid-side diaphragm plate (133), o-ring (115), and screw (140).

**NOTE:** The words "AIR SIDE" on the diaphragm (401) and the flat side of the air-side diaphragm plate (6) must face toward the diaphragm shaft (15).

6. Put grease on the diaphragm shaft (15), and carefully (do not damage the shaft u-cups) run the diaphragm shaft (15) through the center housing (11) bore.
7. Repeat step 5 for the other end of the diaphragm shaft (15), and torque the diaphragm shaft screws (140) to 80 to 90 in-lb (9 to 10 N•m) at 100 rpm maximum.
8. Install the muffler (3).

When you install the vee clamps in step 9, orient the center housing (11) so the air inlet is approximately 45° above horizontal and the muffler (3) is approximately horizontal.

9. Apply thin film of grease to inside of vee clamps (109).

10. Position the fluid covers (101), install the vee clamps (109) around the fluid and air covers, install the grounding strip on the vee clamps, and torque the vee clamp nuts to 80 to 90 in-lb (9 to 10 N•m). See **Torque Sequence**, page 30.

11. Make sure all the check valve parts are in place. See Fig. 8 on page 15.

12. Install the manifolds (102), and torque the manifold bolts (105) to 80 to 90 in-lb (9 to 10 N•m). See **Torque Sequence**, page 30.

# Service

## Diaphragms (VERDERAIR VA 20)

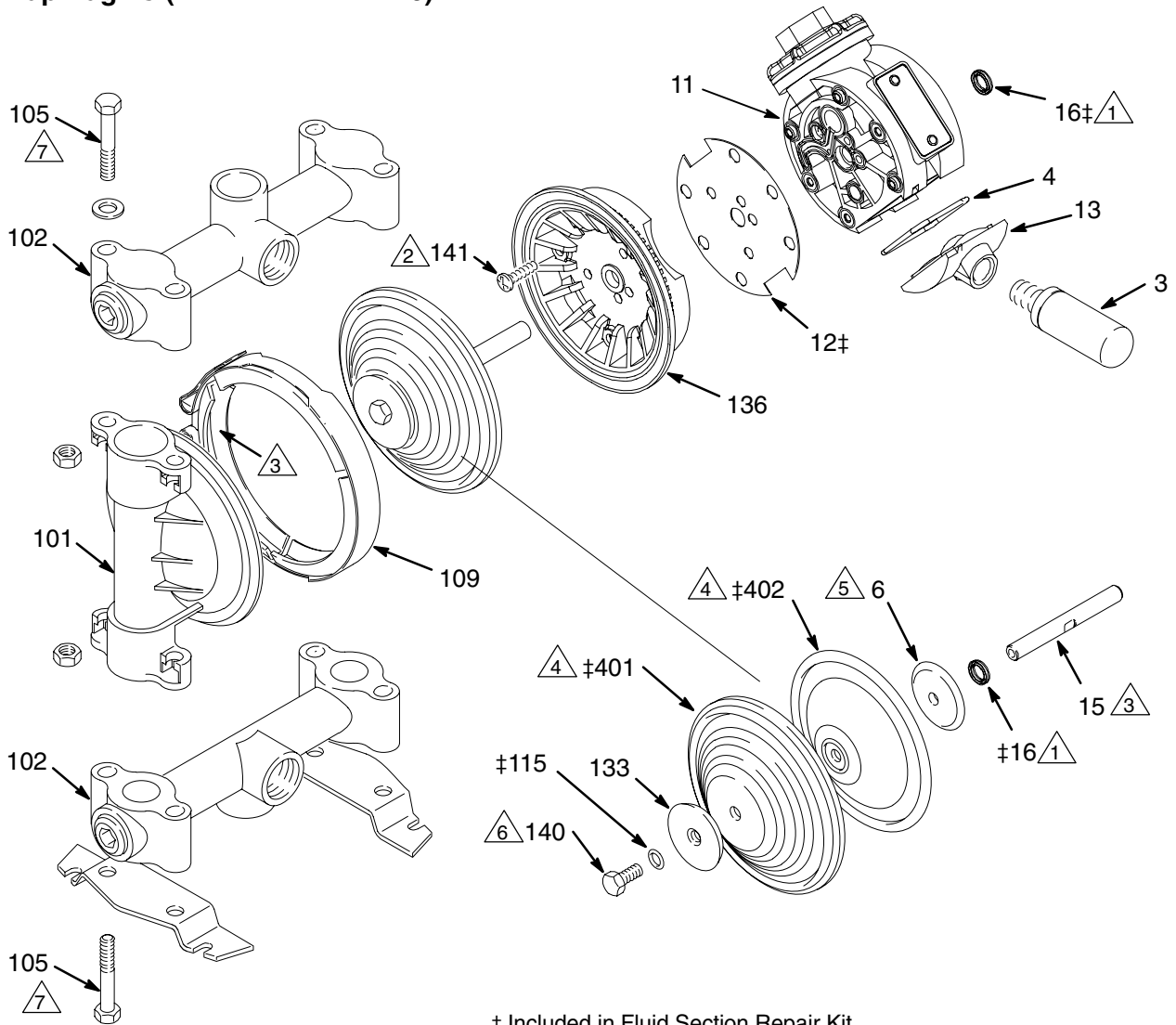

‡ Included in Fluid Section Repair Kit.

- 1 Install with lips facing out of center housing (11).
- 2 Torque to 35 to 45 in-lb (4.0 to 5.1 N•m).
- 3 Apply grease.
- 4 The words "AIR SIDE" on diaphragm and backup diaphragm must face toward diaphragm shaft (15).
- 5 Flat side of the air-side diaphragm plate must face toward diaphragm shaft (15).
- 6 Apply medium-strength (blue) Loctite® or equivalent to threads, and torque to 80 to 90 in-lb (9 to 10 N•m) at 100 rpm maximum.
- 7 Torque to 80 to 90 in-lb (9 to 10 N•m). See **Torque Sequence**, page 30.

Fig. 10

9072A

# VERDERAIR VA 15 Pump Listing

Your Model No. is marked on the pump's serial plate. See the listing of existing *VERDERAIR VA 15* pumps below:

## VA 15 Standard Air Valve

Ref. No.	Fluid Section	Seats and Guides	Checks	Diaphragms
810.6771	AC	AC	TF	TF
810.6758	AC	AC	SS	TF
810.6759	AC	AC	TPE	TPE
810.6760	AC	AC	SP	SP
810.6761	AC	AC	BN	TPE
810.6762	AC	AC	BN	BN
810.6763	AC	SS	TF	TF
810.6764	AC	SS	SS	TF
810.6765	AC	PP	TF	TF
810.6766	AC	PP	BN	BN
810.6767	PP	AC	TF	TF
810.6768	PP	AC	BN	BN
810.6769	PP	SS	TF	TF
810.6770	PP	SS	SS	TF
810.6783	PP	SS	SS	SP
810.6772	PP	PP	TF	TF
810.6773	PP	PP	TF	TPE
810.6774	PP	PP	TF	SP
810.6775	PP	PP	TF	FE
810.6776	PP	PP	SS	TF
810.6777	PP	PP	SS	BN
810.6778	PP	PP	TPE	TPE
810.6779	PP	PP	SP	TF
810.6780	PP	PP	SP	SP
810.6781	PP	PP	BN	BN
810.6782	PP	PP	FE	FE

Ref. No.	Fluid Section	Seats and Guides	Checks	Diaphragms
810.6784	KY	KY	TF	TF
810.6785	KY	KY	FE	FE
810.0181*	PP	PP	SP	SP
810.6848†	PP	PP	SP	SP
810.6849†	PP	PP	TF	TF
810.6850†	KY	KY	TF	SP
810.0401	CPP	AC	TF	TF
810.0402	CPP	AC	BN	BN
810.0403	CPP	SS	TF	TF
810.0404	CPP	SS	SS	TF
810.0405	CPP	SS	SS	SP
810.0406	CPP	PP	TF	TF
810.0407	CPP	PP	TF	TPE
810.0408	CPP	PP	TF	SP
810.0409	CPP	PP	TF	FE
810.0410	CPP	PP	SS	TF
810.0411	CPP	PP	SS	TPE
810.0412	CPP	PP	SS	BN
810.0413	CPP	PP	TPE	TPE
810.0414	CPP	PP	SP	TF
810.0415	CPP	PP	SP	SP
810.0416	CPP	PP	BN	BN
810.0418	CPP	PP	FE	FE
810.0384†	CPP	PP	SP	SP
810.0383†	CPP	PP	TF	TF

AL = Aluminium AC = Acetal BN = Buna-N TPE = Thermoplastic Polyester Elastomer PP = Polypropylene SP = Santoprene  
SS = Stainless Steel TF = PTFE FE = Fluoroelastomer CPP = Conductive Polypropylene

\* 810.0181 is a Split Manifold Pump.

† 810.6848, 810.6849, and 810.6850 have npt threads.

# VERDERAIR VA 15 Pump Listing

Your Model No. is marked on the pump's serial plate. See the listing of existing *VERDERAIR VA 15* pumps below:

## VA 15 for Solenoid Operation

Ref. No.	Fluid Section	Seats and Guides	Checks	Diaphragms
810.6882	AC	AC	TF	TF
810.6881	AC	AC	SS	TF
810.6883	AC	AC	TPE	TPE
810.6884	AC	AC	SP	SP
810.6885	AC	AC	BN	TPE
810.6886	AC	AC	BN	BN
810.6887	AC	SS	TF	TF
810.6888	AC	SS	SS	TF
810.6889	AC	PP	TF	TF
810.6890	AC	PP	BN	BN
810.6891	PP	AC	TF	TF
810.6892	PP	AC	BN	BN
810.6893	PP	SS	TF	TF
810.6894	PP	SS	SS	TF
810.6896	PP	PP	TF	TF
810.6897	PP	PP	TF	TPE
810.6898	PP	PP	TF	SP
810.6899	PP	PP	TF	FE
810.6900	PP	PP	SS	TF
810.6901	PP	PP	SS	BN
810.6902	PP	PP	TPE	TPE
810.6903	PP	PP	SP	TF

Ref. No.	Fluid Section	Seats and Guides	Checks	Diaphragms
810.6904	PP	PP	SP	SP
810.6905	PP	PP	BN	BN
810.6906	PP	PP	FE	FE
810.6907	PP	SS	SS	SP
810.6908	KY	KY	TF	TF
810.6909	KY	KY	FE	FE
810.0386	CPP	AC	BN	BN
810.0387	CPP	SS	TF	TF
810.0388	CPP	SS	SS	TF
810.0390	CPP	PP	TF	TF
810.0391	CPP	PP	TF	TPE
810.0392	CPP	PP	TF	SP
810.0393	CPP	PP	TF	FE
810.0394	CPP	PP	SS	TF
810.0395	CPP	PP	SS	BN
810.0396	CPP	PP	TPE	TPE
810.0397	CPP	PP	SP	TF
810.0398	CPP	PP	SP	SP
810.0399	CPP	PP	BN	BN
810.0400	CPP	PP	FE	FE
810.0389	CPP	SS	SS	SP

AL = Aluminium AC = Acetal BN = Buna-N TPE = Thermoplastic Polyester Elastomer PP = Polypropylene SP = Santoprene  
 SS = Stainless Steel TF = PTFE FE = Fluoroelastomer CPP = Conductive Polypropylene

# VERDERAIR VA 20 Pump Listing

Your Model No. is marked on the pump's serial plate. See the listing of existing *VERDERAIR VA 20* pumps below:

## VA 20 Standard Air Valve

Ref. No.	Fluid Section	Seats and Guides	Checks	Diaphragms
810.6815	AL	AC	TF	TF
810.6816	AL	AC	TF	TPE
810.6817	AL	AC	SS	TF
810.6818	AL	AC	TPE	TPE
810.6819	AL	AC	SP	SP
810.6820	AL	AC	BN	BN
810.6821	AL	AC	FE	FE
810.6822	AL	SS	TF	TF
810.6823	AL	SS	TF	TPE
810.6824	AL	SS	SS	TF
810.6825	AL	SS	SS	TPE
810.6826	AL	SS	SS	SP
810.6827	AL	SS	SS	BN
810.6828	AL	SS	SS	FE
810.6829	AL	SS	TPE	TPE
810.6830	AL	SS	SP	SP
810.6831	AL	SS	BN	BN
810.6832	AL	SS	FE	FE
810.6833	AL	PP	TF	TF
810.6834	AL	PP	TPE	TPE
810.6835	AL	PP	SP	SP
810.6836	AL	PP	BN	BN
810.6837	SS	AC	TF	TF
810.6838	SS	AC	SS	TF
810.6839	SS	SS	TF	TF
810.6840	SS	SS	SS	TF
810.6841	SS	SS	SS	TPE
810.6842	SS	SS	SS	SP
810.6843	SS	SS	BN	BN
810.6844	SS	SS	FE	TF
810.6845	SS	SS	FE	FE
810.6846	SS	PP	TF	TF
810.6847	AL	AC	SS	BN
810.6852†	AL	PP	SP	SP
810.6853†	AL	SS	BN	BN
810.6854†	AL	SS	TF	TF
810.6855†	SS	SS	TF	TF

## VA 20 for Solenoid Operation

Ref. No.	Fluid Section	Seats and Guides	Checks	Diaphragms
810.6939	AL	AC	TF	TF
810.6940	AL	AC	TF	TPE
810.6941	AL	AC	SS	TF
810.6942	AL	AC	TPE	TPE
810.6943	AL	AC	SP	SP
810.6944	AL	AC	BN	BN
810.6945	AL	AC	FE	FE
810.6946	AL	SS	TF	TF
810.6947	AL	SS	TF	TPE
810.6948	AL	SS	SS	TF
810.6949	AL	SS	SS	TPE
810.6950	AL	SS	SS	SP
810.6951	AL	SS	SS	BN
810.6952	AL	SS	SS	FE
810.6953	AL	SS	TPE	TPE
810.6954	AL	SS	SP	SP
810.6955	AL	SS	BN	BN
810.6956	AL	SS	FE	FE
810.6957	AL	PP	TF	TF
810.6958	AL	PP	TPE	TPE
810.6959	AL	PP	SP	SP
810.6960	AL	PP	BN	BN
810.6961	SS	AC	TF	TF
810.6962	SS	AC	SS	TF
810.6963	SS	SS	TF	TF
810.6964	SS	SS	SS	TF
810.6965	SS	SS	SS	TPE
810.6966	SS	SS	SS	SP
810.6967	SS	SS	BN	BN
810.6968	SS	SS	FE	TF
810.6969	SS	SS	FE	FE
810.6970	SS	PP	TF	TF
810.6971	AL	AC	SS	BN

AL = Aluminium AC = Acetal BN = Buna-N TPE = Thermoplastic Polyester Elastomer PP = Polypropylene SP = Santoprene  
SS = Stainless Steel TF = PTFE FE = Fluoroelastomer

† 810.6852, 810.6853, 810.6854, and 810.6855 have npt threads.

# VERDERAIR VA 15 and VERDERAIR VA 20 Repair Kits

**NOTE:** Order Repair Kits separately.

To order the Air Valve Repair Kit, order **Part No. 819.9740**.

Ref. No.	Seats and Guides	Checks	Diaphragms
819.5183	PP	FE	FE
819.5176	PP	BN	BN
819.5172	PP	BN	—
819.5169	PP	SP	SP
819.5162	PP	TPE	TPE
819.5149	PP	TF	TF
819.5148	PP	TF	—
819.5135	SS	FE	FE
819.5130	SS	FE	—
819.5128	SS	BN	BN
819.5124	SS	BN	—
819.5107	SS	SS	TF
819.5101	SS	TF	TF
819.5100	SS	TF	—
819.5080	AC	BN	BN
819.5076	AC	BN	—
819.5066	AC	TPE	TPE
819.5059	AC	SS	TF
819.5054	AC	TF	TPE
8195053	AC	TF	TF
819.5052	AC	TF	—
819.5010	SS	Checks	
819.5003	FE	Diaphragms	
819.5002	BN	Diaphragms	
819.5001	SP	Diaphragms	
819.4999	TF	Diaphragms	
819.5121	SS	SP	SP

AL = Aluminium AC = Acetal BN = Buna-N TPE = Thermoplastic Polyester Elastomer PP = Polypropylene SP = Santoprene  
SS = Stainless Steel TF = PTFE FE = Fluoroelastomer

## Proximity Sensor Accessory Kits for VA15 Pumps Only

Kit	Description
819.6992	<b>Sensor</b> Includes 1 each of reed switch and carriage assembly
819.6993	<b>Sensor with Counter</b> Includes 1 each of reed switch, counter, bracket, and carriage assembly

# VERDERAIR VA 15 and VERDERAIR VA 20

## Common Parts

### Air Motor Parts List

Ref. No.	Part No.	Description	Qty
1†	819.6909	PACKING, o-ring	2
2†	819.6910	PACKING, u-cup	2
3	819.6351	MUFFLER	1
4†	819.6584	PACKING, o-ring	2
6	819.6911	PLATE, diaphragm, air side	2
7†	819.6912	PLUNGER, carriage	2
8†	819.6913	CARRIAGE	2
8**	819.0240	CARRIAGE with magnet	—
9†	819.6914	PIN, carriage	2
10	819.6915	COVER, valve chamber	1
11	819.6916	HOUSING, center	1
11*	819.9744	HOUSING, center	1
12†	819.6917	GASKET	2
13	819.6918	COVER, exhaust	1
14†	819.6919	PLATE, valve	1
15	819.6920	SHAFT, diaphragm	1
16*	819.7068	CONNECTOR, male	2
17*	819.9746	PIN	2

\* These parts are unique to the remote piloted air motor.

\*\* This part comes with the proximity sensor accessory. The pump includes standard carriages, without magnet.

### Guide Parts List

Ref. No.	Part No.	Description	Qty
201†	819.4440	GUIDE; acetal	4
202†	819.4441	STOP; acetal	4
201†	819.4442	GUIDE; sst	4
202†	819.4443	STOP; sst	4
201†	819.4444	GUIDE; polypropylene	4
202†	819.4445	STOP; polypropylene	4
201†	819.6925	GUIDE; PVDF	4
202†	819.6926	STOP; PVDF	4
201†	819.6927	SPACER	4
202†	819.6928	VALVE, duckbill	4

### Ball Parts List

Digit	Ref. No.	Part No.	Description	Qty
1	301†	819.4446	BALL; PTFE	4
3	301†	819.4447	BALL; sst	4
5	301†	819.4448	BALL; TPE	4
6	301†	819.4449	BALL; Santoprene®	4
7	301†	819.4450	BALL; buna-N	4
8	301†	819.4415	BALL; fluoroelastomer	4

### Diaphragm Parts List

Diaphragm Material	Ref. No.	Part No.	Description	Qty
PTFE	16†	819.6910	PACKING, u-cup	2
	401†	819.4453	DIAPHRAGM; PTFE	2
	402†	819.4452	DIAPHRAGM, backup; polyurethane	2
TPE	16†	819.6910	PACKING, u-cup	2
	401†	819.4454	DIAPHRAGM; TPE	2
SANTO-PRENE	16†	819.6910	PACKING, u-cup	2
	401†	819.4414	DIAPHRAGM; Santoprene®	2
BUNA-N	16†	819.6910	PACKING, u-cup	2
	401†	819.4455	DIAPHRAGM; buna-N	2
FLUORO-ELASTOMER	16†	819.6910	PACKING, u-cup	2
	401†	819.4416	DIAPHRAGM; fluoroelastomer	2

† Included in Air Valve Repair Kit 819.9740.

‡ Included in Fluid Section Repair Kit.



# VERDERAIR VA 15 Parts Drawing

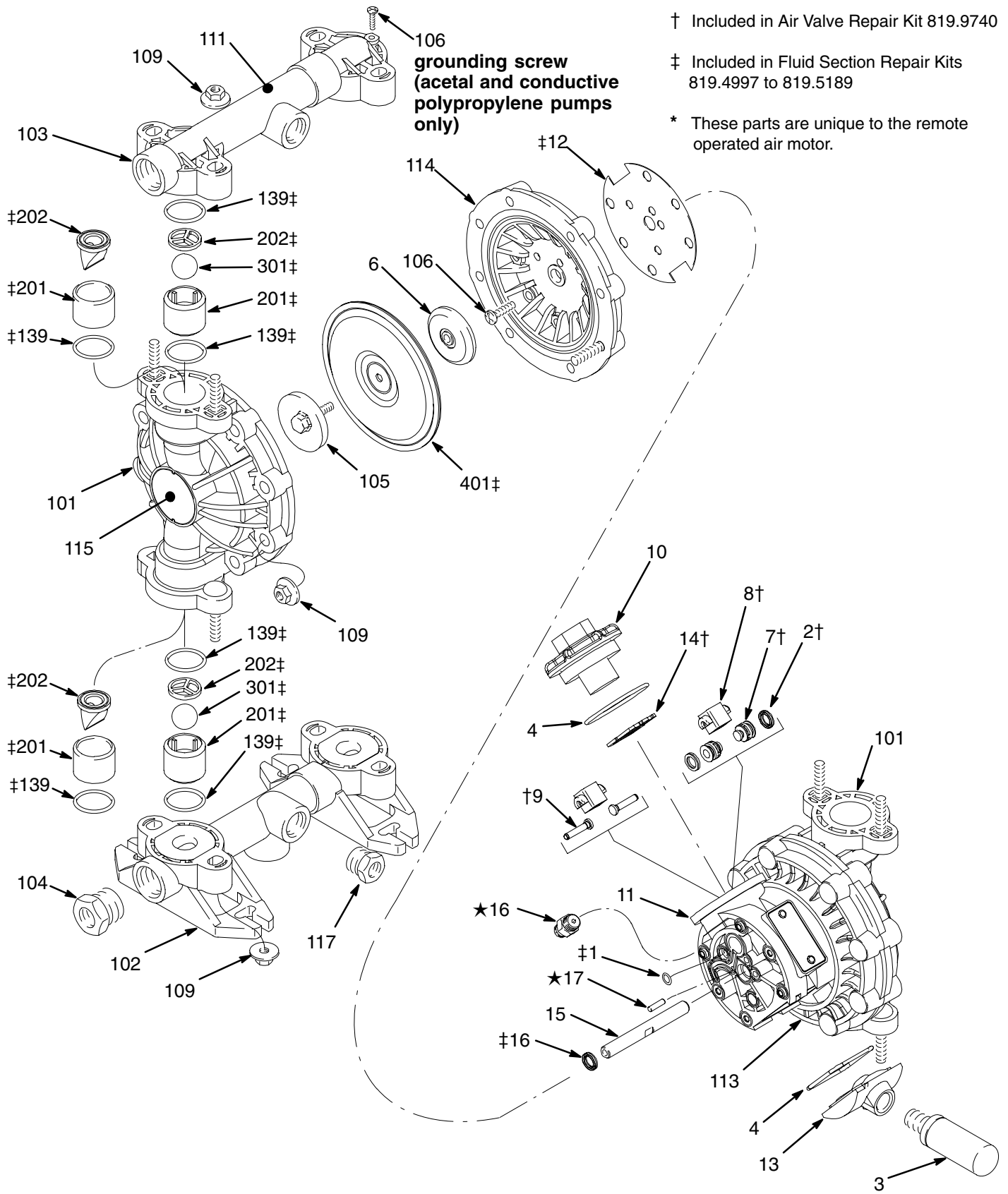

9064A

# VERDERAIR VA 15 Fluid Section Parts List

See page 24 for Air Motor Parts List

## VERDERAIR VA 15 Polypropylene and Conductive Polypropylene Fluid Section Parts List

Ref. No.	Polypropylene Pumps			Conductive Polypropylene Pumps		
	Part No.	Description	Qty	Part No.	Description	Qty
101	819.6945	COVER, fluid; polypropylene	2	819.0260	COVER, fluid; conductive polypropylene	2
102	819.6947	MANIFOLD, inlet; polypropylene; BSPT	1	819.0264	MANIFOLD, inlet; conductive polypropylene; BSPT	1
	819.0054	MANIFOLD, split, inlet; polypropylene; BSPT (For 810.0181 only)	2			
	819.7155	MANIFOLD, inlet; polypropylene; npt (For 810.6848 and 810.6849 only)	1			
103	819.6949	MANIFOLD, outlet; polypropylene; BSPT	1	819.0263	MANIFOLD, outlet; conductive polypropylene; BSPT	1
	819.0053	MANIFOLD, split, outlet; polypropylene; BSPT (For 810.0181 only)	2			
	819.7156	MANIFOLD, outlet; polypropylene; npt (For 810.6848 and 810.6849 only)	1			
104	819.6951	PLUG; polypropylene; 3/4 BSPT	2	819.6951	PLUG; polypropylene; 3/4 BSPT	2
	819.7158	PLUG; polypropylene; 3/4 npt (For 810.6848 and 810.6849 only)	2	819.7158	PLUG; polypropylene; 3/4 npt (For 810.6848 and 810.6849 only)	2
105	819.0202	PLATE, diaphragm, fluid; polypropylene	2	819.0202	PLATE, diaphragm, fluid; polypropylene	2
106	819.6936	SCREW, mach.	12	819.6936	SCREW, mach.	13
109	819.6937	NUT, hex, large flng	24	819.6937	NUT, hex, large flng	24
111	819.0195	LABEL, warning	1	819.0195	LABEL, warning	1
113	819.6938	COVER, air, right	1	819.6938	COVER, air, right	1
114	819.6939	COVER, air, left	1	819.6939	COVER, air, left	1
117	819.6953	PLUG; polypropylene; 1/2 BSPT	2	819.6953	PLUG; polypropylene; 1/2 BSPT	2
	819.7157	PLUG; polypropylene; 1/2 npt (For 810.6848 and 810.6849 only)	2	819.7157	PLUG; polypropylene; 1/2 npt (For 810.6848 and 810.6849 only)	2
119	819.6943	RIVET (for plate 116)	2	819.6943	RIVET (for plate 116)	2
139‡	819.6944	PACKING, o-ring; encapsulated	8	819.6944	PACKING, o-ring; encapsulated	8

# VERDERAIR VA 15 Fluid Section Parts List

See page 24 for Air Motor Parts List

## VERDERAIR VA 15 Acetal and PVDF Fluid Section Parts List

Ref. No.	Acetal Pumps			PVDF Pumps		
	Part No.	Description	Qty	Part No.	Description	Qty
101	819.6929	COVER, fluid; acetal	2	819.6954	COVER, fluid; PVDF	2
102	819.6931	MANIFOLD, inlet; acetal; BSPT	1	819.6956	MANIFOLD, inlet; PVDF; BSPT	1
				819.6955	MANIFOLD, inlet; PVDF; npt (For 810.6850 only)	1
103	819.6933	MANIFOLD, outlet; acetal; BSPT	1	819.6958	MANIFOLD, outlet; PVDF; BSPT	1
				819.6957	MANIFOLD, outlet; PVDF; npt (For 810.6850 only)	1
104	819.6935	PLUG; acetal; 3/4 BSPT	2	819.6960	PLUG; PVDF; 3/4 BSPT	2
				819.7154	PLUG; PVDF, 3/4 npt (For 810.6850 only)	2
105	819.0190	PLATE, diaphragm, fluid; acetal	2	819.6961	PLATE, diaphragm, fluid; PVDF	2
106	819.6936	SCREW, mach.	13	819.6936	SCREW, mach.	12
109	819.6937	NUT, hex, large flng	24	819.6937	NUT, hex, large flng	24
111	819.0195	LABEL, warning	1	819.0195	LABEL, warning	1
113	819.6938	COVER, air, right	1	819.6938	COVER, air, right	1
114	819.6939	COVER, air, left	1	819.6939	COVER, air, left	1
117	819.6942	PLUG, acetal; 1/2 BSPT	2	819.6963	PLUG; PVDF; 1/2 BSPT	2
				819.7153	PLUG; PVDF; 1/2 npt (For 810.6850 only)	2
119	819.6943	RIVET (for plate 116)	2	819.6943	RIVET (for plate 116)	2
139‡	819.6944	PACKING, o-ring; encapsulated	8	819.6944	PACKING, o-ring; encapsulated	8

# VERDERAIR VA 20 Parts Drawing

† Included in Air Valve Repair Kit 819.9740

‡ Included in Fluid Section Repair Kits 819.4997 to 819.5189

\* These parts are unique to the remote operated air motor.

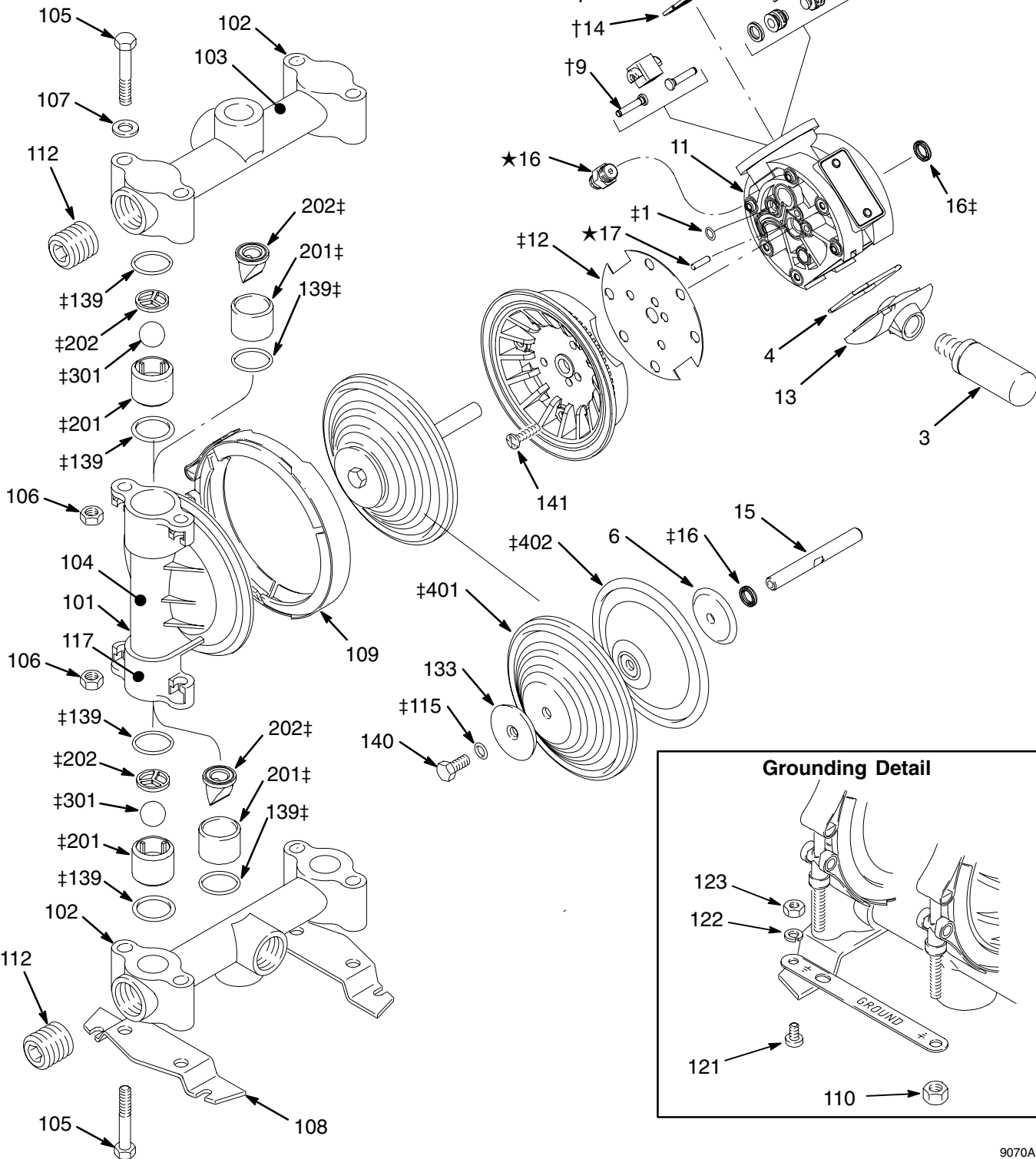

9070A

# VERDERAIR VA 20 Fluid Section Parts List

See page 24 for Air Motor Parts List

## VERDERAIR VA 20 Fluid Section Parts List

Ref. No.	Aluminum Pumps			Stainless Steel (sst) Pumps		
	Part No.	Description	Qty	Part No.	Description	Qty
101	819.4457	COVER, fluid; aluminum	2	819.4467	COVER, fluid; sst	2
102	819.6964	MANIFOLD; aluminum; BSPT	2	819.6970	MANIFOLD; sst; BSPT	2
	819.4458	MANIFOLD; aluminum; NPT (for 810.6852, 810.6853, and 810.6854 only)	2	819.4468	MANIFOLD; sst; NPT (for 810.6855 only)	2
103	819.4434	LABEL, warning	1	819.4434	LABEL, warning	1
104	819.6965	LABEL, identification	1	819.6965	LABEL, identification	1
105	819.4459	SCREW; 3/8–16; 2.25 in. (57.2 mm)	8	819.4459	SCREW; 3/8–16; 2.25 in. (57.2 mm)	8
106	819.4460	NUT, hex; 3/8–16; sst	8	819.4460	NUT, hex; 3/8–16; sst	8
107	819.4461	WASHER, flat; 3/8 in.; sst	4	819.4461	WASHER, flat; 3/8 in.; sst	4
108	819.4462	BASE, feet	2	819.4462	BASE, feet	2
109	819.4433	CLAMP, vee	2	819.4433	CLAMP, vee	2
110	819.0198	NUT, clamp; 1/4–28	2	819.0198	NUT, clamp; 1/4–28	2
111	819.6354	STRIP, grounding	1	819.6354	STRIP, grounding	1
112	819.6967	PLUG, steel; BSPT	2	819.6971	PLUG; sst; BSPT	2
	819.4463	PLUG, steel; NPT (for 810.6852, 810.6853, and 810.6854 only)	2	819.4469	PLUG; sst; NPT (for 810.6855 only)	2
115‡	819.6557	O-RING; PTFE	2	819.6557	O-RING; PTFE	2
117	819.4466	LABEL, warning	1			
121	819.6880	SCREW; 10–24; 0.31 in. (8 mm)	1	819.6880	SCREW; 10–24; 0.31 in. (8 mm)	1
122	819.0187	LOCKWASHER; #10	1	819.0187	LOCKWASHER; #10	1
123	819.0185	NUT, hex; 10–24	1	819.0185	NUT, hex; 10–24	1
133	819.6968	PLATE, diaphragm, fluid side; sst	2	819.0356	PLATE, diaphragm, fluid side; sst machined	2
136	819.6969	COVER air	2	819.6969	COVER air	2
139‡	819.4432	O-RING; PTFE	8	819.4432	O-RING; PTFE	8
140	819.6556	SCREW, flange; hex head	2	819.6556	SCREW, flange; hex head	2
141	819.6936	SCREW, machine	12	819.6936	SCREW, machine	12
142	819.6943	RIVET (for plate 134)	2	819.6943	RIVET (for plate 134)	2

‡ Included in Fluid Section Repair Kit.

# Torque Sequence

Always follow torque sequence when instructed to torque fasteners.

## VERDERAIR VA 15

1. Left/Right Fluid Covers  
Torque bolts to 80–90 in-lb (9–10 N•m)

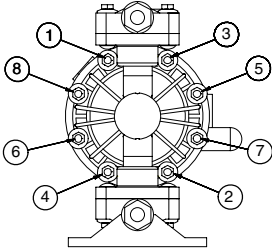

SIDE VIEW

## VERDERAIR VA 20

1. Left/Right Fluid Covers  
Torque bolts to 80–90 in-lb (9–10 N•m)

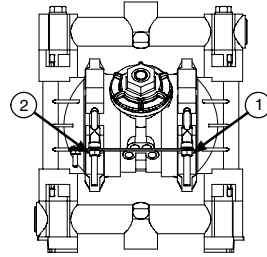

FRONT VIEW

2. Inlet Manifold  
Torque bolts to 80–90 in-lb (9–10 N•m)

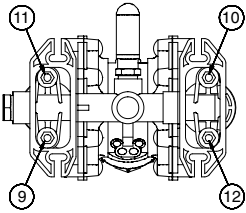

BOTTOM VIEW

2. Inlet Manifold  
Torque bolts to 80–90 in-lb (9–10 N•m)

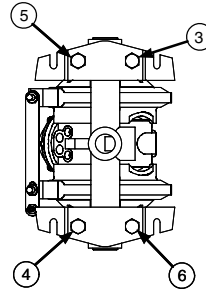

BOTTOM VIEW

3. Outlet Manifold  
Torque bolts to 80–90 in-lb (9–10 N•m)

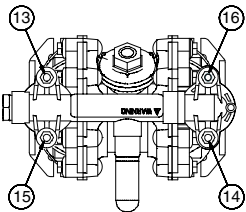

TOP VIEW

3. Outlet Manifold  
Torque Bolts to 80–90 in-lb (9–10 N•m)

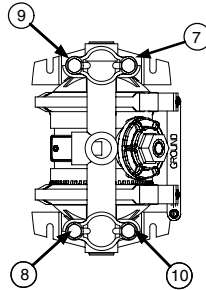

TOP VIEW

# VERDERAIR VA 15 Technical Data

Maximum fluid working pressure .....	100 psi; 0.7 MPa (7 bar)
Air pressure operating range .....	30 to 100 psi; 0.18 to 0.7 MPa (1.8 to 7 bar)
Maximum air consumption .....	28 scfm; 0.793 cubic meters/min.
Maximum free flow delivery .....	15 gpm; 57 l/min.
Maximum pump speed .....	400 cpm
Liters per cycle .....	0.15
Maximum suction lift (water) .....	15 ft; 4.5 m dry, 25 ft; 7.6 m wet
Maximum size pumpable solids .....	3/32 in.; 2.5 mm
Sound power level (measured per ISO standard 9614-2)	
At 70 psig; 0.48 MPa (4.8 bar) at 50 cycles per minute .....	77 dBa
At 100 psig; 0.7 MPa (7 bar) at maximum cycles per minute .....	95 dBa
Sound pressure level (measured 1 meter from pump)	
At 70 psig; 0.48 MPa (4.8 bar) at 50 cycles per minute .....	67 dBa
At 100 psig; 0.7 MPa (7 bar) at maximum cycles per minute .....	85 dBa
Air inlet size .....	1/4 npt(f)
Air exhaust port size .....	3/8 npt(f)
*Fluid inlet size .....	1/2 and 3/4 in. bspt(f)
*Fluid outlet size .....	1/2 and 3/4 in. bspt(f)
Wetted parts (in addition to ball, seat, and diaphragm materials, which vary by pump)	
Polypropylene pumps .....	polypropylene, PTFE
Conductive polypropylene pumps .....	groundable polypropylene, PTFE
Acetal pumps .....	groundable acetal, PTFE
PVDF pumps .....	PVDF, PTFE
Non-wetted external parts .....	polypropylene, stainless steel, polyester and aluminum (labels), nickel-plated brass
Weight (approximate)	
Polypropylene pumps .....	6.5 lb; 2.9 kg
Acetal pumps .....	7.8 lb; 3.5 kg
PVDF pumps .....	8.5 lb; 3.9 kg

*Santoprene® is a registered trademark of the Monsanto Company.*

*Loctite® is a registered trademark of the Loctite Corporation.*

\* On pumps 810.6848, 810.6849, and 810.6850 the fluid inlet and outlet sizes are 1/2 and 3/4 in. npt (f).

# VERDERAIR VA 15 Dimensions

## FRONT VIEW

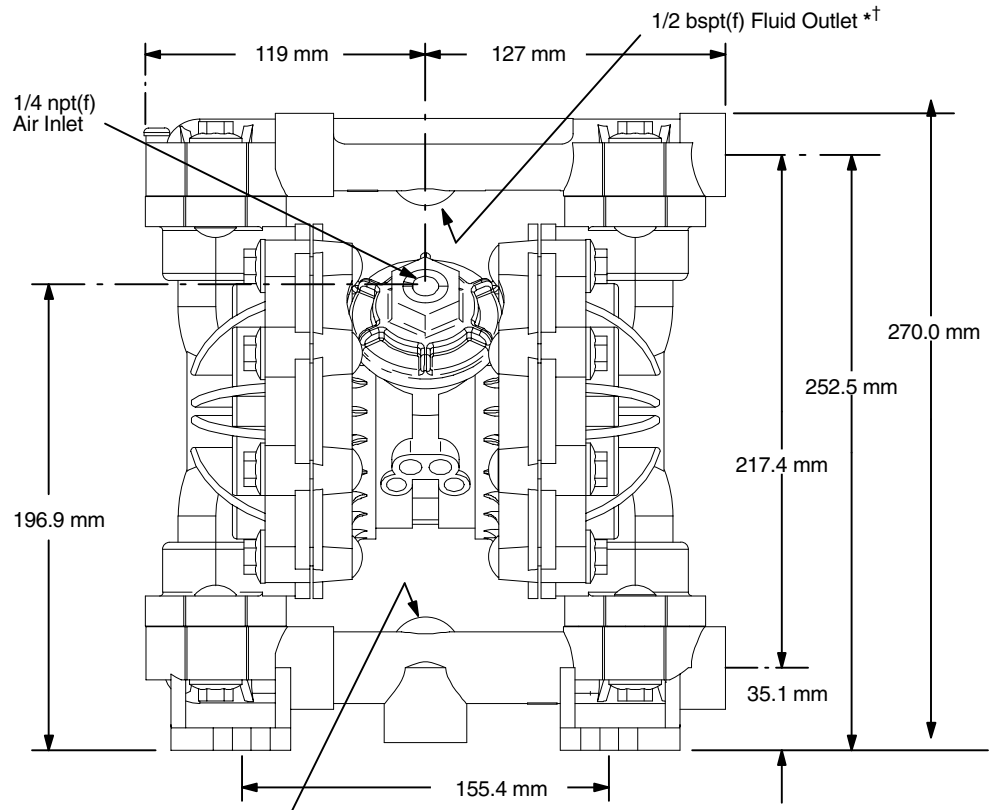

\* Pumps with duckbill check valves are shipped with the inlet manifold on top and the outlet manifold on the bottom. To make the inlet manifold on the bottom and the outlet manifold on the top, rotate each of the four duckbill assemblies vertically 180° as shown below.

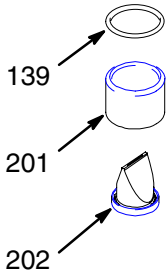

## SIDE VIEW

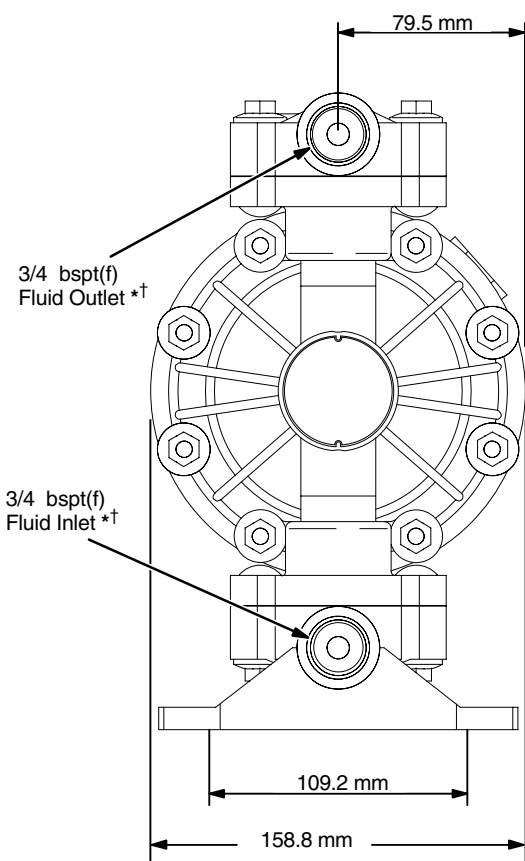

## PUMP MOUNTING HOLE PATTERN

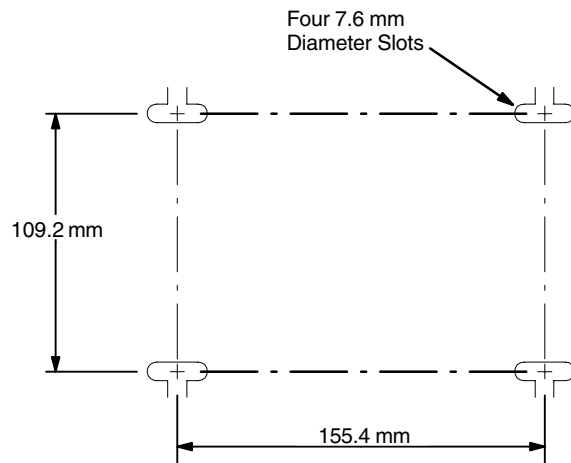

† On pumps 810.6848, 810.6849, and 810.6850 fluid inlets and outlets have npt(f) threads.

9077A



# VERDERAIR VA 20 Technical Data

Maximum fluid working pressure .....	100 psi; 0.7 MPa (7 bar)
Air pressure operating range .....	30 to 100 psi; 0.18 to 0.7 MPa (1.8 to 7 bar)
Maximum air consumption .....	28 scfm; 0.793 cubic meters/min.
Maximum free flow delivery .....	16 gpm; 61 l/min.
Maximum pump speed .....	400 cpm
Liters per cycle .....	0.15
Maximum suction lift (water) .....	15 ft; 4.5 m dry, 25 ft; 7.6 m wet
Maximum size pumpable solids .....	3.32 in.; 2.5 mm
Sound power level (measured per ISO standard 9614-2)	
At 70 psig; 0.48 MPa (4.8 bar) at 50 cycles per minute .....	77 dBa
At 100 psig; 0.7 MPa (7 bar) at maximum cycles per minute .....	95 dBa
Sound pressure level (measured 1 meter from pump)	
At 70 psig; 0.48 MPa (4.8 bar) at 50 cycles per minute .....	67 dBa
At 100 psig; 0.7 MPa (7 bar) at maximum cycles per minute .....	85 dBa
Air inlet size .....	1/4 npt(f)
Air exhaust port size .....	3/8 npt(f)
Fluid inlet size .....	3/4 bspt(f)
819.6852, 819.6853, 819.6854, and 819.6855 only .....	3/4 npt(f)
Fluid outlet size .....	3/4 bspt(f)
819.6852, 819.6853, 819.6854, and 819.6855 only .....	3/4 npt(f)
Wetted parts (in addition to ball, seat, and diaphragm materials, which vary by pump)	
Aluminum pumps .....	aluminum, stainless steel, PTFE, zinc-plated steel
Stainless steel pumps .....	316 stainless steel, PTFE
Non-wetted external parts .....	polypropylene, stainless steel, polyester (labels), nickel-plated brass, epoxy-coated steel (feet)
Weight (approximate)	
Aluminum pumps .....	8.5 lb; 3.9 kg
Stainless steel pumps .....	18 lb; 8.2 kg

*Santoprene® is a registered trademark of the Monsanto Company.*

*Loctite® is a registered trademark of the Loctite Corporation.*

# VERDERAIR VA 20 Dimensions

\* Pumps with duckbill check valves are shipped with the inlet manifold on top and the outlet manifold on the bottom. To make the inlet manifold on the bottom and the outlet manifold on the top, rotate each of the four duckbill assemblies vertically 180° as shown below.

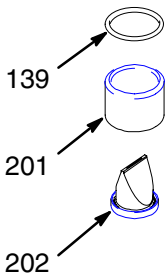

## FRONT VIEW

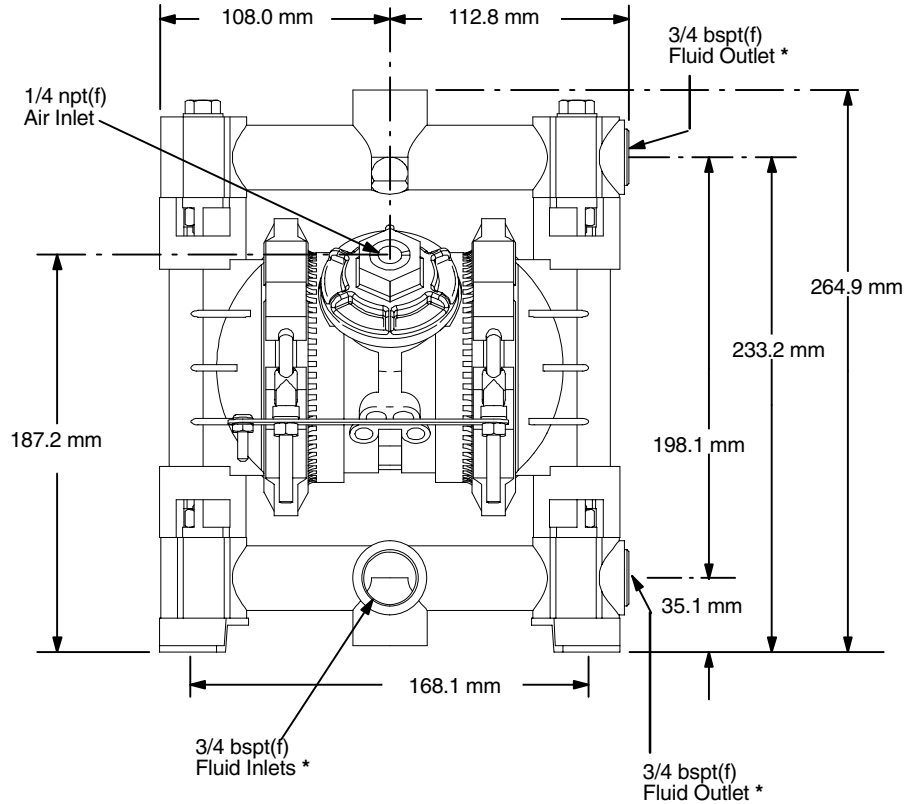

## SIDE VIEW

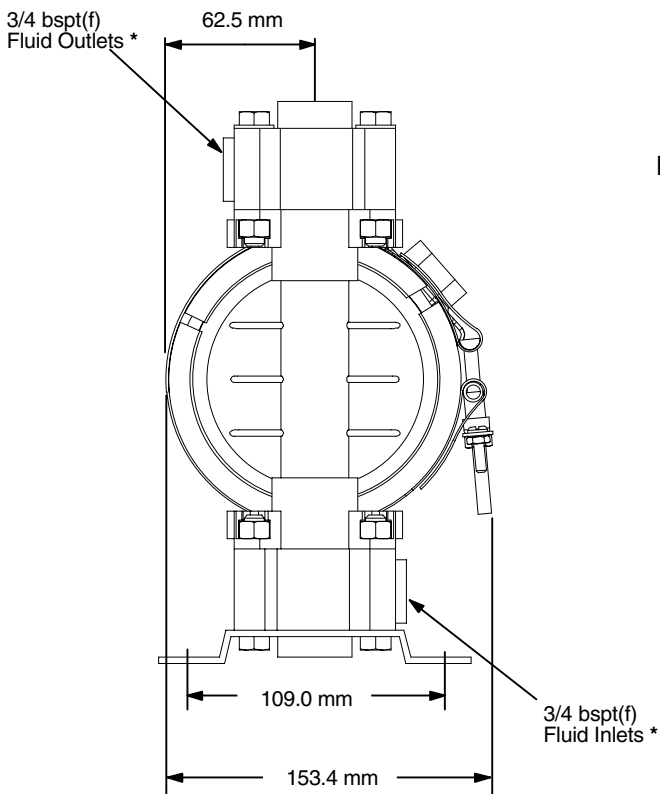

## PUMP MOUNTING HOLE PATTERN

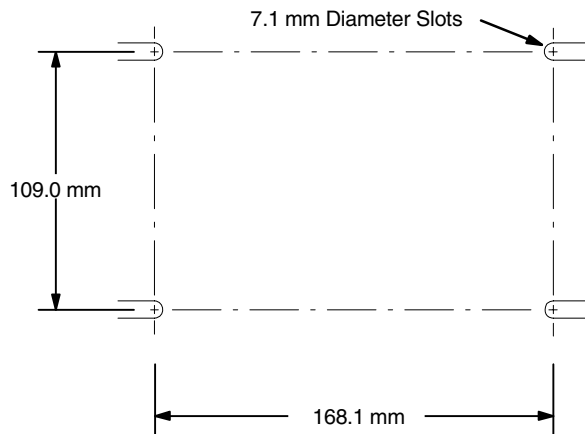

9078A

# VERDERAIR VA 15 and VA 20 Performance Charts

## Fluid Outlet Pressure

**Test Conditions:** Pump tested in water with inlet submerged.

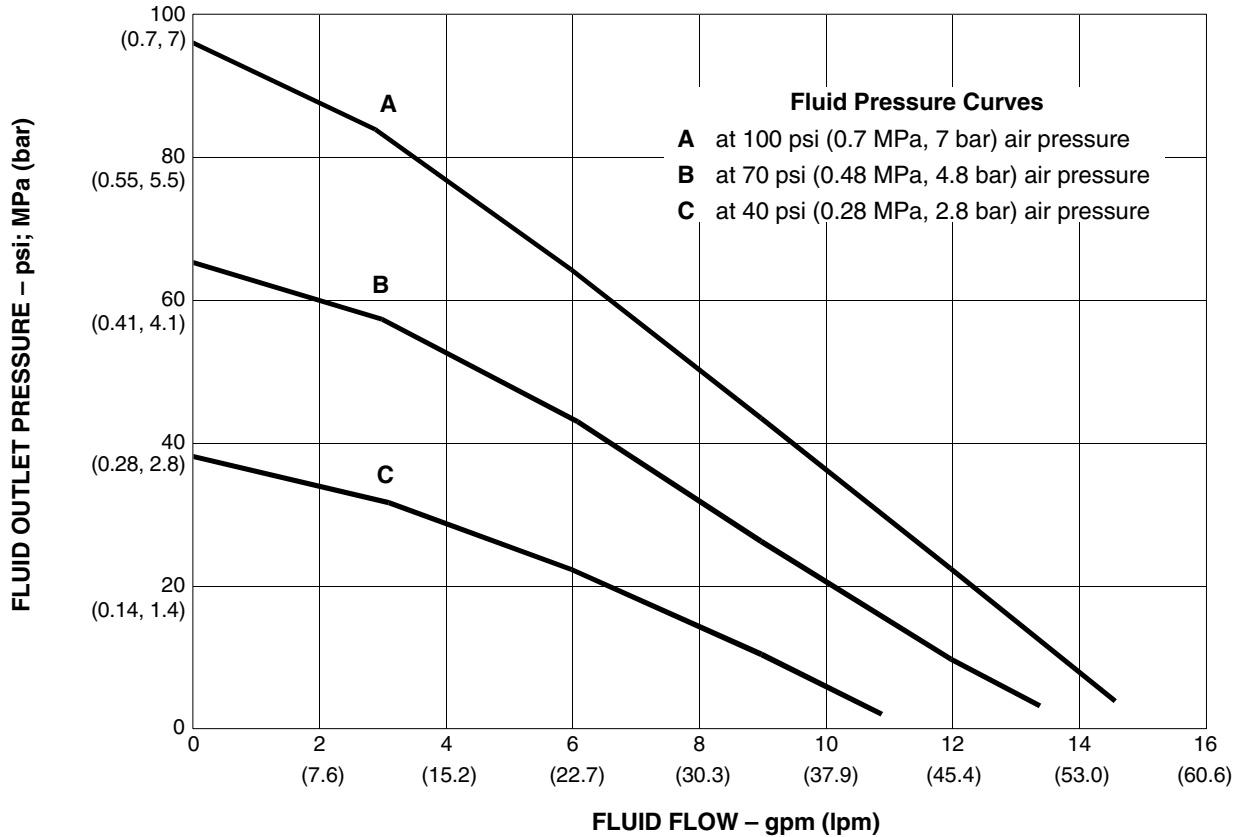

**To find Fluid Outlet Pressure (psi/MPa/bar) at a specific fluid flow (gpm/lpm) and operating air pressure (psi/MPa/bar):**

1. Locate fluid flow rate along bottom of chart.
2. Follow vertical line up to intersection with selected fluid outlet pressure curve.
3. Follow left to scale to read fluid outlet pressure.

# VERDERAIR VA 15 and VA 20 Performance Charts

## Air Consumption

**Test Conditions:** Pump tested in water with inlet submerged.

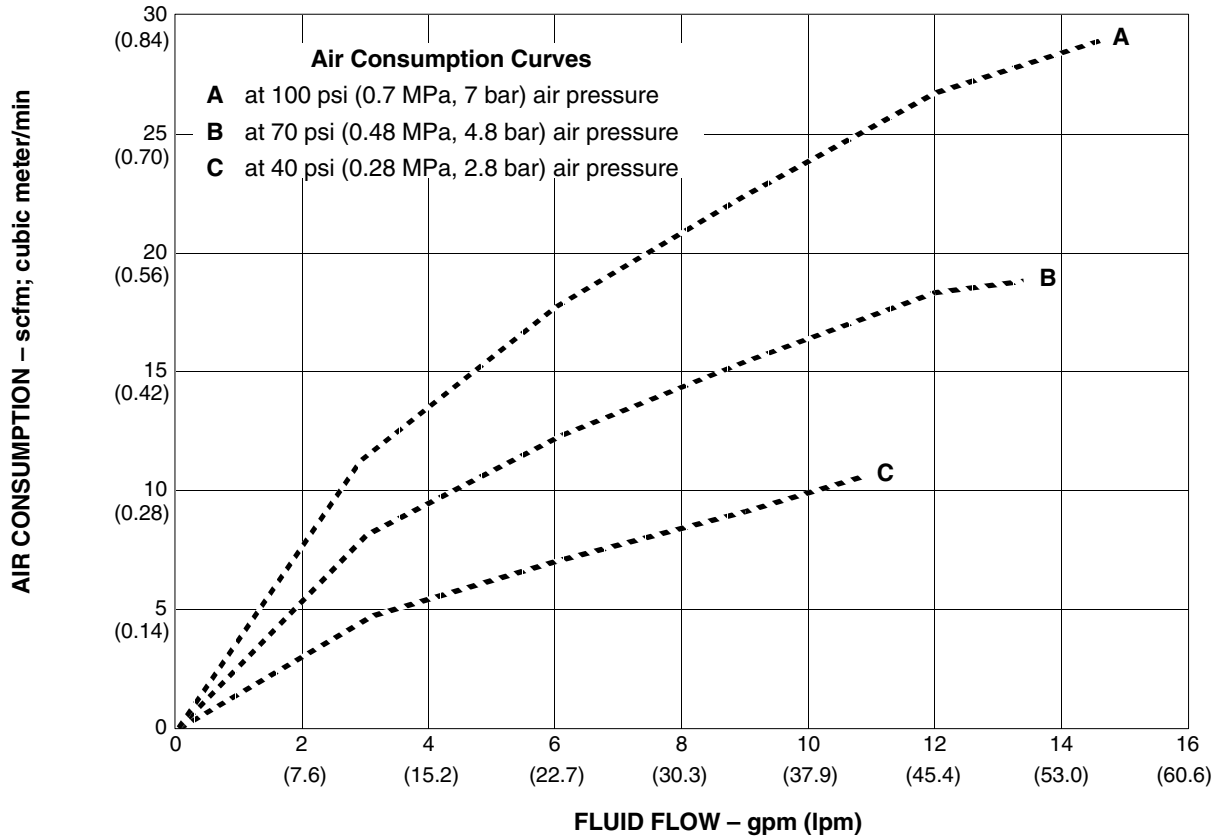

**To find Pump Air Consumption** (scfm or m<sup>3</sup>/min) at a specific fluid flow (gpm/lpm) and air pressure (psi/MPa/bar):

1. Locate fluid flow rate along bottom of chart.
2. Read vertical line up to intersection with selected air consumption curve.
3. Follow left to scale to read air consumption.

# Customer Services/Guarantee

## CUSTOMER SERVICES

If you require spare parts, please contact your local distributor, providing the following details:

- Pump Model
- Type
- Serial Number, and
- Date of First Order.

## GUARANTEE

All VERDER pumps are warranted to the original user against defects in workmanship or materials under normal use (rental use excluded) for two years after purchase date. This warranty does not cover failure of parts or components due to normal wear, damage or failure which in the judgement of VERDER arises from misuse.

Parts determined by VERDER to be defective in material or workmanship will be repaired or replaced.

## LIMITATION OF LIABILITY

To the extent allowable under applicable law, VERDER's liability for consequential damages is expressly disclaimed. VERDER's liability in all events is limited and shall not exceed the purchase price.

## WARRANTY DISCLAIMER

VERDER has made an effort to illustrate and describe the products in the enclosed brochure accurately; however, such illustrations and descriptions are for the sole purpose of identification and do not express or imply a warranty that the products are merchantable, or fit for a particular purpose, or that the products will necessarily conform to the illustration or descriptions.

## PRODUCT SUITABILITY

Many regions, states and localities have codes and regulations governing the sale, construction, installation and/or use of products for certain purposes, which may vary from those in neighbouring areas. While VERDER attempts to assure that its products comply with such codes, it cannot guarantee compliance, and cannot be responsible for how the product is installed or used. Before purchasing and using a product, please review the product application as well as the national and local codes and regulations, and be sure that product, installation, and use complies with them.

**VERDER**

# EC-DECLARATION OF CONFORMITY

EG-VERKLARING VAN OVEREENSTEMMING, DÉCLARATION DE CONFORMITÉ CE, EG-KONFORMITÄTSEKTLÄRUNG, DICHIARAZIONE DI CONFORMITÀ CE, EF-OVERENSSTEMMELSESEKTLÆRING, ΕΚ-ΔΗΛΩΣΗ ΣΥΜΜΟΡΦΩΣΗΣ, DECLARAÇÃO DE CONFORMIDADE – CE, DECLARACIÓN DE CONFORMIDAD DE LA CE, EY-VAATIMUSTENMUKAISUUSVAKUUTUS, EG-DEKLARATION OM ÖVERENSSTÄMMELSE, ES PROHLÁŠENÍ O SHODĚ, EÜ VASTAVUSDEKLARATSIOON, EC MEGFIEIÉLŐSÉGI NYILATKOZAT, EK ATBILSTÍBAS DEKLARACIJA, ES ATITIKTIES DEKLARACIJA, DEKLARACJA ZGODNOŚCI UE, DIKJARAZZJONI-KE TA' KONFORMITA', IZJAVA ES O SKLADNOSTI, ES - VYHLÁSENIE O ZHODE, EO-ΔΕΚΛΑΡΑCΙΑ ΖΑ CΒΜΕCΤΙΜΟCΤ, DEIMHNIÚ COMHRÉIREACHTA CE, CE-DECLARAȚIE DE CONFORMITATE

## Model

**VERDERAIR VA 15 and VA 20**

Modèle, Modell, Modello, Μοντέλο,  
Modelo, Malli, Mudel, Modelis, Mudell, Модел, Samhail

## Part

Bestelnr., Type, Teil, Codice, Del, Μέρος, Peça,  
Referencia, Osa, Součást, Részegység, Daja,  
Dalis, Część, Taqsima, Čast, Част, Páirt, Parte

810.0383–810.0418, 810.6758–810.6766, 810.6771, 810.6815–810.6847,  
810.6852–810.6855, 810.6881–810.6890, 810.6939–810.6971, 810.7004

## Complies With The EC Directives:

Voldoet aan de EG-richtlijnen, Conforme aux directives CE, Entspricht den EG-Richtlinien, Conforme alle direttive CE, Overholder EF-direktiverne, Σύμφωνα με τις Οδηγίες της ΕΚ, Em conformidade com as Directivas CE, Cumple las directivas de la CE, Täyttää EY-direktiivien vaatimukset, Uppfyller EG-direktiven, Shoda se směrnicemi ES, Vastab EÜ direktiividele, Kielégíti az EK irányelvek követelményeit, Atbilst EK direktīvām, Atitinka šias ES direktyvas, Zgodność z Dyrektywami UE, Konformi mad-Direttivi tal-KE, V skladu z direktivami ES, Je v súlade so smernicami ES, Съвместимост с Директиви на ЕО, Tá ag teacht le Treoracha an CE, Respectă directivele CE

2006/42/EC Machinery Directive94/9/EC ATEX Directive (EX II 2 GD c IIC T4) – Tech File stored with NB 0359

## Standards Used:

Gebruikte maatstaven, Normes respectées, Verwendete Normen, Norme applicate, Anvendte standarder, Πρότυπα που χρησιμοποιήθηκαν, Normas utilizadas, Normas aplicadas, Sovellettavat standardit, Tillämpade standarder, Použité normy, Rakendatud standardid, Alkalmazott szabványok, Izmantotie standarti, Taikyti standartai, Užyte normy, Standards Užati, Uporabljeni standardi, Použité normy, Използвани стандарти, Cíghdeáin arna n-úsáid, Standarde utilizate

EN 1127-1

EN 13463-1

ISO 12100

ISO 9614-1

## Notified Body for Directive

Aangemelde instantie voor richtlijn, Organisme notifié pour la directive, Benannte Stelle für diese Richtlinie, Ente certificatore della direttiva, Bemyndiget organ for direktiv, Διακοινωμένο όργανο Οδηγίας, Organismo notificado relativamente à directiva, Organismo notificado de la directiva, Direktiivin mukaisesti ilmoitettu tarkastuslaitos, Anmält organ för direktivet, Úředně oznámený orgán pro směrnici, Teavitatud asutus (direktiivi järgi), Az irányelvekkel kapcsolatban értesített testület, Piilvarotā iestāde saskaņā ar direktīvu, Apie direktīvā Informuota institūcija, Ciało powiadomione dla Dyrektywy, Korp avzat bid-Direttiva, Priglašeni organ za direktivo, Notifikovaný orgán pre smernicu, Нотифициран орган за Директива, Comhlacht ar tugadh fógra dó, Organism notificat în conformitate cu directiva

## Approved By:

Goedgekeurd door, Approuvé par, Genehmigt von, Approvato da, Godkendt af, Έγκριση από, Aprobado por, Aprobado por, Hyväksynyt, Intygas av, Schwáilil, Kinnitanud, Jóváhagyta, Apstiprināts, Patvirtino, Zatwierdzone przez, Approvat minn, Odobril, Schwálené, Одобрено от, Faofa ag, Aprobat de



Frank Meersman  
Director

29 December 2009

VERDER NV  
Kontichsesteenweg 17  
B-2630 Aartselaar  
BELGIUM

819.5963

**VERDER**

# EC-DECLARATION OF CONFORMITY

EG-VERKLARING VAN OVEREENSTEMMING, DÉCLARATION DE CONFORMITÉ CE, EG-KONFORMITÄTSEKTLÄRUNG, DICHIARAZIONE DI CONFORMITÀ CE, EF-OVERENSSTEMMELSESEKTLÆRING, ΕΚ-ΔΗΛΩΣΗ ΣΥΜΜΟΡΦΩΣΗΣ, DECLARAÇÃO DE CONFORMIDADE - CE, DECLARACIÓN DE CONFORMIDAD DE LA CE, EY-VAATIMUSTENMUKAISUUSVAKUUTUS, EG-DEKLARATION OM ÖVERENSSTÄMMELSE, ES PROHLÁŠENÍ O SHODĚ, EÜ VASTAVUSDEKLARATSIOON, EC MEGFIEIÉLŐSÉGI NYILATKOZAT, EK ATBILSTÍBAS DEKLARÁCIJA, ES ATITIKTIES DEKLARACIJA, DEKLARACIJA ZGODNOSTI UE, DIKJARAZZJONI-KE TA' KONFORMITA', IZJAVA ES O SKLADNOSTI, ES - VYHLÁSENIE O ZHODE, EO-DEKLARACIJA ZA CЪBMECTИMOC, DEIMHNIÚ COMHREIREACHTA CE, CE-DECLARAȚIE DE CONFORMITATE

## Model

**VERDERAIR VA 15**

Modèle, Modell, Modello, Μοντέλο,  
Modelo, Malli, Mudel, Modelis, Mudell, Модел, Samhail

## Part

810.6767–810.6770, 810.6772–810.6787, 810.6848–810.6850,  
810.6891–810.6894, 810.6896–810.6909, 810.6974, 810.7008,  
810.7071

Bestelnr., Type, Teil, Codice, Del, Μέρος, Peça,  
Referencia, Osa, Součást, Részegység, Daja,  
Dalis, Część, Taqsim, Čast, Част, Páirt, Parte

## Complies With The EC Directives:

Voldoet aan de EG-richtlijnen, Conforme aux directives CE, Entspricht den EG-Richtlinien, Conforme alle direttive CE, Overholder EF-direktiverne, Σύμφωνα με τις Οδηγίες της ΕΚ, Em conformidade com as Directivas CE, Cumple las directivas de la CE, Täyttää EY-direktiivien vaatimukset, Uppfyller EG-direktiven, Shoda se směrnicemi ES, Vastab EÜ direktiividele, Kielégíti az EK irányelvek követelményeit, Atbilst EK direktīvām, Atitinka šias ES direktyvas, Zgodność z Dyrektywami UE, Konformi mad-Direttivi tal-KE, V skladu z direktivami ES, Je v súlade so smernicami ES, Съвместимост с Директиви на ЕО, Tá ag teacht le Treoracha an CE, Respectă directivele CE

2006/42/EC Machinery Directive

## Standards Used:

Gebruikte maatstaven, Normes respectées, Verwendete Normen, Norme applicate, Anvendte standarder, Πρότυπα που χρησιμοποιήθηκαν, Normas utilizadas, Normas aplicadas, Sovellettavat standardit, Tillämpade standarder, Použité normy, Rakendatud standardid, Alkalmazott szabványok, Izmantotie standarti, Taikyti standartai, Užyte normy, Standards Užati, Uporabljeni standardi, Použité normy, Използвани стандарти, Caidheáin arna n-úsáid, Standarde utilizate

ISO 12100

ISO 9614-1

## Notified Body for Directive

Aangemelde instantie voor richtlijn, Organisme notifié pour la directive, Benannte Stelle für diese Richtlinie, Ente certificatore della direttiva, Bemyndiget organ for direktiv, Διακοινωμένο όργανο Οδηγίας, Organismo notificado relativamente à directiva, Organismo notificado de la directiva, Direktiivin mukaisesti ilmoitettu tarkastuslaitos, Anmält organ för direktivet, Úředně oznámený orgán pro směrnici, Teavitatud asutus (direktiivi järgi), Az irányelvekkel kapcsolatban értesített testület, Piilvarotā iestāde saskaņā ar direktīvu, Apie direktīvą Informuota institucija, Ciało powiadomione dla Dyrektywy, Korp avzat bid-Direttiva, Priglašeni organ za direktivo, Notifikovaný orgán pre smernicu, Нотифициран орган за Директива, Comhlacht ar tugadh fógra dó, Organism notificat în conformitate cu directiva

## Approved By:

Goedgekeurd door, Approuvé par, Genehmigt von, Approvato da, Godkendt af, Έγκριση από, Aprobado por, Aprobado por, Hyväksynyt, Intygas av, Schwáilil, Kinnitanud, Jóváhagyta, Apstiprināts, Patvirtino, Zatwierdzone przez, Approvat minn, Odobril, Schwálené, Одобрено от, Faofa ag, Aprobat de



Frank Meersman  
Director

29 December 2009

VERDER NV  
Kontichsesteenweg 17  
B-2630 Aartselaar  
BELGIUM

819.5963

**Austria**

Verder Austria  
 Eitnergasse 21/Top 8  
 A-1230 Wien  
 AUSTRIA  
 Tel: +43 1 86 51 074 0  
 Fax: +43 1 86 51 076  
 e-mail: office@verder.at

**Belgium**

Verder nv  
 Kontichsesteenweg 17  
 B-2630 Aartselaar  
 BELGIUM  
 Tel: +32 3 877 11 12  
 Fax: +32 3 877 05 75  
 e-mail: info@verder.be

**China**

Verder Retsch Shanghai Trading  
 Room 301, Tower 1  
 Fuhai Commercial Garden no 289  
 Bisheng Road, Zhangjiang  
 Shanghai 201204  
 CHINA  
 Tel: +86 (0)21 33 93 29 50 / 33 93 29 51  
 Fax: +86 (0)21 33 93 29 55  
 e-mail: info@verder.cn

**Czech Republic**

Verder s.r.o.  
 Vodnanská 651/6 (vchod Chlu-  
 mecka 15)  
 198 00 Praha 9–Kyje  
 CZECH REPUBLIC  
 Tel: +420 261 225 386–7  
 Web: <http://www.verder.cz>  
 e-mail: info@verder.cz

**Denmark**

Verder A/S  
 H.J. Holstvej 26  
 DK 2610 Rodovre  
 DENMARK  
 Tel: +45 3636 4600  
 e-mail: info@verder.dk

**France**

Verder France  
 Parc des Bellevues  
 Rue du Gros Chêne  
 F-95610 Eragny sur Oise  
 FRANCE  
 Tel: +33 134 64 31 11  
 Fax: +33 134 64 44 50  
 e-mail: verder-info@verder.fr

**Germany**

Verder Deutschland GmbH  
 Retsch–Allee 1–5  
 42781 Haan  
 GERMANY  
 Tel: 02104/2333–200  
 Fax: 02104/2333–299  
 e-mail: info@verder.de

**Hungary**

Verder Hungary Kft  
 Budafoke ut 187 – 189  
 HU–1117 Budapest  
 HUNGARY  
 Tel: 0036 1 3651140  
 Fax: 0036 1 3725232  
 e-mail: info@verder.hu

**The Netherlands**

Verder BV  
 Leningradweg 5  
 NL 9723 TP Groningen  
 THE NETHERLANDS  
 Tel: +31 50 549 59 00  
 Fax: +31 50 549 59 01  
 e-mail: info@verder.nl

**Poland**

Verder Polska  
 ul.Ligonia 8/1  
 PL-40 036 Katowice  
 POLAND  
 Tel: +48 32 78 15 032  
 Fax: +48 32 78 15 034  
 e-mail: verder@verder.pl

**Romania**

Verder România  
 Drumul Balta Doamnei no  
 57–61  
 Sector 3  
 CP 72–117  
 032624 Bucuresti  
 ROMANIA  
 Tel: +40 21 335 45 92  
 Fax: +40 21 337 33 92  
 e-mail: office@verder.ro

**Slovak Republic**

Verder Slovakia s.r.o.  
 Silacska 1  
 SK–831 02 Bratislava  
 SLOVAK REPUBLIC  
 Tel: +421 2 4463 07 88  
 Fax: +421 2 4445 65 78  
 e-mail: info@verder.sk

**South Africa**

Verder SA  
 197 Flaming Rock Avenue  
 Northlands Business Park  
 Newmarket Street  
 ZA Northriding  
 SOUTH AFRICA  
 Tel: +27 11 704 7500  
 Fax: +27 11 704 7515  
 e-mail: info@verder.co.za

**Switzerland**

Verder AG  
 Auf dem Wolf 19  
 CH–4052 Basel  
 SWITZERLAND  
 Tel: +41 (0)61 373 7373  
 e-mail: info@verder.ch

**United Kingdom**

Verder Ltd.  
 Whitehouse Street  
 GB–Hunslet, Leeds LS10 1AD  
 UNITED KINGDOM  
 Tel: +44 113 222 0250  
 Fax: +44 113 246 5649  
 e-mail: info@verder.co.uk

**United States of America**

Verder Inc.  
 110 Gateway Drive  
 Macon, GA 31210  
 USA  
 Toll Free: 1 877 7 VERDER  
 Tel: +1 478 471 7327  
 Fax: +1 478 476 9867  
 e-mail: info@verder.com