

CARBON STEEL GATE VALVE FLANGED CLASS 150 PN20



Size : DN 50 to DN 400 (NPS 2" to 16")
Ends : Flanges R.F. CLASS 150 (PN20)
Min Temperature : - 29°C
Max Temperature : + 425°C
Max Pressure : 20 Bars
Specifications : Rising, non-rotating stem
Bolted bonnet and gland pack
Full bore

Materials : Carbon steel

CARBON STEEL GATE VALVE FLANGED CLASS 150 PN20

SPECIFICATIONS :

- Full bore
- Rising, non-rotating stem
- Fixed non rising handwheel
- Flexible one piece wedge
- Flanges R.F. Class 150 (PN20)
- Carbon steel body
- Bolted bonnet and gland pack
- ½ stellite (Trim 8 , seat with stellite)
- Grey painting RAL 7001 color, 60 µm thickness

USE :

- Water distribution, gas oil, steam, petrochemical, petroleum industry, gas
- Min and max Temperature Ts : - 29°C to + 425°C
- Max Pressure Ps : 20 bars
- **Do not use with scraper**
- **Tighten the gland packing in service**

FLOW COEFFICIENT Kvs :

DN (mm)	50	80	100	150	200	250	300	350	400
NPS (")	2"	3"	4"	6"	8"	10"	12"	14"	16"
Kvs	60	94	162.8	366.3	651.1	1017.4	1456	1837	2438

PRESSURE / TEMPERATURE RELATION :

(According to AMSE B16-34 for A216 WCB)

Pressure (Bar)	19.6	19.6	17.9	15.8	13.8	11.7	9.6	8.6	7.6	6.5	5.5
Temperature (°C)	-29	38	93	149	204	260	316	343	371	399	425

PRESSURE / TEMPERATURE GRAPH :

Pressure

(Bar)

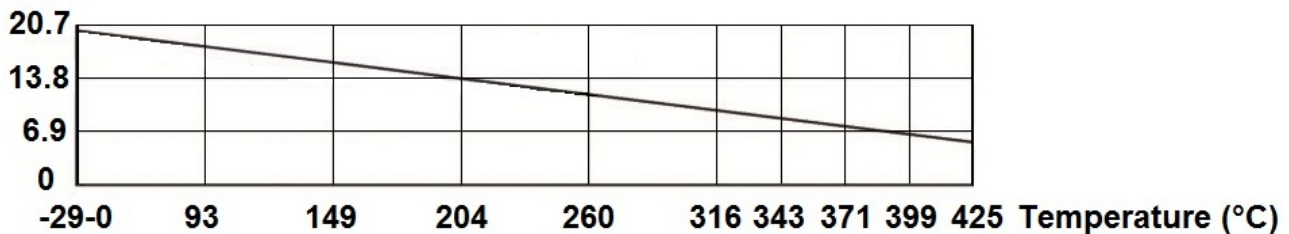

RANGE :

- Carbon steel gate valve with flanges R.F. Class 150 (PN20) **Ref. 143** From DN 50 to DN 350 (from NPS 2" to 14")
- Carbon steel gate valve with flanges R.F. Class 150 (PN20) with gearbox **Ref. 143** DN 400 (from NPS 16")

CARBON STEEL GATE VALVE FLANGED CLASS 150 PN20

MATERIALS DN50-350 (NPS 2" to 14") :

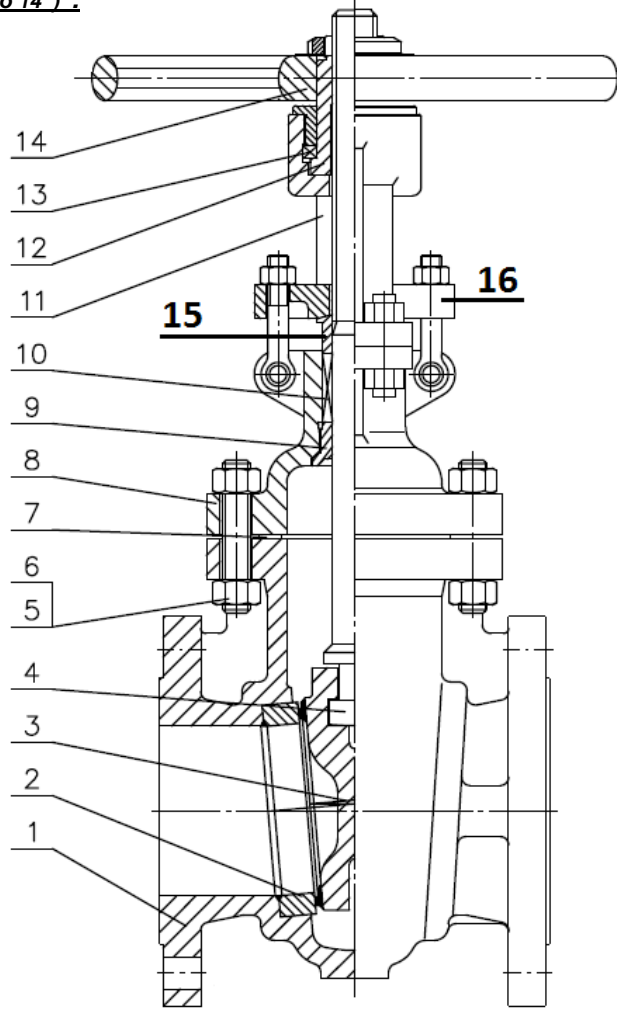

(* : included in gaskets kit)

Item	Designation	Materials
1	Body	ASTM A216 WCB
2	Seat	ASTM A105 + Stellite Gr.6
3	Wedge	ASTM A216 WCB + 13Cr
4	Stem	ASTM A182 F6a
5	Stud bolt	ASTM A193 Gr B7
6	Nut	ASTM A194 Gr 2H
7*	Bonnet gasket	SS 304 + graphite
8	Bonnet	ASTM A216 WCB
9	Back seat bushing	ASTM A276-420
10*	Packing	Flexible graphite
11	Yoke	ASTM A216 WCB
12	Stem nut	Aluminium + Bronze
13	Ring	E51100
14	Handwheel	Cast iron
15	Packing gland	ASTM A276-420
16	Gland flange	ASTM A216 WCB

CARBON STEEL GATE VALVE FLANGED CLASS 150 PN20

MATERIALS DN400 (NPS 16") :

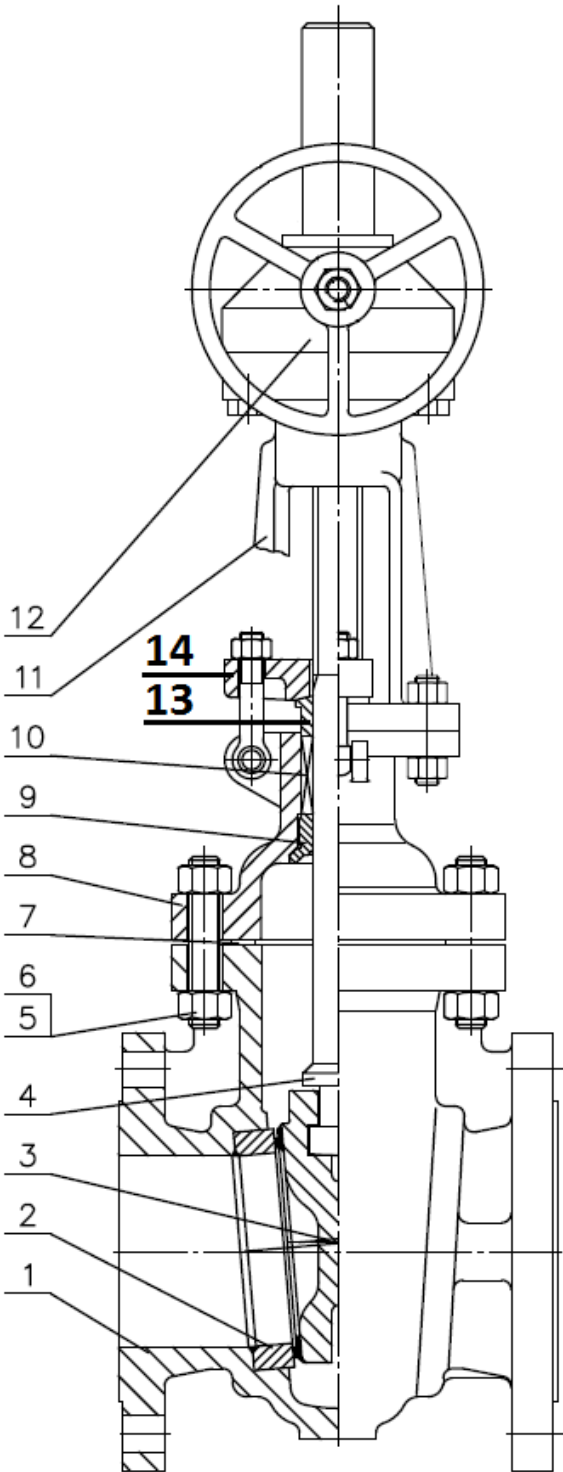

Item	Designation	Materials
1	Body	ASTM A216 WCB
2	Seat	ASTM A105 + Stellite Gr.6
3	Wedge	ASTM A216 WCB + 13Cr
4	Stem	ASTM A182 F6a
5	Stud Bolt	ASTM A193 Gr B7
6	Nut	ASTM A194 Gr 2H
7*	Bonnet gasket	SS 304 + graphite
8	Bonnet	ASTM A216 WCB
9	Back seat bushing	ASTM A276-420
10*	Packing	Flexible graphite
11	Yoke	ASTM A216 WCB
12	Gearbox	-
13	Packing gland	ASTM A276-420
14	Gland flange	ASTM A216 WCB

(* : included in gaskets kit)

CARBON STEEL GATE VALVE FLANGED CLASS 150 PN20

SIZE DN 50-350 (NPS 2"-14") (in mm) :

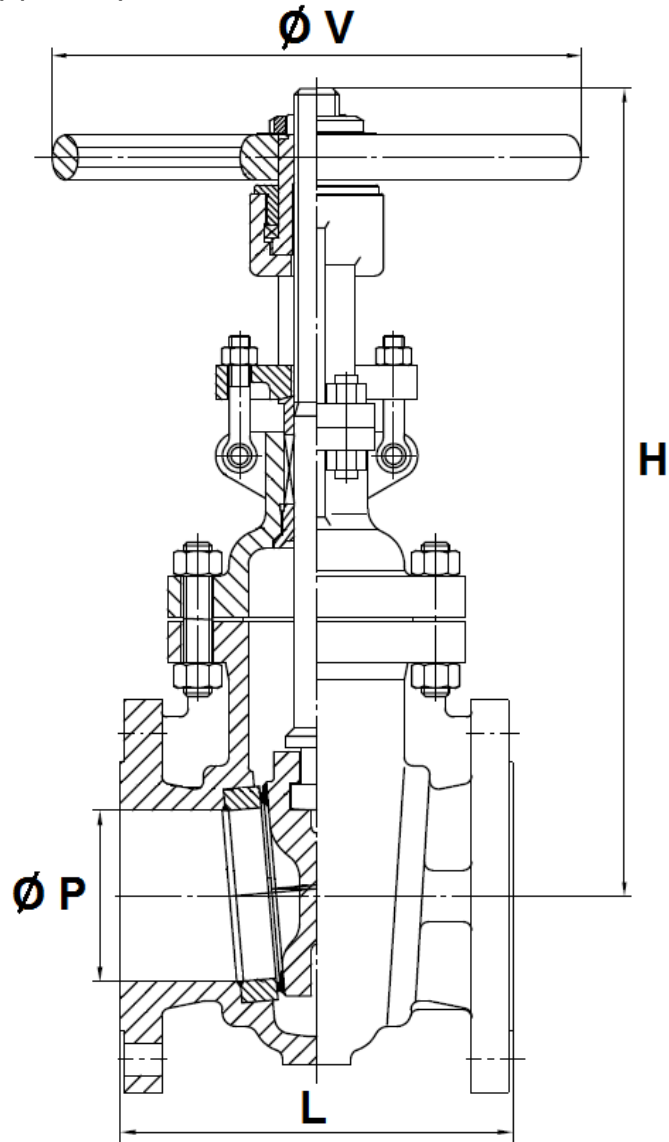

Ref.	DN (mm)	50	80	100	150	200	250	300	350
	NPS (")	2"	3"	4"	6"	8"	10"	12"	14"
143	Ø P	51	76	102	152	203	254	305	334
	L	178	203	229	267	292	330	356	381
	H (opened)	410	500	581	745	971	1160	1376	1508
	H (closed)	355	421	479	593	768	905	1071	1185
	Ø V	200	240	300	350	400	400	500	600
	Weight (Kg)	18	31	47	79	130	185	283	330

CARBON STEEL GATE VALVE FLANGED CLASS 150 PN20

SIZE DN 400 (NPS 16") (in mm) :

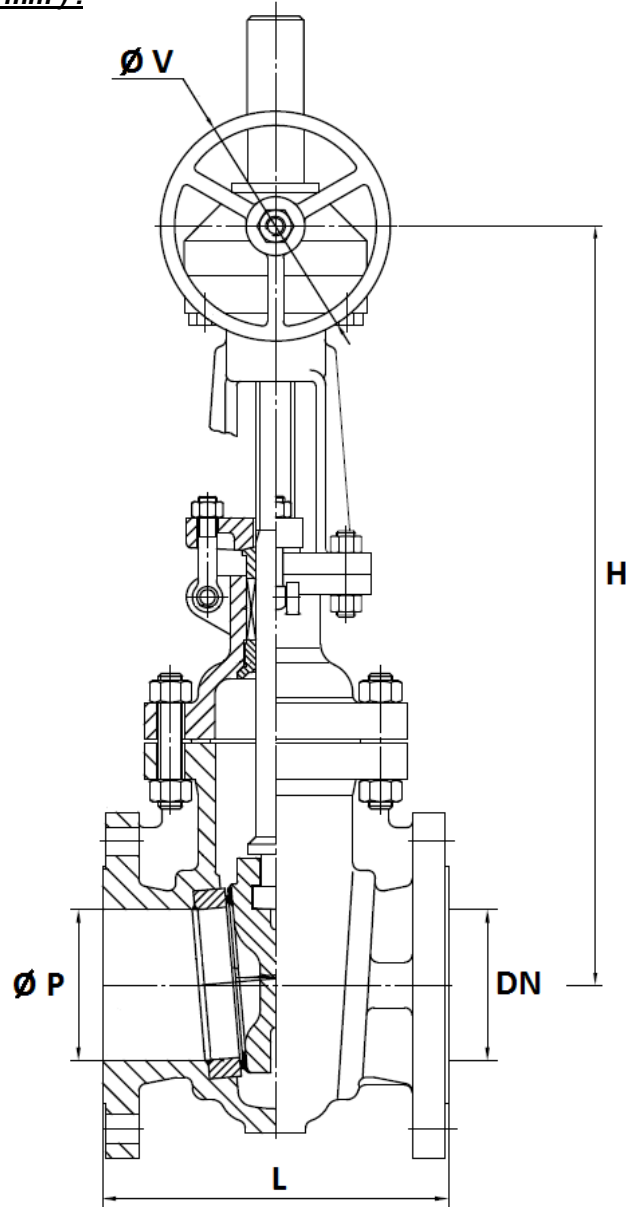

Ref.	DN (mm)	400
	NPS (")	16"
143	Ø P	385
	L	406
	H	1335
	Ø V	460
	Weight (in Kg)	424

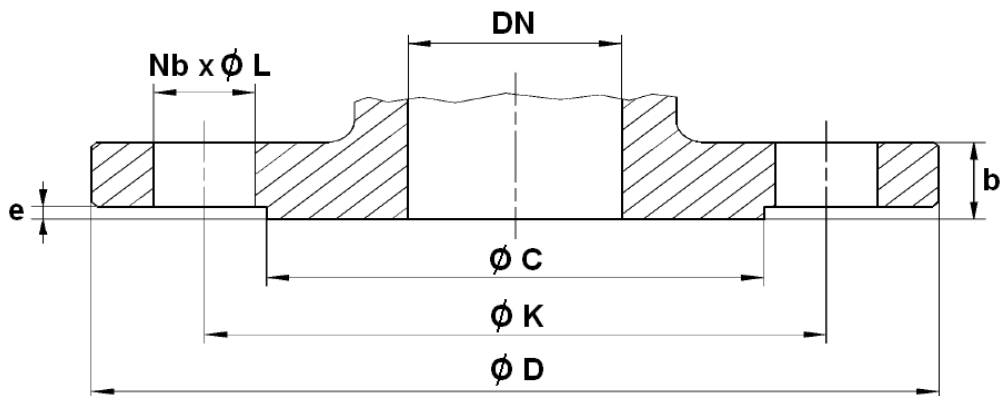
CARBON STEEL GATE VALVE FLANGED CLASS 150 PN20
FLANGES SIZE (in mm):

DN (mm)	50	80	100	150	200	250	300	350	400
NPS (")	2"	3"	4"	6"	8"	10"	12"	14"	16"
Ø C	92.1	127	157.2	215.9	269.9	323.8	381	412.8	469.9
Ø D	150	190	230	280	345	405	485	535	595
Ø K	120.7	152.4	190.5	241.3	298.5	362	431.8	476.3	539.8
Nb x Ø L	4 x 19	4 x 19	8 x 19	8 x 22	8 x 22	12 x 26	12 x 26	12 x 29	16 x 29
b	16.3	19.5	24.3	25.9	29	30.6	32.2	35.4	37
e	2	2	2	2	2	2	2	2	2

CARBON STEEL GATE VALVE FLANGED CLASS 150 PN20
TORQUE VALUE (in Nm without safety coefficient) :

DN	50	80	100	150	200	250	300	350	400
NPS (")	2"	3"	4"	6"	8"	10"	12"	14"	16"
Torque (Nm)	37	85	107	180	265	410	540	730	1055

NUMBER OF CYCLES TO CLOSE OR OPEN THE VALVE :

DN	50	80	100	150	200	250	300	350	400
NPS (")	2"	3"	4"	6"	8"	10"	12"	14"	16"
Number of cycles	15	18	23	33	38	45	55	60	52

STANDARDS :

- Fabrication according to ISO 9001 : 2008
- DIRECTIVE 97/23/CE : CE N° 0036
Risk category III Module H
- Designing according to API 600
- Pressure Tests according to API 598, table 6
- Length according to ASME B16.10, table 1 A8 series
- Flanges R.F. according to ASME B16.05
- ATEX Group II Category 2 G/2D Zone 1 & 21 Zone 2 & 22 (optional marking)
- Approval certificate Russian **GOST-R**
- Materials according to NACE MR 01-75 **on request**

ADVICE : Our opinion and our advice are not guaranteed and SFERACO shall not be liable for the consequences of damages. The customer must check the right choice of the products with the real service conditions.

CARBON STEEL GATE VALVE FLANGED CLASS 150 PN20

INSTALLATION INSTRUCTIONS

GENERAL GUIDELINES :

- Ensure that the valves to be used are appropriate for the conditions of the installation (type of fluid, pressure and temperature).
- Be sure to have enough valves to be able to isolate the sections of piping as well as the appropriate equipment for maintenance and repair.
- Ensure that the valves to be installed are of correct strength to be able to support the capacity of their usage.
- **Installation of all circuits should ensure that their function can be automatically tested on a regular basis (at least two times a year).**

INSTALLATION INSTRUCTIONS :

- **Before installing the valves, clean and remove any objects from the pipes** (in particular bits of sealing and metal) which could obstruct and block the valves.
- **Ensure that both connecting pipes either side of the valve (upstream and downstream) are aligned (if they're not, the valves may not work correctly).**
- **Make sure that the two sections of the pipe (upstream and downstream) match, the valve unit will not absorb any gaps. Any distortions in the pipes may affect the tightness of the connection, the working of the valve and can even cause a rupture.** To be sure, place the kit in position to ensure the assembling will work.
- **If sections of piping do not have their final support in place, they should be temporarily fixed. This is to avoid unnecessary strain on the valve.**
- Tighten the bolts in cross.
- It's recommended to operate the valve (open and close) 1 to 2 times per year
- Keep greased the stem so that the valve remains easy to open or close.