

TECHNISCHE ÄNDERUNGEN VORBEHALTEN · NACHDRUCK UND KOPIEN NUR MIT UNSEREM EINVERSTÄNDNIS · Specifications subject to change without notice · Copyright ELAFLEX

GRUPPE 2 Section	Gewicht Weight Approx. ≈ kg	FÜR SCHLAUCHGRÖSSE For Hose Size			GEWINDE ART + GRÖSSE Thread Type + Size G	BESTELL- NUMMER Part Number Type
		ID mm	ID in.	OD mm		
Type V	0,11	13	1/2"	22	R 1/2" (BSP)	V 13 - 1/2"
	0,12				1/2" NPT (API)	V 13 - 1/2" NPT
	0,15	16	5/8"	26	R 3/4" (BSP)	V 16 - 3/4"
	0,16				R 3/4" ^{DIN 2999} (BSPT)	V 16 - 3/4" BSPT
	0,16				3/4" NPT (API)	V 16 - 3/4" NPT
	0,17				R 1" (BSP)	V 16 - 1"
	0,17	19	3/4"	27	R 1" ^{DIN 2999} (BSPT)	V 16 - 1" BSPT
	0,14				R 3/4" (BSP)	V 19 - 3/4" LC
	0,17				R 1" (BSP)	V 19 - 1" LC
	0,17	19	3/4"	31	R 3/4" (BSP)	V 19 - 3/4"
	0,17				R 3/4" ^{DIN 2999} (BSPT)	V 19 - 3/4" BSPT
	0,17				3/4" NPT (API)	V 19 - 3/4" NPT
	0,20				R 1" (BSP)	V 19 - 1"
	0,20				R 1" ^{DIN 2999} (BSPT)	V 19 - 1" BSPT
	0,21	21	7/8"	31	R 1" (BSP)	V 21 - 1"
0,22	25	1"	34	R 1" (BSP)	V 25 - 1" LC	
0,23				1" NPT (API)	V 25 - 1" NPT LC	
0,24	25	1"	37	R 1" (BSP)	V 25 - 1"	
0,25				R 1" ^{DIN 2999} (BSPT)	V 25 - 1" BSPT	
0,25				1" NPT (API)	V 25 - 1" NPT	
0,25						
0,15	16	5/8"	26	R 3/4" (BSP)	V 16 - 3/4" cr	
0,16				R 3/4" ^{DIN 2999} (BSPT)	V 16 - 3/4" BSPT cr	
0,16				3/4" NPT (API)	V 16 - 3/4" NPT cr	
0,17				R 1" (BSP)	V 16 - 1" cr	
0,17				R 1" ^{DIN 2999} (BSPT)	V 16 - 1" BSPT cr	
0,17	19	3/4"	31	R 3/4" (BSP)	V 19 - 3/4" cr	
0,17				R 3/4" ^{DIN 2999} (BSPT)	V 19 - 3/4" BSPT cr	
0,17				3/4" NPT (API)	V 19 - 3/4" NPT cr	
0,20				R 1" (BSP)	V 19 - 1" cr	
0,21	21	7/8"	31	R 1" ^{DIN 2999} (BSPT)	V 19 - 1" BSPT cr	
0,21				R 1" (BSP)	V 21 - 1" cr	
0,24				R 1" (BSP)	V 25 - 1" cr	
0,25	25	1"	37	R 1" ^{DIN 2999} (BSPT)	V 25 - 1" BSPT cr	
0,25				1" NPT (API)	V 25 - 1" NPT cr	
0,11	13	1/2"	22	R 1/2" (BSP)	V 13 - 1/2" SS	
0,12				1/2" NPT (API)	V 13 - 1/2" NPT SS	
0,14	16	5/8"	26	R 5/8" (BSP)	V 16 - 5/8" SS	
0,15				R 3/4" (BSP)	V 16 - 3/4" SS	
0,16				3/4" NPT (API)	V 16 - 3/4" NPT SS	
0,17	19	3/4"	31	R 3/4" (BSP)	V 19 - 3/4" SS	
0,17				3/4" NPT (API)	V 19 - 3/4" NPT SS	
0,20				R 1" (BSP)	V 19 - 1" SS	
0,24				R 1" (BSP)	V 25 - 1" SS	
0,25	25	1"	37	1" NPT (API)	V 25 - 1" NPT SS	
0,27				R 1 1/4" (BSP)	V 25 - 1 1/4" NPT SS	
0,15	16	5/8"	26	R 3/4" (BSP)	V 16 - 3/4" NR	
0,16				R 3/4" (BSPT)	V 16 - 3/4" BSPT NR	
0,17				R 1" (BSP)	V 16 - 1" NR	
0,24	25	1"	37	R 1" (BSP)	V 25 - 1" NR	
0,15	16	5/8"	26	R 3/4" (BSP)	V 16 - 3/4" NR cr	
0,16				R 3/4" (BSPT)	V 16 - 3/4" BSPT NR cr	
0,17				R 1" (BSP)	V 16 - 1" NR cr	
0,24				R 1" (BSP)	V 25 - 1" NR cr	



Vaterverschraubungen mit Schraubhülsen - Einband, geeignet zur Selbstmontage. Entsprechen DIN EN 14424 und Bundeswehnorm VG 95951. Nenndruck bis 25 bar. - Chemische Beständigkeit siehe Seite 250.

Hose fittings (ferrule type) with male thread, suitable for self-assembly. Working pressure up to 25 bar. Meet EN 14424. Chemical resistance chart see page 250.

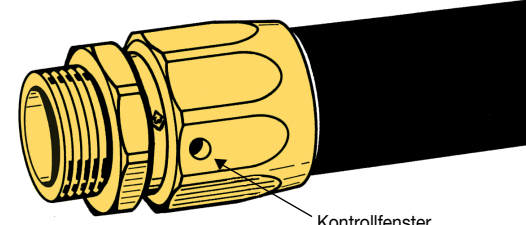

Kontrollfenster
control opening

Schlauchstutzen und Hülse: Pressmessing blank gebeizt

Type V
Hose tail and ferrule of hot stamped brass.

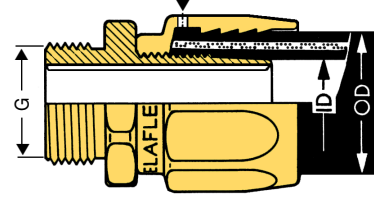

Schlauchstutzen und Hülse: Pressmessing blank verchromt

Type V - cr
Hose tail and ferrule of hot stamped brass, chrome plated

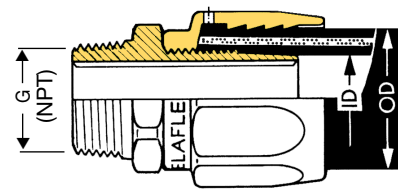
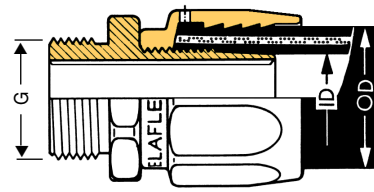

Schlauchstutzen aus 1.4571. Hülse aus Pressmessing blank verchromt

Type V - SS
Hose tail with male thread of stainless steel. Ferrule of hot stamped brass, chrome plated.

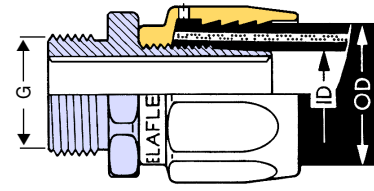

Werksmontierte Hülsen - Vaterverschraubungen, **nicht** demontierbar.

Schlauchstutzen und Hülse Pressmessing (cr: verchromt)

Type V - NR
Hose tail and ferrule hot stamped brass (cr: chrome plated).

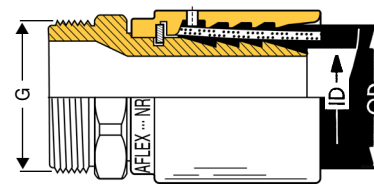

Factory assembled hose fittings (ferrule type), **non-reattachable**.

Montage von Schraubhülsen - Einbindungen • Assembly Instructions Ferrule Type

1

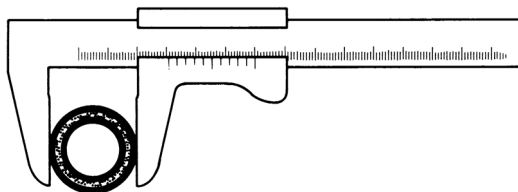

Als Voraussetzung für eine betriebssichere Montage muß der äußere Durchmesser des Schlauches dem umseitigen "OD" - Maß entsprechen. Maximale Toleranz $\pm 0,5$ mm

Before assembly please check whether the outer diameter of the hose conforms with the "OD" measure listed overleaf. Maximum tolerance for safe assembly $\pm 0,5$ mm

2

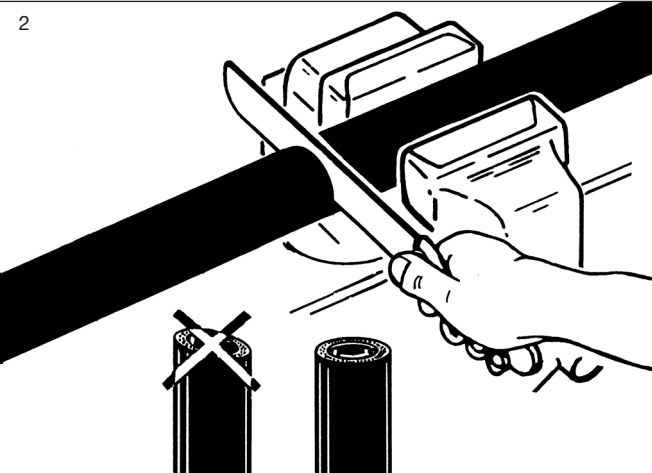

3

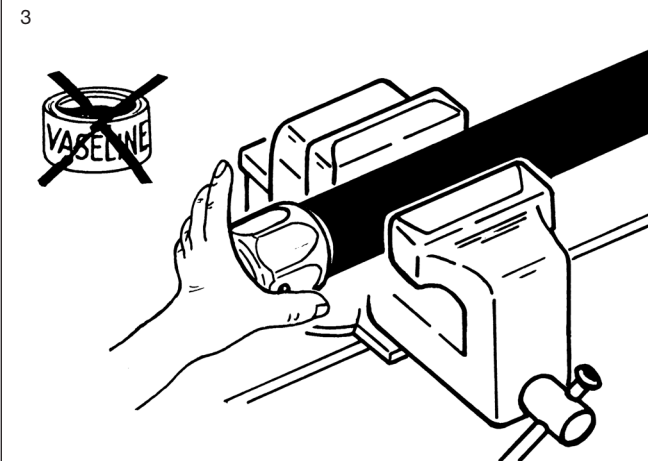

4

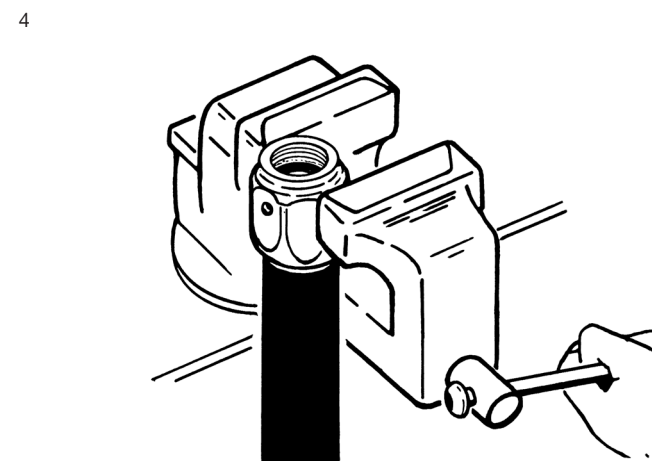

5

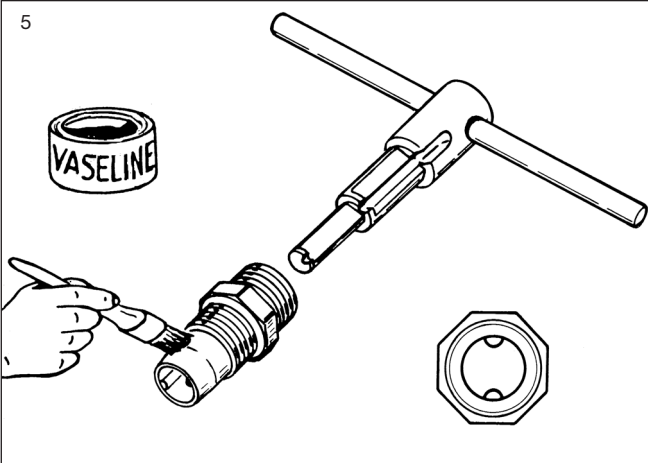

6

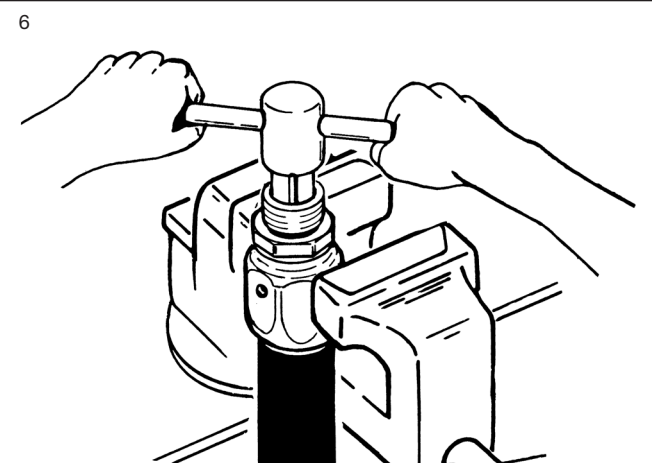

7

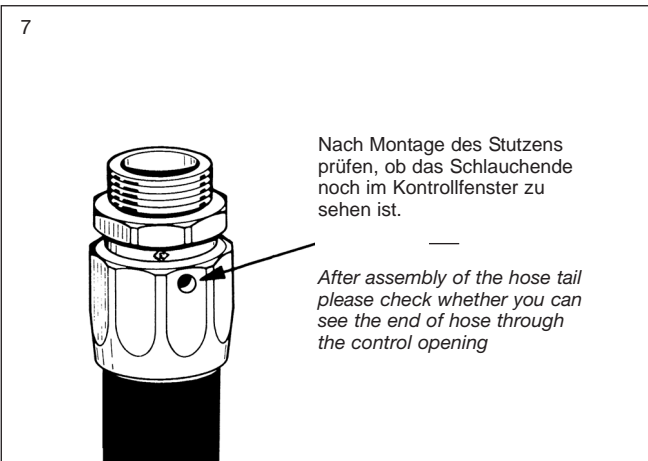

Nach Montage des Stutzens prüfen, ob das Schlauchende noch im Kontrollfenster zu sehen ist.

After assembly of the hose tail please check whether you can see the end of hose through the control opening

8

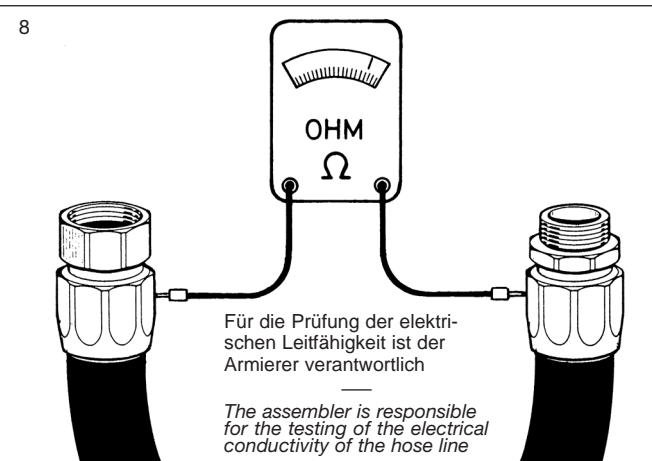

Für die Prüfung der elektrischen Leitfähigkeit ist der Armierer verantwortlich

The assembler is responsible for the testing of the electrical conductivity of the hose line