

Code ST06	Project A25-B	Release G	Title TECHNICAL DATASHEET
---------------------	-------------------------	---------------------	-------------------------------------

MAGNETIC TRANSDUCER MTS H

GENERAL FEATURES

- Small overall dimensions of the TRANSDUCER.
- MAGNETIC BAND MP500 (or MP500Z with positioned reference signals upon request) is composed of a magnetic strip, which is polarized at regular distances of 5+5 mm and supported by a stainless steel tape. Extremely easy to mount on the operating machine.

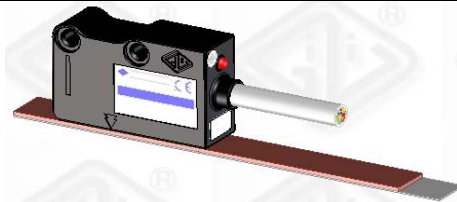

MECHANICAL AND ELECTRICAL FEATURES

MECHANICAL

- Die-cast transducer.
- Double fixing system transducer with M4 screw thread or with M3 through screws.
- Wide mounting tolerances.

ELECTRICAL

- Very flexible power cable.
- High stability of signals.
- For applications where max. speed exceeds 1 m/s, the use of a "special cable" is requested.

CABLE (2 meters standard length)

Minimum bending radius 60 mm

8 CORES Ø 5.3 mm

CONNECTIONS

LINE DRIVER

PUSH-PULL

GREEN	A	A
ORANGE	\bar{A}	
WHITE	B	B
SKY BLUE	\bar{B}	
BROWN	Z	Z
YELLOW	\bar{Z}	
RED	V +	V +
BLUE	V -	V -
SHIELD		

The sensor is normally supplied with a 2 m cable. It is possible to require longer cable, considering the following maximum available length.

$$L_{MAX} = 10 \text{ m (sensor cable);}$$

$$L_{MAX} = 100 \text{ m (2 m sensor cable + cable extension*)}$$

Code MTS H	
Reference signal	constant pitch every 5 mm (C) external (E) positioned on magnetic band (Z)
Pole pitch	5+5 mm
Resolution	100 - 50 - 25 - 10 - 5 μm
Accuracy**	$\pm 40 \mu\text{m}$
Repeatability	± 1 increment
Cable	8 cores
Output signals	LINE DRIVER / PUSH-PULL
Max. measuring frequency	300 kHz
Sensor - magnetic band distance	see drawings
Power supply	5 \div 28 Vdc \pm 5%
Current consump. without load	60 mA _{MAX}
Current consumption with load	140 mA _{MAX} (with 5 V and Zo = 120 Ω) 115 mA _{MAX} (with 12 V and Zo = 1.2 k Ω) 90 mA _{MAX} (with 28 V and Zo = 1.2 k Ω)
Phase displacement	90° \pm 5° electrical
Max. speed	6 m/s (MTS H5) / 12 m/s (MTS H10)
Vibration resistance	300 m/s ² [55 \div 2000 Hz]
Shock resistance	1000 m/s ² (11 ms)
Protection class	IP67 DIN 40050/IEC 529
Operating temperature	0° \div 50°C
Storage temperature	-20° \div 80°C
Relative humidity	100% (not condensed)
Weight of transducer	40 g
Electrical protections	inversion of power supply polarity and short-circuits on output port

* Cable extension with power supply conductor section of 0.5 mm².

** In order to obtain this accuracy value, it is necessary to respect the alignment tolerance values prescribed by Manufacturer. Better accuracy results can be obtained by reducing the gap between the sensor and the magnetic band.

ORDERING CODE

MODEL	PITCH	RESOLUTION	ZERO MARKER	POWER SUPPLY	OUTPUT	CABLE	CONNECTION
MTS	H	10	C	528V	L	M02/N	SC
MTS	H = 5+5mm	5 = 5 μm 10 = 10 μm 25 = 25 μm	C = constant pitch E = external Z = selected on magnetic band	528V = 5 \div 28V	L = LINE DRIVER	M01/N = 1m M02/N = 2m M10/N = 10m	SC = without connector C3 = C3 C4 = C4

Example  **MAGNETIC SENSOR MTS H10C 528VL M02/N SC**

Code ST06	Project A25-B	Release G	Title TECHNICAL DATASHEET
---------------------	-------------------------	---------------------	-------------------------------------

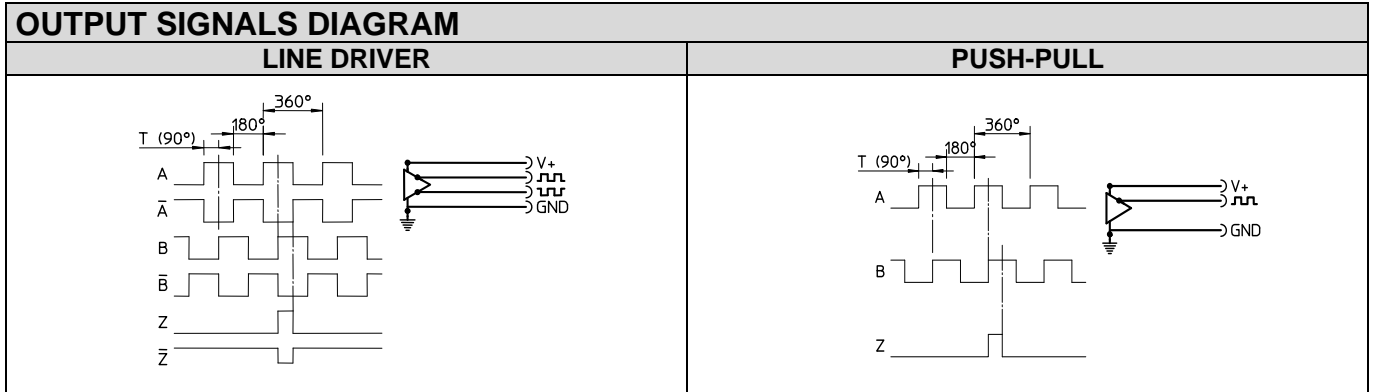

SENSOR DIMENSIONS

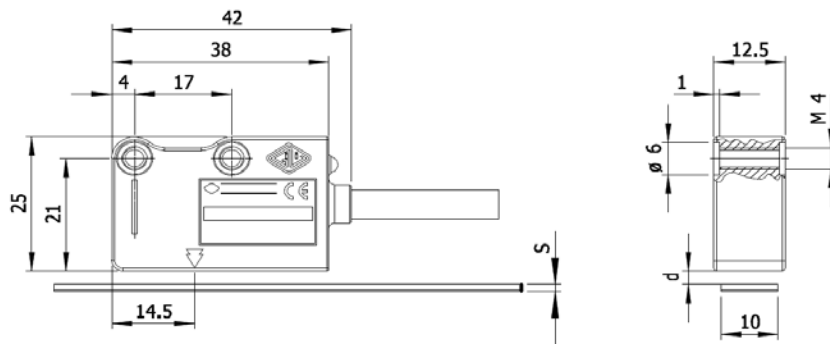

S(mm)	MP500Z	MP500Z+CV103	MP500Z+SP202
d(mm)	0.3+3.5	3.2 _{MAX}	2.7 _{MAX}

S(mm)	MP500	MP500+CV103	MP500+SP202
d(mm)	0.3+3.5	3.2 _{MAX}	2.7 _{MAX}

d → distance between sensor and top side of S

ALIGNMENT TOLERANCES SENSOR-STRIP

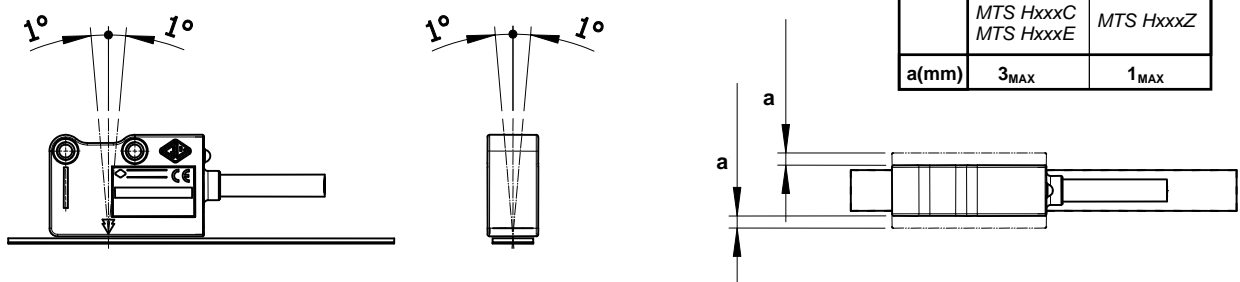

INSTALLATION AND HANDLING

RECOMMENDED MAGNETIC BAND FIXING 1. Remove grease from the surfaces by using alcohol and give a finishing touch by using a dry cloth. 2. Fix the magnetic band. 3. Fix the cover strip. After 48 hours the best adhesion will be obtained.	WHAT TO AVOID 1. All mechanical reworks (cutting, drilling, face milling etc.). 2. All modifications of the body of slider. 3. All mishandling. 4. Impacts and external stress. 5. Exposure to external magnetic fields.	
---	--	---